

PRICE \$2.00

HEATH COMPANY • BENTON HARBOR, MICHIGAN



# HEATHKIT® ASSEMBLY MANUAL



6-METER SSB TRANSCEIVER

MODEL SB-110A



# HEATH COMPANY

Phone 616-983-3961 • TWX-616-983-3897 • Benton Harbor, Michigan 49023

Dear Customer:

To serve you better, we have switched over to a computerized system of assigning part numbers to the components in Heath products. Because several thousand part numbers are involved, it will be a few months before we have the new part numbers printed in all Heath manuals and marked on the parts. As a result, some of the parts in your new Heath equipment may be marked with a part number that is slightly different from the part number listed in the Manual. If you order a part from Heath Company, be sure to use the part number printed in the manual, even though it may be slightly different from the number marked on the part.

Only those old part numbers that include one or more letters are affected. The following examples show how old part numbers that include letters are changed:

<u>OLD PART NO.</u>	<u>NEW PART NO.</u>
1L-4	1-4-12
5B-1	5-1-2
54X-11	54-11-24
85-145P417P293	85-145-4
100-M602	100-602
100-M596P360	100-596-1
204-M704	204-704
462-M132	462-132-1

Thank you,

HEATH COMPANY

Part No.  
4-1-67

597-394

Assembly and Operation

of the



# 6-METER SSB TRANSCEIVER

MODEL SB-110A

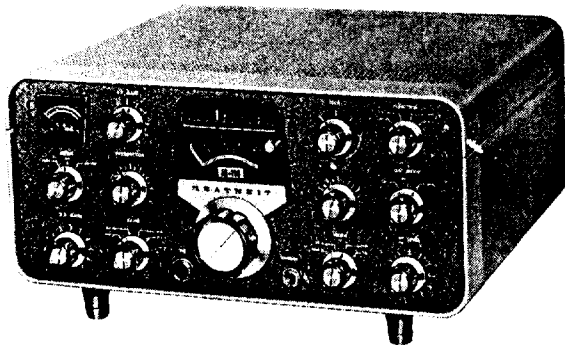

HEATH COMPANY BENTON HARBOR, MICHIGAN 49022

## TABLE OF CONTENTS

Introduction. . . . .	2
Step-By-Step Assembly. . . . .	3
Circuit Board Parts List. . . . .	3
Circuit Board Assembly. . . . .	5
Chassis Parts List. . . . .	18
Chassis Assembly. . . . .	24
Control Functions. . . . .	79
Preliminary Checks. . . . .	81
Power Supply Connections. . . . .	86
Initial Test. . . . .	88
Alignment. . . . .	89
Special Crystal Considerations. . . . .	95
Cabinet Installation. . . . .	97
Installation. . . . .	99
Operation. . . . .	105
In Case Of Difficulty. . . . .	110
Troubleshooting Chart. . . . .	111
Specifications. . . . .	121
Circuit Description. . . . .	127
Schematic. . . . (fold-out from page). . . . .	149
Replacement Parts Price List. . . . .	151

*See page 105 for details*

## INTRODUCTION

The Heathkit Model SB-110A 6-Meter Transceiver is a complete, self-contained transmitter and receiver. Heathkit DC and AC power supplies are available for use with the Transceiver to provide both mobile and fixed-station operation. The Transceiver is capable of SSB (single sideband with suppressed carrier) and CW (keyed continuous wave) operation. It may also be used as an exciter for a 6-meter linear amplifier.

Both VOX (voice-operated-transmit) and PTT (push-to-talk) operation are provided. An anti-VOX circuit prevents the received signal, at the speaker, from switching the transmitter on during VOX operation. The preassembled, prealigned linear master oscillator (LMO) and crystal-controlled heterodyne oscillators assure accurate, stable operation.

A large tuning knob, plus the smooth operation of the dial mechanism, provides convenient, backlash-free tuning. A built-in crystal calibrator allows the dial to be accurately calibrated at 100 kc intervals. Other features include: ALC (automatic level control), to prevent overdriving the final amplifiers; VOX operated CW operation; and an S meter that is switch-controlled in the transmit mode of operation to measure Plate Current, ALC voltage, and Relative Power. A total of seventeen tubes and one transistor are used.

The use of circuit boards and wiring harnesses provides a clean, compact chassis layout and greatly simplifies kit assembly.

## STEP-BY-STEP ASSEMBLY

Before starting to assemble this kit, read the "Kit Builders Guide" for complete information on wiring, soldering, and Step-By-Step Assembly procedures.

There are two separate Parts Lists in this Manual. One Parts List, which contains the circuit board parts, is located just before the Circuit Board Assembly section. The other Parts List contains the chassis parts, and is located just before the Chassis Assembly section of the Manual.

At the beginning of each Parts List, the instructions will tell you which box of parts to open. To avoid intermixing the parts, do not open the other boxes until directed to do so. The large parts that are not packed in separate bags, such as the chassis, cabinet, etc., should be set aside until called for in a Parts List.

Use 1/2 watt resistors unless directed otherwise in the steps. All resistors will be called out by only the resistance value (in  $\Omega$ ,  $K\Omega$ , or megohm) and color code. Capacitors will be called out by only the capacitance value and type or color code.

All color references throughout the Manual are abbreviated according to the following list:

Blk = black	Grn = green
Brn = brown	Blu = blue
Red = red	Viol = violet
Org = orange	Gry = gray
Yel = yellow	Wht = white

### CIRCUIT BOARD PARTS LIST

Unpack box #1, then check each part against the following Parts List. The numbers in color correspond to the numbers in the Parts Pictorials. Refer to the Kit Builders Guide for unpacking instructions, and for instructions on how to identify resistors and capacitors.

PART NO.	QUANTITY	DESCRIPTION
<b>RESISTORS</b>		
<b>1/2 Watt</b>		
1-1	7	47 $\Omega$ (yel-viol-blk)
1-3	6	100 $\Omega$ (brn-blk-brn)
1-45	4	220 $\Omega$ (red-red-brn)
1-9	14	1000 $\Omega$ (brn-blk-red)
1-93	1	1800 $\Omega$ (brn-gry-red)
1-44	3	2200 $\Omega$ (red-red-red)
1-46	2	3900 $\Omega$ (org-wht-red)
1-18	2	5600 $\Omega$ (grn-blu-red)
1-20	3	10 $K\Omega$ (brn-blk-org)
1-109	1	12 $K\Omega$ (brn-red-org)

PART NO.	QUANTITY	DESCRIPTION
1-21	2	15 $K\Omega$ (brn-grn-org)
1-89	1	18 $K\Omega$ (brn-gry-org)
1-22	2	22 $K\Omega$ (red-red-org)
1-67	1	39 $K\Omega$ (org-wht-org)
1-25	13	47 $K\Omega$ (yel-viol-org)
1-60	3	68 $K\Omega$ (blu-gry-org)
1-26	7	100 $K\Omega$ (brn-blk-yel)
1-29	6	220 $K\Omega$ (red-red-yel)
1-33	1	470 $K\Omega$ (yel-viol-yel)
1-100	1	510 $K\Omega$ (grn-brn-yel)
1-34	1	680 $K\Omega$ (blu-gry-yel)
1-35	9	1 megohm (brn-blk-grn)

PART NO.	QUANTITY	DESCRIPTION
1-38	4	3.3 megohm (org-org-grn)
1-40	1	10 megohm (brn-blk-blu)
<b>2 Watt</b>		
1-11-2	1	22 $K\Omega$ (red-red-org)
1-10-2	1	47 $K\Omega$ (yel-viol-org)

#### PARTS PICTORIAL

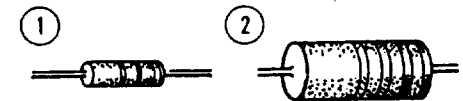

**PART NO. QUANTITY DESCRIPTION**

**CAPACITORS**

**Mica**

20-52	4	3	7.5 $\mu\mu\text{f}$
20-118	1		15 $\mu\mu\text{f}$
20-99	4		22 $\mu\mu\text{f}$
20-97	3		50 $\mu\mu\text{f}$
20-109	1		62 $\mu\mu\text{f}$
20-102	2		100 $\mu\mu\text{f}$
20-103	1		150 $\mu\mu\text{f}$
20-107	2		680 $\mu\mu\text{f}$

**Disc**

21-33	1	4	3.3 $\mu\mu\text{f}$
21-78	1		5 $\mu\mu\text{f}$
21-61	1		6.8 $\mu\mu\text{f}$
21-60	1		18 $\mu\mu\text{f}$
21-13	4		500 $\mu\mu\text{f}$
21-14	8		.001 $\mu\text{fd}$
21-57	19		.005 $\mu\text{fd}$ 500 V
21-72	1		.005 $\mu\text{fd}$ 1.4 KV
21-16	24		.01 $\mu\text{fd}$
21-31	2		.02 $\mu\text{fd}$

**Electrolytic**

25-54	1	5	10 $\mu\text{fd}$
25-115	2	6	10 $\mu\text{fd}$
25-135	1	7	20 $\mu\text{fd}$
25-117	1		100 $\mu\text{fd}$

**Other Capacitors**

21-29	1	8	4.7 $\mu\mu\text{f}$ tubular
21-41	3	9	14 $\mu\mu\text{f}$ tubular (brn-yel-blk)
26-93	1	10	1.8-13 $\mu\mu\text{f}$ variable
27-47	2	11	.1 $\mu\text{fd}$ resin *(brn-blk-yel)
27-34	5		.2 $\mu\text{fd}$ resin
28-2	1	12	1 $\mu\text{fd}$ phenolic (brn-blk-wht)
28-1	2		2.2 $\mu\text{fd}$ phenolic (red-red-wht)
31-36	2	13	8-50 $\mu\mu\text{f}$ trimmer

\*See Color Code Chart (Page 5).

**PART NO. QUANTITY DESCRIPTION**

**COILS**

40-672	4	14	.415 $\mu\text{h}$ (red coil form)
40-670	1		.47 $\mu\text{h}$ (grn coil form)
40-668	3		.65 $\mu\text{h}$ (yel coil form)
40-671	4		.72 $\mu\text{h}$ (wht coil form)
40-667	1		.73 $\mu\text{h}$ (org coil form)
40-666	1		8.7 $\mu\text{h}$ (brn coil form-wax covered)

**TRANSFORMERS**

52-70	1	15	3.395 mc balanced modulator
52-88	1		3.395 mc interstage
52-79	1		3.395 mc product detector
52-65	2	16	8.4-8.9 mc bandpass coupler

**DIODES**

56-26-1	9	17	1N191 germanium (brn-wht-brn)
56-28	3		S187 silicon
56-25	1	18	1N-4166A zener, 15 V
57-29	2		Silicon rectifier, 750 ma 100 PIV

**SOCKETS**

434-101	1	19	Transistor
434-149	2	20	Nuvistor tube
434-129	1	21	7-pin tube
434-130	8		9-pin tube
434-74	1	22	Crystal

**PARTS PICTORIAL**

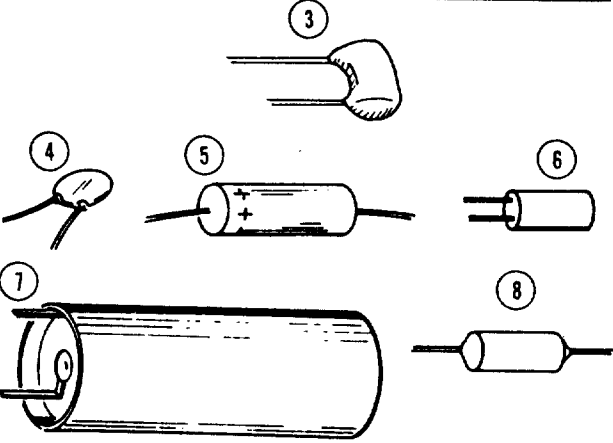

**PARTS PICTORIAL**

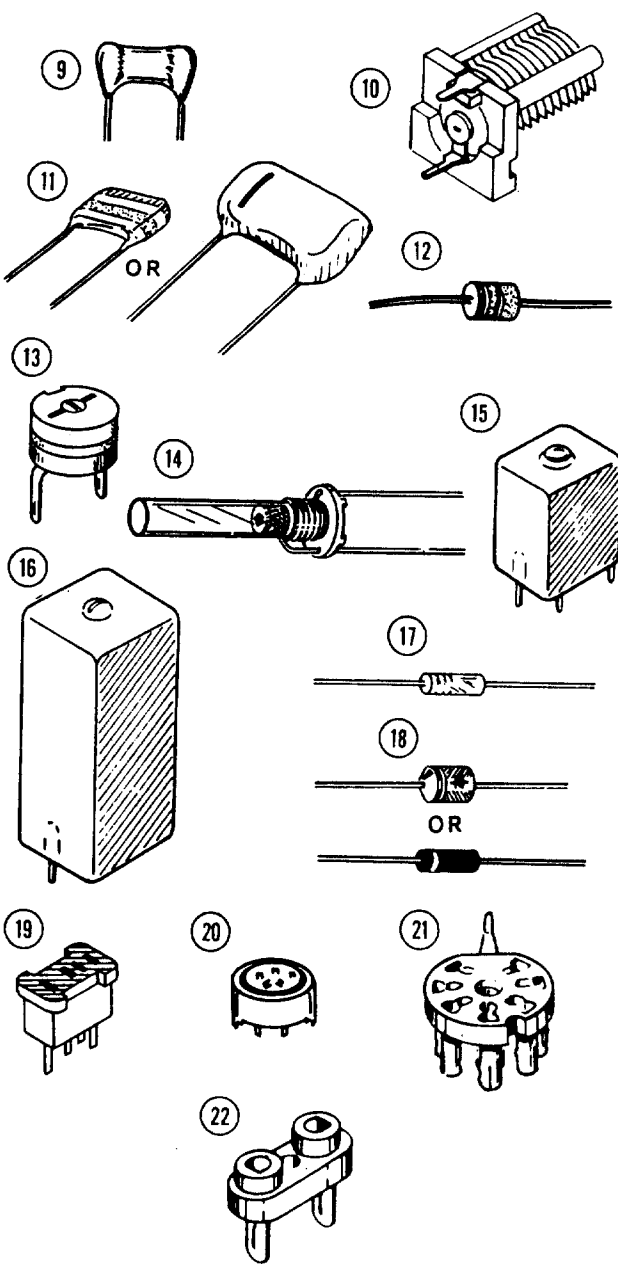

**PART NO. QUANTITY DESCRIPTION**

**CRYSTALS**

404-43	1	23	100 kc
404-205	1		3393,6 kc
404-263	1		3394,4 kc
404-206	1		3396,4 kc

**CIRCUIT BOARDS**

85-114-1	1		Receiver RF
85-115-2	1		Receiver IF
85-116-1	1		Oscillator coil
85-152-1	1		Carrier generator
85-118-1	1		Transmitter mixer
85-119-1	1		Noise limiter

**HARDWARE**

250-133	1	24	3-48 x 7/16" screw
252-1	1	25	3-48 nut

**MISCELLANEOUS**

10-147	2	26	200 Ω miniature control
40-581	2	27	620 μh RF choke
45-39	1	28	4.65 μh RF choke

**PART NO. QUANTITY DESCRIPTION**

**MISCELLANEOUS (cont'd.)**

84-22	1	29	P.E.C. (printed electronic circuit)
206-244	14	30	Coil shield
345-1	1		Flat braid
417-67	1	31	2N2712 transistor
490-5	1	32	Nut starter *
597-308	1		Kit Builders Guide Manual (See front cover for part number.)
			Solder

\*See Kit Builders Guide.

EXAMPLE

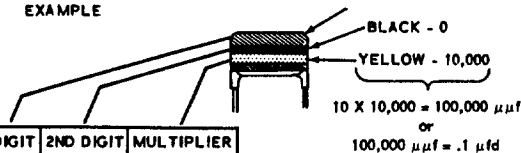

COLOR	1ST DIGIT	2ND DIGIT	MULTIPLIER
BLACK	0	0	1
BROWN	1	1	10
RED	2	2	100
ORANGE	3	3	1,000
YELLOW	4	4	10,000
GREEN	5	5	100,000
BLUE	6	6	1,000,000
VIOLET	7	7	10,000,000
GRAY	8	8	100,000,000
WHITE	9	9	1,000,000,000

**PARTS PICTORIAL**

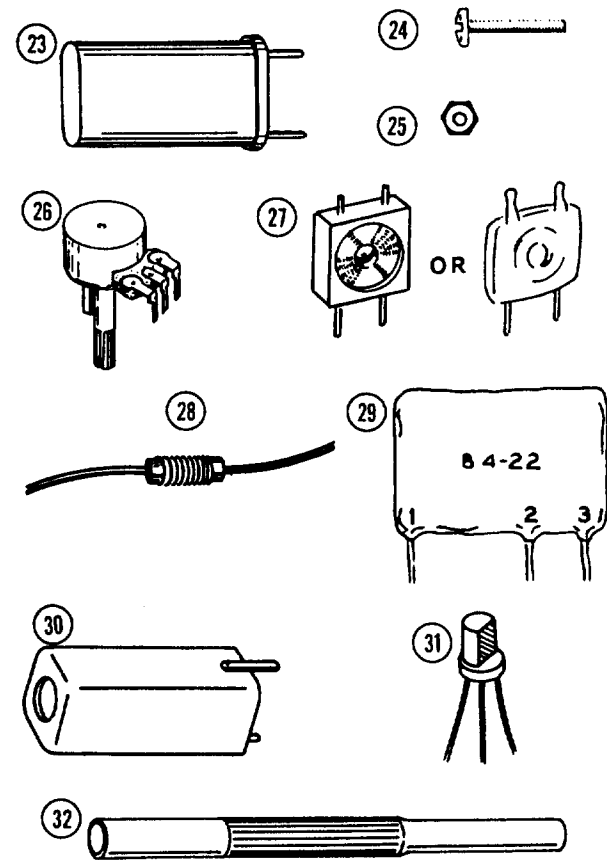

**CIRCUIT BOARD ASSEMBLY**

Review the wiring and soldering instructions for circuit boards, that are covered in the separate Kit Builders Guide, before beginning the assembly of the circuit boards.

Be especially careful not to cover unused holes, or to bridge solder between foils, during the assembly of the circuit boards.

In some instances, resistors and capacitors will be mounted vertically.

Position all parts as shown in the Pictorials. Also, some resistors and capacitors are mounted only with one lead. Follow the instructions carefully.

In steps where coils, chokes, or other parts are installed, only the description of the part will be used; the words install, connect, and mount are generally omitted.

**OSCILLATOR COIL CIRCUIT BOARD,  
#85-116-1**

NOTE: When installing the coils, position the lead from the top of the winding in the hole indicated by the arrow.

Solder the pins of each coil as it is installed.

DO NOT CUT OFF ANY OF THE COIL LEADS UNTIL DIRECTED TO DO SO.

Do not solder the pins of the coil shields until all the shields are installed.

NOTE: Remove and discard the insulating lining from the inside of eight coil shields.

( ) Coil #40-672 (red) and coil shield.

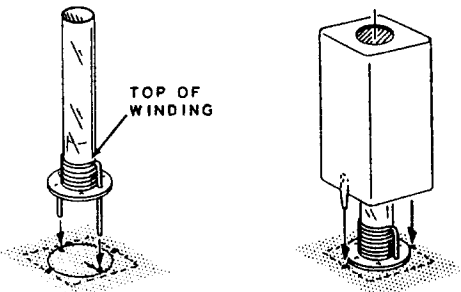

( ) Coil #40-672 (red) and coil shield.

( ) 1000  $\Omega$  (brn-blk-red).

( ) .005  $\mu$ fd disc. Do not use the .005  $\mu$ fd 1.4 KV capacitor until it is called for.

( ) Coil #40-671 (wht) and coil shield.

( ) Coil #40-671 (wht) and coil shield.

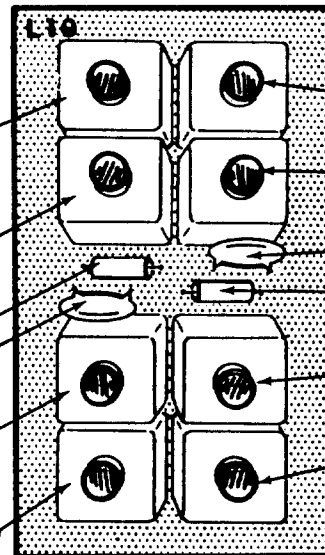

( ) Coil #40-672 (red) and coil shield.

( ) Coil #40-672 (red) and coil shield.

( ) .005  $\mu$ fd disc.

( ) 1000  $\Omega$  (brn-blk-red).

( ) Coil #40-671 (wht) and coil shield.

( ) Coil #40-671 (wht) and coil shield.

( ) Check to see that all connections are soldered, including the coil shields, and cut off the excess resistor and capacitor leads only.

CUT OFF ONLY THE COIL LEADS THAT DO NOT HAVE LETTERS IN THE FOIL. The leads that have letters in the foil will be connected later.

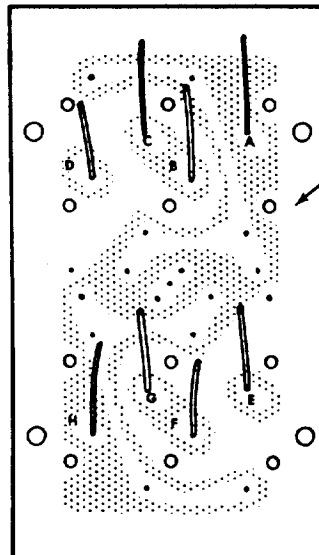

PICTORIAL 1-1



RECEIVER RF CIRCUIT BOARD,  
#85-114-1

- ( ) 100  $\Omega$  (brn-blk-brn).
- ( ) 1 megohm (brn-blk-grn).
- ( ) 100 K $\Omega$  (brn-blk-yel).
- ( ) 680  $\mu$ mf mica.
- ( ) 62  $\mu$ mf mica.
- ( ) 10 K $\Omega$  (brn-blk-org).
- ( ) 18  $\mu$ mf disc.
- ( ) .005  $\mu$ fd disc.
- ( ) 47 K $\Omega$  (yel-viol-org).
- ( ) 1000  $\Omega$  (brn-blk-red).
- ( ) 7.5  $\mu$ mf mica.
- ( ) .001  $\mu$ fd disc.
- ( ) .001  $\mu$ fd disc.
- ( ) 47 K $\Omega$  2 watt (yel-viol-org).
- This resistor to be installed later.
- ( ) .005  $\mu$ fd disc.
- ( ) .005  $\mu$ fd disc.
- ( ) .001  $\mu$ fd disc.
- ( ) 4.7  $\mu$ mf tubular.
- ( ) .001  $\mu$ fd disc.
- ( ) 47 K $\Omega$  (yel-viol-org).

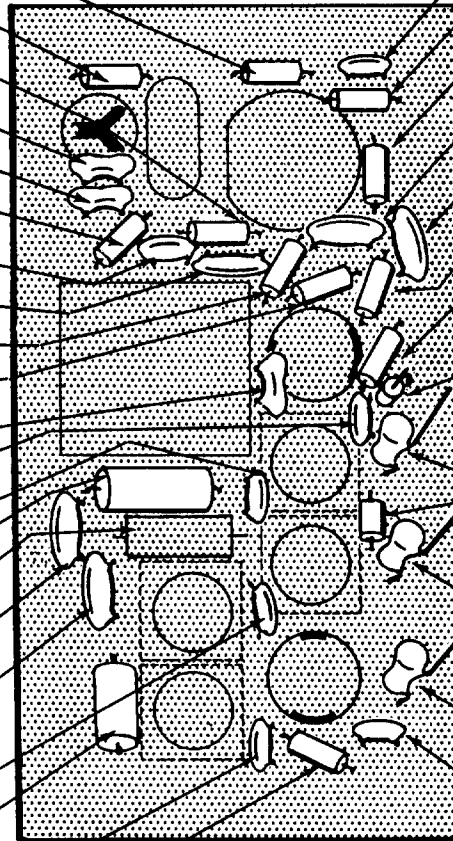

PICTORIAL 1-2

- ( ) .001  $\mu$ fd disc.
  - ( ) 1000  $\Omega$  (brn-blk-red).
  - ( ) 3900  $\Omega$  (org-wht-red).
  - ( ) .005  $\mu$ fd disc.
  - ( ) .005  $\mu$ fd disc.
  - ( ) 47  $\Omega$  (yel-viol-blk).
  - ( ) 47 K $\Omega$  (yel-viol-org).
  - ( ) 100 K $\Omega$  (brn-blk-yel). Connect only one lead. Cut the other lead to 1/2", and form a loop in the end as shown.
- 1/2"

FORM A LOOP
- ( ) 14  $\mu$ mf tubular (brn-yel-blk). Connect only one lead. The other lead will be connected later.
  - ( ) 1  $\mu$ mf phenolic (brn-blk-wht).
  - ( ) 14  $\mu$ mf tubular (brn-yel-blk). Connect only one lead. The other lead will be connected later.
  - ( ) 14  $\mu$ mf tubular (brn-yel-blk). Connect only one lead. The other lead will be connected later.
  - ( ) .001  $\mu$ fd disc.
  - ( ) Check to see that all connections are soldered, and cut off excess leads.

Receiver RF Circuit Board - Continued

NOTE: Solder the lugs of each part as it is installed.

- ( ) 8-50  $\mu$ f trimmer, #31-36.

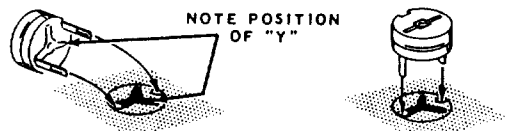

- ( ) Crystal socket. Use a 3-48 x 7/16" screw and a 3-48 nut. Do not over-tighten the hardware.

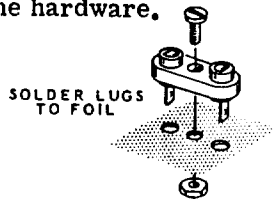

- ( ) Nuvistor tube sockets at V1 and V2. CAUTION: Be sure to position the wide opening of the socket as indicated on the circuit board.

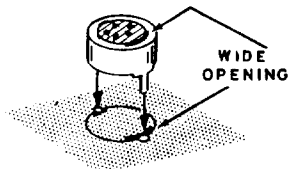

NOTE: When mounting the four coils, position the lead from the top of the winding in the hole indicated by the arrow. Do not solder the pins of the coil shields until all four coils have been installed.

- ( ) Coil #40-666 (brn) wax covered, and coil shield with insulating lining.

NOTE: Remove and discard the insulating lining from the inside of three coil shields.

- ( ) Coil #40-667 (org) and coil shield.

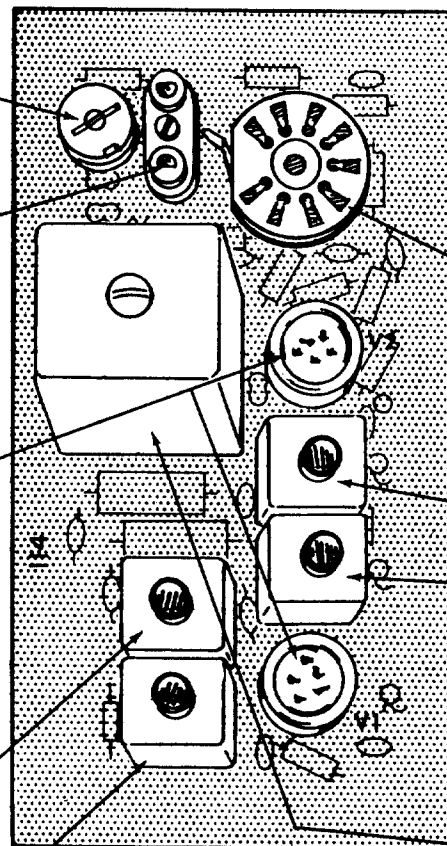

PICTORIAL 1-3

- ( ) Solder the center pin to the ground clip on all the 7 and 9-pin tube sockets before they are mounted.

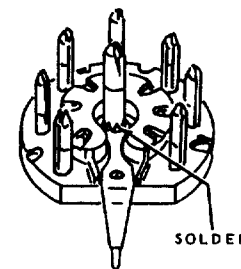

- ( ) 9-pin tube socket. Position the socket as shown. Solder all 10 pins.

ALIGN ALL PINS TO THEIR RESPECTIVE HOLES.

PRESS THE SOCKET DOWN UNTIL IT SNAPS INTO PLACE.

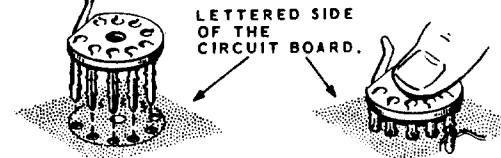

- ( ) Coil #40-668 (yel) and coil shield.

- ( ) Coil #40-668 (yel) and coil shield.

- ( ) Now solder all four coil shields.

- ( ) Transformer #52-65.

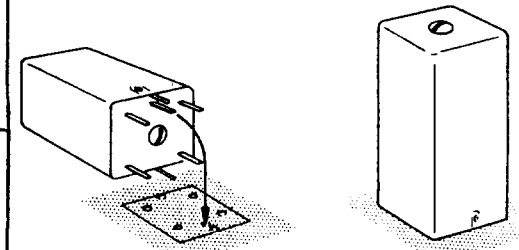

- ( ) Check to see that all connections are soldered.

RECEIVER IF CIRCUIT BOARD,  
#85-115-2

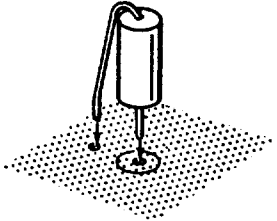
- ( ) 100  $\Omega$  (brn-blk-brn).
- ( ) 47  $\Omega$  (yel-viol-blk).
- ( ) 1800  $\Omega$  (brn-gry-red).
- 
- ( ) 1000  $\Omega$  (brn-blk-red).
- ( ) 5600  $\Omega$  (grn-blu-red).
- ( ) 47 K $\Omega$  (yel-viol-org).
- ( ) 68 K $\Omega$  (blu-gry-org).
- ( ) 220  $\Omega$  (red-red-brn).
- ( ) 1 megohm (brn-blk-grn).
- ( ) 10 megohm (brn-blk-blu).
- ( ) 100  $\Omega$  (brn-blk-brn).
- ( ) 680 K $\Omega$  (blu-gry-yel).
- ( ) 47 K $\Omega$  (yel-viol-org).
- ( ) 100 K $\Omega$  (brn-blk-yel).
- ( ) 47  $\Omega$  (yel-viol-blk).
- ( ) 2200  $\Omega$  (red-red-red).
- ( ) 100 K $\Omega$  (brn-blk-yel).

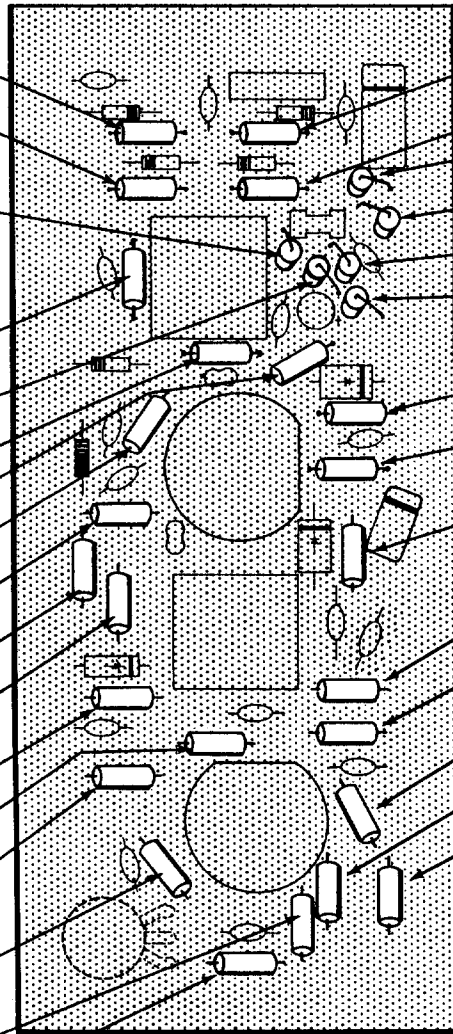

- ( ) 100  $\Omega$  (brn-blk-brn).
- ( ) 47  $\Omega$  (yel-viol-blk).
- ( ) 22 K $\Omega$  (red-red-org).
- ( ) 220 K $\Omega$  (red-red-yel).
- ( ) 22 K $\Omega$  (red-red-org).
- ( ) 68 K $\Omega$  (blu-gry-org).
- ( ) 1 megohm (brn-blk-grn).
- ( ) 1 megohm (brn-blk-grn).
- ( ) 100 K $\Omega$  (brn-blk-yel).
- ( ) 1000  $\Omega$  (brn-blk-red).
- ( ) 68 K $\Omega$  (blu-gry-org).
- ( ) 1 megohm (brn-blk-grn).
- ( ) 220  $\Omega$  (red-red-brn).
- ( ) 47 K $\Omega$  (yel-viol-org).
- ( ) Check to see that all connections are soldered, and cut off excess leads.

PICTORIAL 1-4

Receiver IF Circuit Board - Continued

- ( ) .005  $\mu$ fd disc.
- ( ) .01  $\mu$ fd disc.
- NOTE: When installing diodes, the cathode end should be placed as shown. The cathode end is marked with either a color end, color dot, or color band. Bend the leads of glass diodes 1/8" from the ends of the body to prevent breakage.
- ( ) Germanium diode #56-26 (brn-wht-brn). Note banded end.
- ( ) Germanium diode #56-26 (brn-wht-brn). Note banded end.
- ( ) .005  $\mu$ fd disc.
- ( ) Germanium diode #56-26 (brn-wht-brn). Note banded end.
- ( ) 7.5  $\mu$ mf mica.
- ( ) Silicon diode #56-28. Note banded end.
- ( ) .005  $\mu$ fd disc.
- ( ) .01  $\mu$ fd disc.
- ( ) 100  $\mu$ mf mica.
- ( ) Zener diode #56-25. Note body marking.
- ( ) .005  $\mu$ fd disc.
- ( ) .01  $\mu$ fd disc.

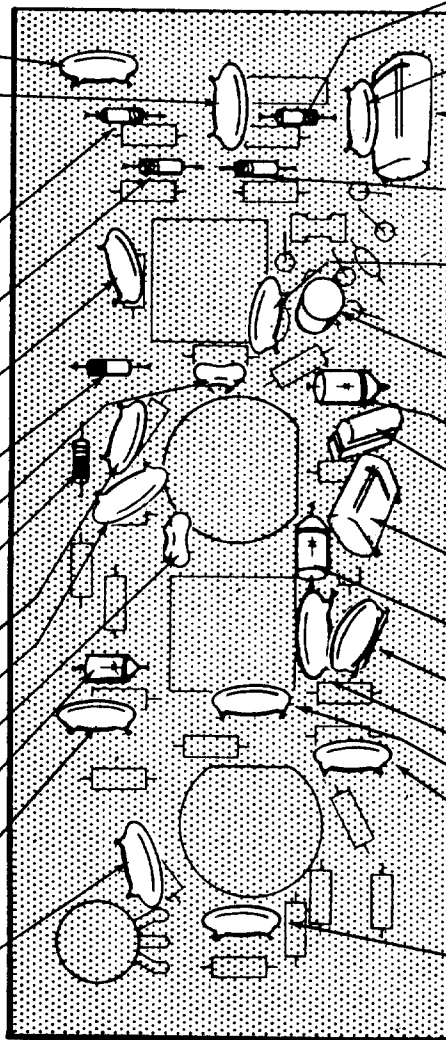

PICTORIAL 1-5

- ( ) Germanium diode #56-26 (brn-wht-brn). Note banded end.
- ( ) .005  $\mu$ fd disc.
- NOTE: When installing resin capacitors having a banded end, position the banded end as shown.
- ( ) .2  $\mu$ fd resin. Note banded end.
- ( ) Germanium diode #56-26 (brn-wht-brn). Note banded end.
- ( ) .005  $\mu$ fd disc.
- NOTE: When installing electrolytic capacitors, position the positive (+) lead in the (+) marked hole in the circuit board.
- ( ) 10  $\mu$ fd electrolytic. Note (+) markings.
- ( ) Silicon rectifier #57-29. Note banded end.
- ( ) .1  $\mu$ fd resin.
- ( ) .2  $\mu$ fd resin. Note banded end.
- ( ) Silicon rectifier #57-29. Note banded end.
- ( ) 500  $\mu$ mf disc.
- ( ) .01  $\mu$ fd disc.
- ( ) .005  $\mu$ fd disc.
- ( ) .005  $\mu$ fd disc.
- ( ) .005  $\mu$ fd disc.
- ( ) Check to see that all connections are soldered, and cut off excess leads.

Receiver IF Circuit Board - Continued

NOTE: Solder the lugs of each part as it is installed.

( ) Transistor socket. Position the socket as shown.

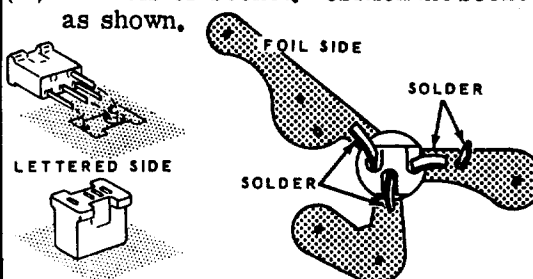

( ) .1  $\mu$ fd resin.

( ) 9-pin tube socket.

( ) 9-pin tube socket.

( ) 200  $\Omega$  miniature control.

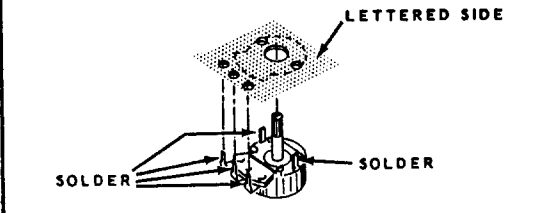
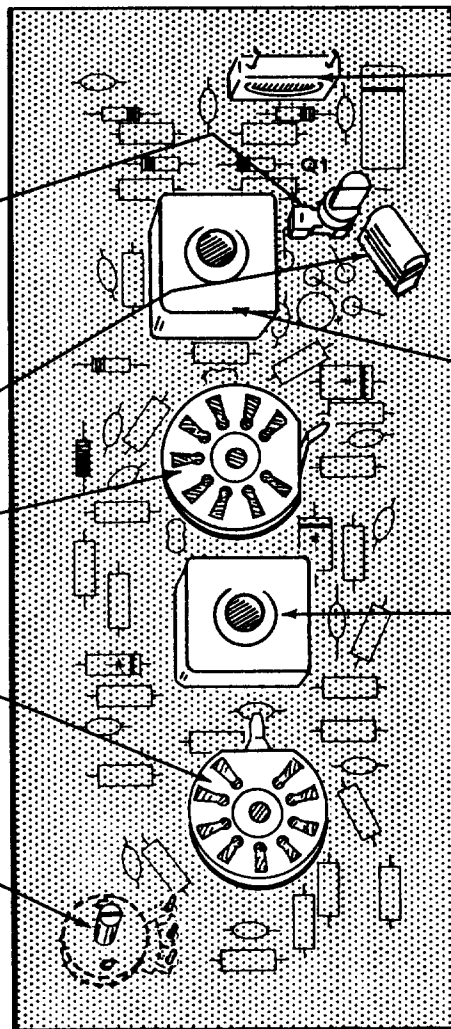
( ) 620  $\mu$ h RF choke, #40-581.

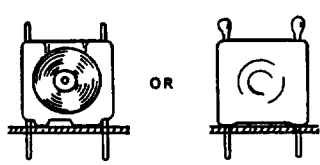

( ) Transformer #52-79.

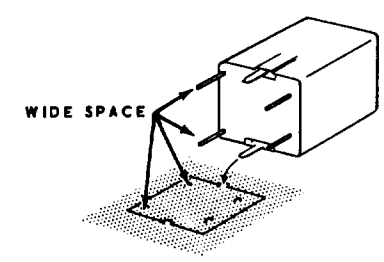

( ) Transformer #52-88.

( ) Cut the leads of the 2N2712 transistor to 5/16".

( ) Install this transistor in socket Q1.



( ) Check to see that all connections are soldered.

PICTORIAL 1-6

NOISE LIMITER CIRCUIT BOARD,  
#85-119-1

- ( ) .01  $\mu$ fd disc.
- ( ) .01  $\mu$ fd disc.

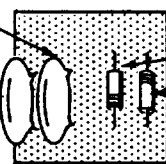

- ( ) Silicon diode, #56-28, Note banded end.
- ( ) Silicon diode, #56-28, Note banded end.
- ( ) Check to see that all connections are soldered, and cut off excess leads.

PICTORIAL 1-7

NOISE LIMITER CIRCUIT BOARD TO  
RECEIVER IF CIRCUIT BOARD

- ( ) Position the X and Y foils of the noise limiter circuit board against the corresponding X and Y pins that extend from the foil side of the receiver IF circuit board. While holding the noise limiter circuit board perpendicular to the receiver IF circuit board, solder the two connections.

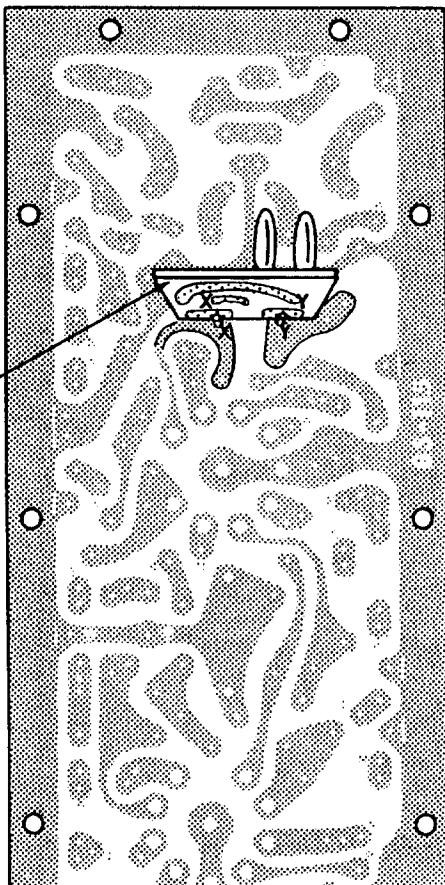

PICTORIAL 1-8

TRANSMITTER-MIXER CIRCUIT BOARD,  
#85-118-1

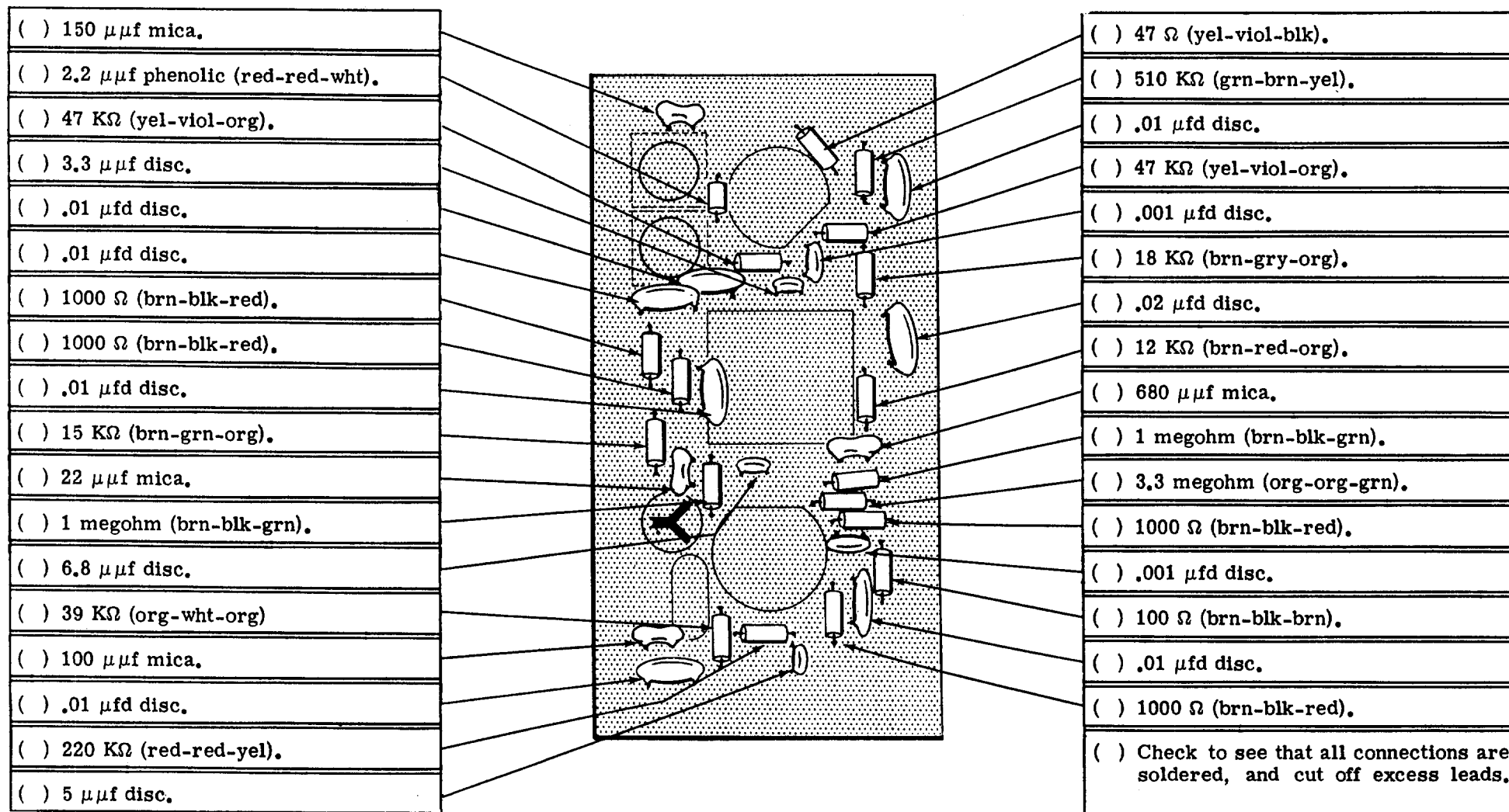

PICTORIAL 1-9

Transmitter-Mixer Circuit Board -  
Continued

NOTE: Solder the lugs of each part as it is installed.

( ) 7-pin tube socket.

( ) 9-pin tube socket.

( ) 8-50  $\mu\mu\text{f}$  trimmer, #31-36. Note the position of the "Y" on the trimmer and the circuit board.

( ) 100 kc crystal, #404-43. Solder the pins to the circuit board foil.

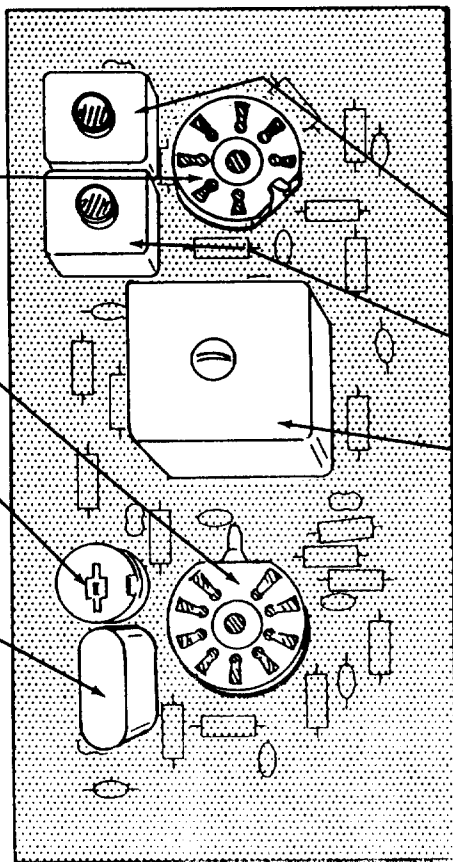
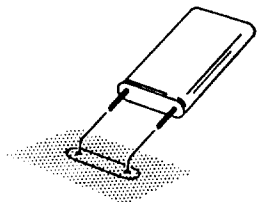

NOTE: When installing the coils, position the lead from the top of the winding in the hole indicated by the arrow. Solder the pins of each part as it is installed. Do not solder the pins of the coil shields until both coils have been installed.

( ) Remove and discard the insulating lining from the inside of two coil shields.

( ) Coil #40-670 (grn) and coil shield.

( ) Coil #40-668 (yel) and coil shield.

( ) Transformer #52-65.

( ) Check to see that all connections are soldered.

PICTORIAL 1-10



**CARRIER GENERATOR CIRCUIT BOARD,  
#85-152-1**

- ( ) 1 megohm (brn-blk-grn).
- ( ) 4,65  $\mu$ h RF choke, #45-39.
- ( ) 1000  $\Omega$  (brn-blk-red).
- ( ) 1 megohm (brn-blk-grn).
- ( ) 22 K $\Omega$  2 watt (red-red-org).
- ( ) 470 K $\Omega$  (yel-viol-yel).
- ( ) 47 K $\Omega$  (yel-viol-org).
- ( ) 3,3 megohm (org-org-grn).
- ( ) 5600  $\Omega$  (grn-blu-red).
- ( ) 3,3 megohm (org-org-grn).
- ( ) 3,3 megohm (org-org-grn).
- ( ) 10 K $\Omega$  (brn-blk-org).
- ( ) 220  $\Omega$  (red-red-brn).
- ( ) 1000  $\Omega$  (brn-blk-red).
- ( ) 47 K $\Omega$  (yel-viol-org).
- ( ) 3900  $\Omega$  (org-wht-red).
- ( ) 47 K $\Omega$  (yel-viol-org).
- ( ) 47  $\Omega$  (yel-viol-blk).
- ( ) 2200  $\Omega$  (red-red-red).
- ( ) 100 K $\Omega$  (brn-blk-yel).

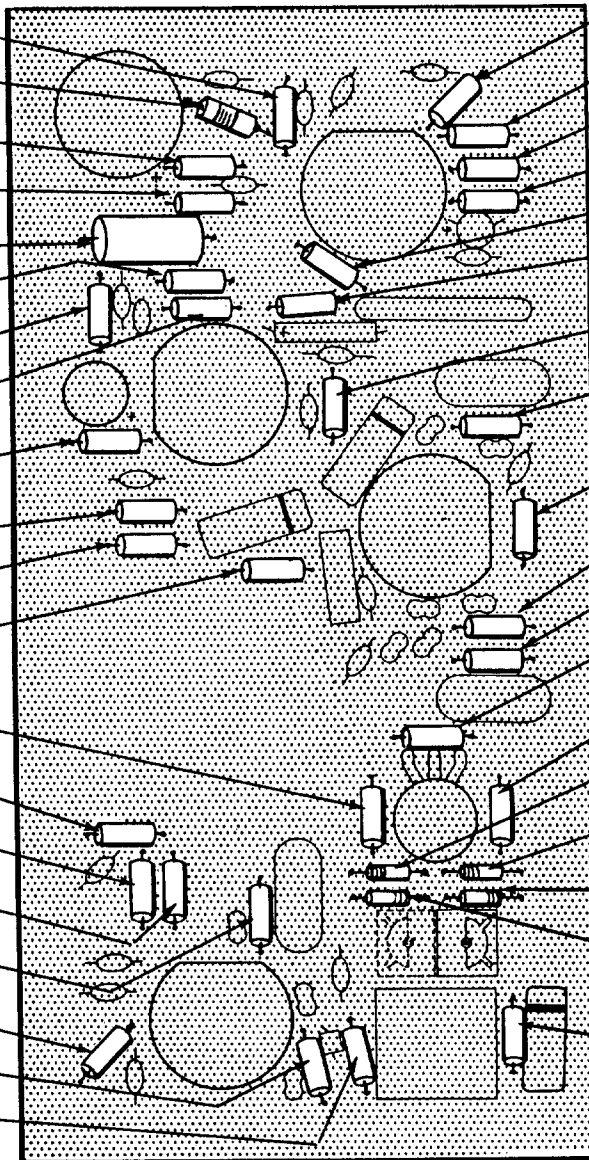

- ( ) 220 K $\Omega$  (red-red-yel).
- ( ) 220 K $\Omega$  (red-red-yel).
- ( ) 1000  $\Omega$  (brn-blk-red).
- ( ) 1000  $\Omega$  (brn-blk-red).
- ( ) 220 K $\Omega$  (red-red-yel).
- ( ) 100  $\Omega$  (brn-blk-brn).
- ( ) 220 K $\Omega$  (red-red-yel).
- ( ) 47 K $\Omega$  (yel-viol-org).
- ( ) 10 K $\Omega$  (brn-blk-org).
- ( ) 2200  $\Omega$  (red-red-red).
- ( ) 47 K $\Omega$  (yel-viol-org).
- ( ) 47  $\Omega$  (yel-viol-blk).
- ( ) 220  $\Omega$  (red-red-brn).
- ( ) Germanium diode #56-26 (brn-wht-brn). Note banded end.
- ( ) Germanium diode #56-26 (brn-wht-brn). Note banded end.
- ( ) Germanium diode #56-26 (brn-wht-brn). Note banded end.
- ( ) Germanium diode #56-26 (brn-wht-brn). Note banded end.
- ( ) 100 K $\Omega$  (brn-blk-yel).
- ( ) Check to see that all connections are soldered, and cut off excess leads.

PICTORIAL 1-11

Carrier Generator Circuit Board -  
Continued

- ( ) .01  $\mu$ fd disc.
- ( ) 500  $\mu$ fd disc.
- ( ) .01  $\mu$ fd disc.
- ( ) .005  $\mu$ fd 1,4 KV disc.
- ( ) .005  $\mu$ fd disc.
- ( ) 100  $\mu$ fd electrolytic. Note (+) markings.
- ( ) 500  $\mu$ fd disc.
- ( ) .01  $\mu$ fd disc.
- ( ) .2  $\mu$ fd resin. Note banded end.
- ( ) .01  $\mu$ fd disc.
- ( ) .01  $\mu$ fd disc.
- ( ) 15  $\mu$ fd mica.
- ( ) .01  $\mu$ fd disc.
- ( ) .01  $\mu$ fd disc.
- ( ) .005  $\mu$ fd disc.
- ( ) .01  $\mu$ fd disc.
- ( ) 22  $\mu$ fd mica.
- ( ) .01  $\mu$ fd disc.
- ( ) 50  $\mu$ fd mica.

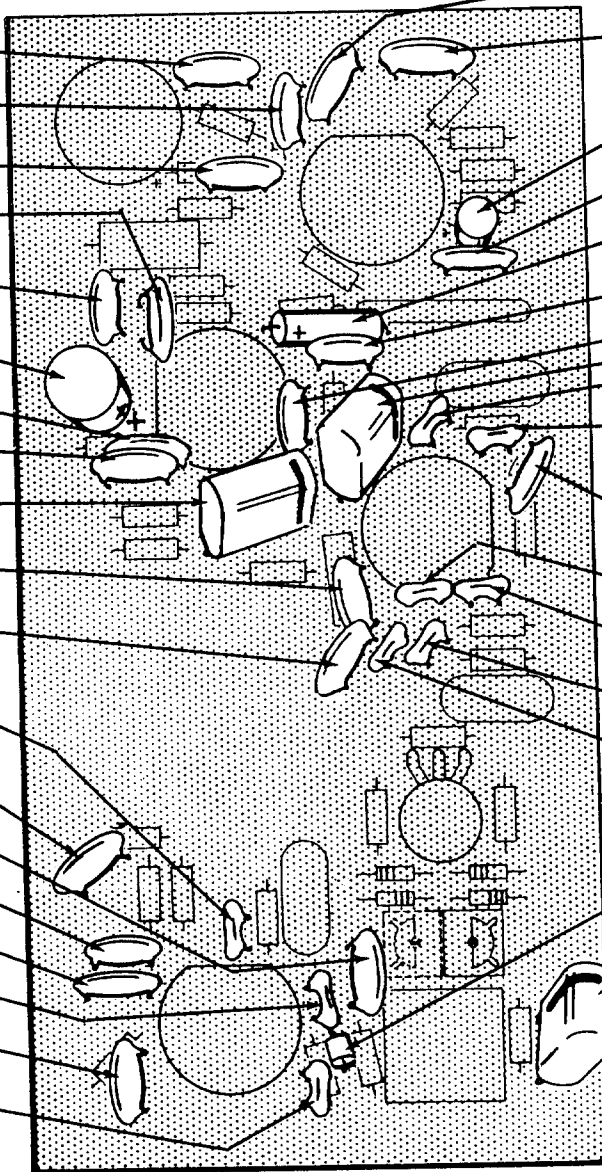

- ( ) .01  $\mu$ fd disc.
- ( ) .02  $\mu$ fd disc.
- ( ) 10  $\mu$ fd electrolytic. Note (+) markings.
- ( ) .01  $\mu$ fd disc.
- ( ) 10  $\mu$ fd electrolytic. Note (+) markings.
- ( ) 500  $\mu$ fd disc.
- ( ) .005  $\mu$ fd disc.
- ( ) .2  $\mu$ fd resin. Note banded end.
- ( ) 22  $\mu$ fd mica.
- ( ) 7.5  $\mu$ fd mica.
- ( ) .01  $\mu$ fd disc.
- ( ) 22  $\mu$ fd mica.
- ( ) 50  $\mu$ fd mica.
- ( ) 50  $\mu$ fd mica.
- ( ) 7.5  $\mu$ fd mica.
- ( ) 2.2  $\mu$ fd phenolic (red-red-wht).
- ( ) .2  $\mu$ fd resin. Note banded end.
- ( ) Check to see that all connections are soldered, and cut off excess leads.

PICTORIAL 1-12

Carrier Generator Circuit Board -  
Continued

NOTE: Solder the lugs of each part as it is installed.

( ) 9-pin tube sockets at V6, V8, V9, and V10.

( ) 20  $\mu$ f electrolytic. Note (+) markings.

( ) P.E.C. #84-22.

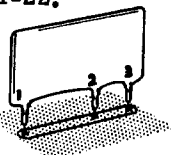

( ) 3393.6 kc crystal, #404-205.

( ) 620  $\mu$ h RF choke #40-581.

( ) 3396.4 kc crystal, #404-206.

( ) 200  $\Omega$  miniature control.

( ) 3394.4 kc crystal, #404-263.

( ) Variable capacitor #26-93. Position as shown.

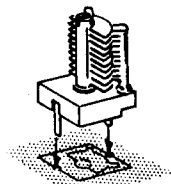

( ) Transformer #52-70.

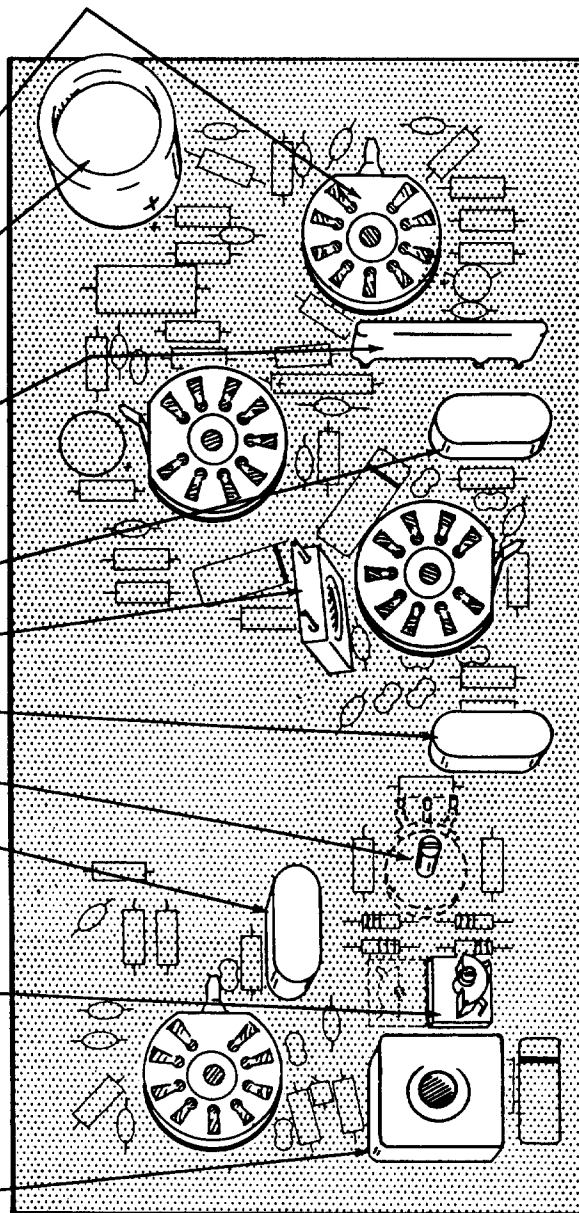

( ) Form a 1-1/2" length of flat braid as shown in the inset drawing below.

( ) Install this length of flat braid between the two indicated foils. Solder the braid directly to these foils. Be sure the braid does not get pushed down against the other foils.

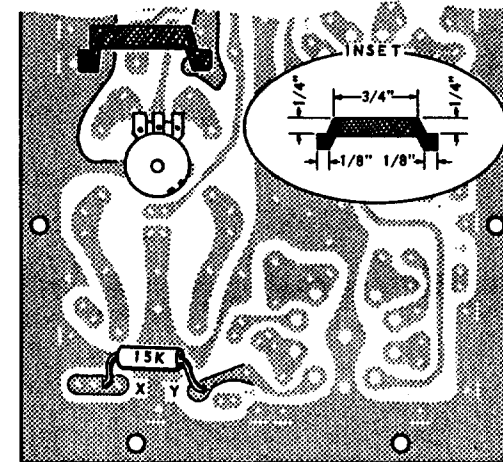

( ) 15 K $\Omega$  (brn-grn-org). Cut each resistor lead to 1/2". Position the resistor between locations X and Y on the foil side of the circuit board. Solder the leads directly to the foil.

( ) Check to see that all connections are soldered. Cut off the excess leads of the P.E.C.

This completes the assembly of the circuit boards. Carefully check to see that all connections are soldered and that no solder bridges exist between foils. Be sure solder has not run all-the-way through the tube socket mounting pins. If solder does extend beyond the top of the socket, reheat the solder so it flows down below the top of the socket.

PICTORIAL 1-13

# CHASSIS PARTS LIST

Unpack the remaining parts, then check each part against the following Parts List. The numbers in color correspond to the numbers in the Parts Pictorials. Any parts packed in individual bags, with parts numbers, should be left in these bags until called for in a step.

PART NO.	QUANTITY	DESCRIPTION
----------	----------	-------------

## RESISTORS

### 1/2 Watt

1-41	6	1	10 $\Omega$ (brn-blk-blk)
1-1	1		47 $\Omega$ (yel-viol-blk) spare
1-3	1		100 $\Omega$ (brn-blk-brn)
1-45	3		220 $\Omega$ (red-red-brn)
1-48	2		390 $\Omega$ (org-wht-brn)
1-95	1		560 $\Omega$ (grn-blu-brn)
1-9	1		1000 $\Omega$ (brn-blk-red)
1-16	2		4700 $\Omega$ (yel-viol-red)
1-20	4		10 K $\Omega$ (brn-blk-org)
1-21	1		15 K $\Omega$ (brn-grn-org)
1-22	1		22 K $\Omega$ (red-red-org)
1-25	3		47 K $\Omega$ (yel-viol-org)
1-26	2		100 K $\Omega$ (brn-blk-yel)
1-29	2		220 K $\Omega$ (red-red-yel)
1-34	2		680 K $\Omega$ (blu-gry-yel)
1-35	1		1 megohm (brn-blk-grn)
1-36	1		1.5 megohm (brn-grn-grn)
1-86	1		5.6 megohm (grn-blu-grn)
1-40	1		10 megohm (brn-blk-blu)

### 1 Watt

1-17-1	1	2	100 $\Omega$ (brn-blk-brn)
1-25-1	1		6800 $\Omega$ (blu-gry-red)
1-9-1	1		10 K $\Omega$ (brn-blk-org)

### Other Resistors

1-3-2	1	3	10 K $\Omega$ 2 watt (brn-blk-org)
1-11-2	1		22 K $\Omega$ 2 watt (red-red-org)
1-18-2	1		33 K $\Omega$ 2 watt (org-org-org)
3-19-10	1	4	2000 $\Omega$ 10 watt

PART NO.	QUANTITY	DESCRIPTION
----------	----------	-------------

## CAPACITORS

### Mica

20-52	1	5	7.5 $\mu\text{mf}$
20-99	3		22 $\mu\text{mf}$
20-100	1		30 $\mu\text{mf}$
20-97	2		50 $\mu\text{mf}$
20-78	1		56 $\mu\text{mf}$
20-103	1		150 $\mu\text{mf}$

### Disc

21-78	1	6	5 $\mu\text{mf}$
21-14	18		.001 $\mu\text{fd}$
21-57	9		.005 $\mu\text{fd}$
21-72	3		.005 $\mu\text{fd}$ 1.4 KV
21-16	2		.01 $\mu\text{fd}$
21-31	1		.02 $\mu\text{fd}$

### Feedthrough

21-113	1	7	360 $\mu\text{mf}$ (org-blu-brn)
21-53	9		.001 $\mu\text{fd}$ small (brn-blk-red)
21-59	1		.001 $\mu\text{fd}$ large (brn-blk-red-blk)

### Variable

26-106	2	8	15 $\mu\text{mf}$ 3-section
26-24	1	9	20 $\mu\text{mf}$
26-105	1	10	140 $\mu\text{mf}$

## PARTS PICTORIAL

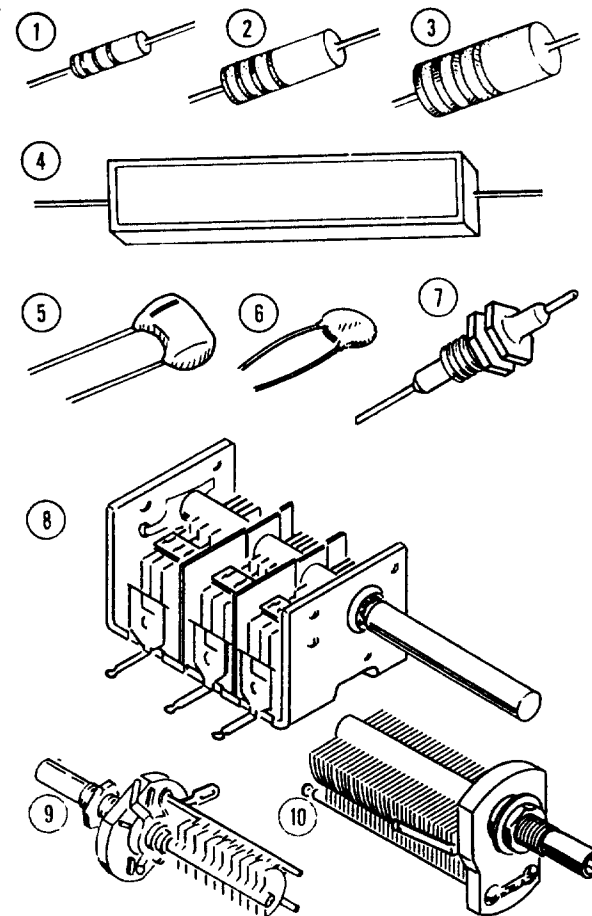

**PART NO. QUANTITY DESCRIPTION**

**Other Capacitors**

21-29	1	11	4.7 $\mu$ f tubular
21-114	1	12	150 $\mu$ f standoff
21-55	1		500 $\mu$ f standoff
27-34	4	13	.2 $\mu$ f resin
28-2	1	14	1 $\mu$ f phenolic (brn-blk-wht)
28-1	1		2.2 $\mu$ f phenolic (red-red-wht)
31-30	1	15	1.5-7 $\mu$ f trimmer
31-31	1		3-12 $\mu$ f trimmer

**CONTROLS**

10-52	1	16	2000 $\Omega$ tab mount
10-57	2		10 K $\Omega$ tab mount
10-60	2		500 K $\Omega$ tab mount
10-153	2	17	1 megohm miniature
10-154	1		10 megohm miniature
12-48	1	18	10 K $\Omega$ -1 megohm dual
19-60	1	19	10 K $\Omega$ with push-pull switch
19-66	1		500 K $\Omega$ with push-pull switch

**SWITCHES**

60-4	1	20	Slide
63-386	1	21	1-section, 3-position rotary
63-385	1		1-section, 3-position rotary with shield
63-383	1		1-section, 4-position rotary with snap switch
63-384	1		2-section, 4-position rotary
63-420	1		3-section, 4-position rotary

**COILS**

40-664	1	22	Final plate
40-673	1	23	Crystal resonating
40-530	1	24	Driver plate

**CHOKES**

45-2	1	25	Final plate
45-19	2	26	Parasitic
45-39	1	27	4.65 $\mu$ h RF
45-51	1		15 $\mu$ h RF
45-36	2	28	7 $\mu$ h (red)
45-35	2	29	Filament

**TRANSFORMER**

51-123	1		Audio output
--------	---	--	--------------

**HEATHKIT®**

**PART NO. QUANTITY DESCRIPTION**

**DIODES**

56-26-1	1	30	1N191 germanium (brn-wht-brn)
57-29	4	31	Silicon rectifier, 750 ma 100 PIV

**INSULATORS**

71-5	1	32	Small ceramic standoff
71-4	1	33	Large ceramic standoff (This part may come dis-assembled in a plastic bag.)
73-4	4	34	5/16" rubber grommet
73-3	3		1/2" rubber grommet

**PARTS PICTORIAL**

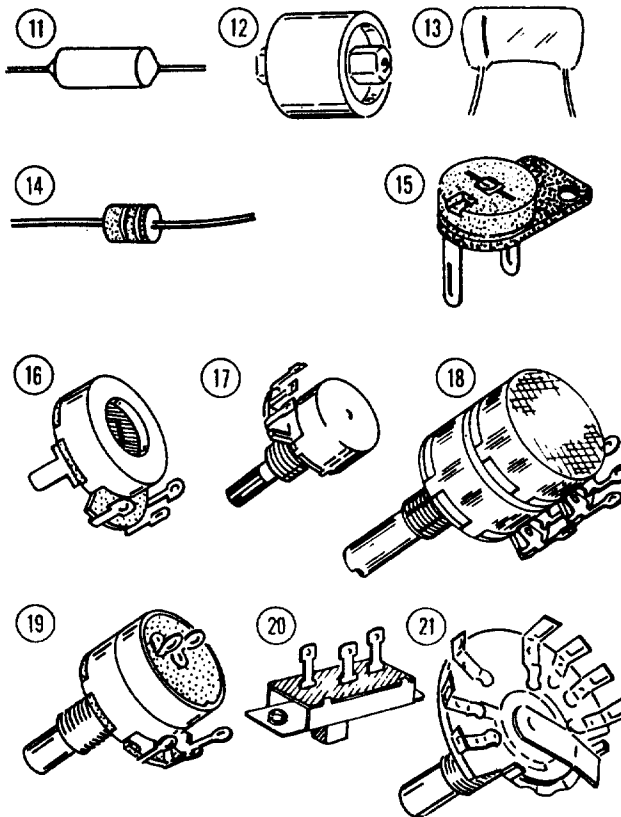

**PARTS PICTORIAL**

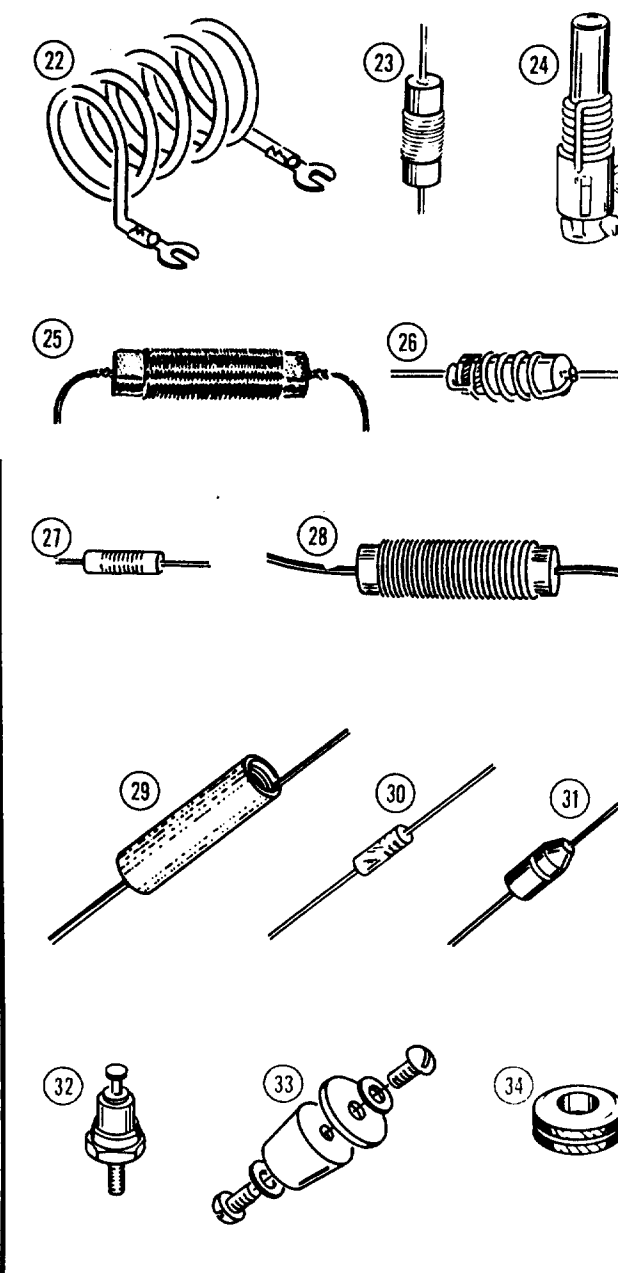

PART NO.	QUANTITY	DESCRIPTION
----------	----------	-------------

### TERMINAL STRIPS

431-57	3	35 2-lug miniature
431-62	2	3-lug miniature
431-2	2	36 2-lug
431-11	1	5-lug
431-69	1	30-lug terminal board

### CONNECTORS-JACKS-PLUGS

432-38	1	37 Male connector
432-39	1	38 Female connector
436-20	1	39 2-lug phone jack
436-21	1	40 4-lug phone jack
438-4	7	41 Phono plug
438-29	1	42 11-pin plug

### SOCKETS

434-34	1	43 7-pin miniature tube
434-36	2	9-pin miniature tube
434-53	2	44 8-pin tube
434-118	1	45 11-pin
434-42	6	46 Phono
434-74	4	47 Crystal
434-85	1	48 Pilot lamp with lead
434-44	2	49 Pilot lamp

### TUBE SHIELDS-HEAT SINK

206-77	1	50 1-3/4" long 3/4" diameter tube shield
206-68	7	1-3/4" long 11/16" diameter tube shield
206-206	1	2" long tube shield
206-3	1	51 1-15/16" long tube shield
206-54	1	2-3/8" long tube shield
206-86	2	52 Pilot lamp shield
215-8	2	53 Nuvistor heat sink

### TUBES-NUVISTORS-PILOT LAMPS

411-59	1	OA2 tube
411-211	2	6AZ8 tube
411-218	1	6AZ8 tube (painted tip)
411-67	1	6CB6 tube
411-182	2	6DS4 nuvistor
411-124	4	6EA8 tube
411-161	1	6EB8 tube

PART NO.	QUANTITY	DESCRIPTION
----------	----------	-------------

### TUBES-NUVISTORS-PILOT LAMPS (cont'd.)

411-24	1	12AT7 tube
411-69	1	12BY7 tube
411-75	2	6146 tube
412-20	2	#47 pilot lamp
412-17	1	#53 pilot lamp

### CRYSTALS-CRYSTAL FILTER

404-264	1	54 41,605 mc crystal
404-265	1	42,105 mc crystal
404-266	1	42,605 mc crystal
404-267	1	43,105 mc crystal
404-283	1	55 3395 kc crystal filter (2,1 kc bandpass)

### PARTS PICTORIAL

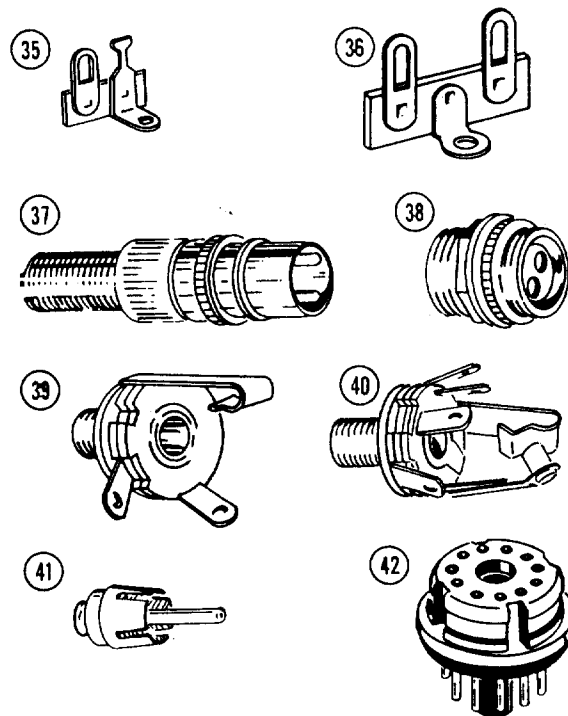

### PARTS PICTORIAL

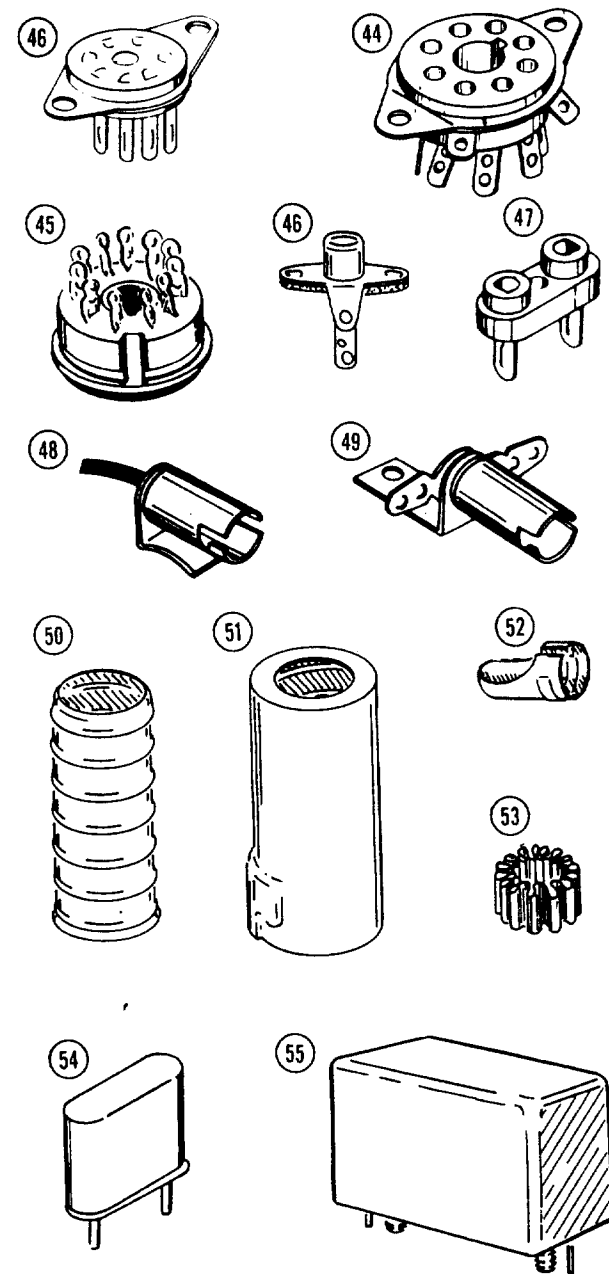

**PART NO. QUANTITY DESCRIPTION**

**SHAFTS-BUSHINGS-SHAFT COUPLINGS**

453-36	1	56	3-7/8" long shaft
453-108	1		8-1/4" long tubular shaft
453-125	1		9-3/8" long shaft
455-11	3	57	Split bushing
455-32	1	58	Dial bushing
455-38	4	59	Threaded bushing
456-7	2	60	Shaft coupling

**KNOBS**

462-175	1	61	7/16" diameter aluminum
462-191	11	62	1-1/8" diameter
462-193	1	63	2-1/2" diameter
462-195	1	64	Lever

**DIAL PARTS**

258-1	1	65	Dial cord spring
349-1	1		Dial cord
446-40	1	66	Dial escutcheon
100-19	1	67	Dial pulley with 1/4" hole
100-458	1		Dial pulley with 9/32" hole (red dot)

**#100-450 Packaged Dial Drive Assembly, Consisting Of The Following:**

204-553	1	68	Dial mounting bracket
100-443	1	69	Dial pointer assembly
464-30-1	1	70	Plastic dial window
100-447	1	71	Dial pointer drive arm
250-63	1	72	3-48 x 1/8" screw
266-74	1	73	Nylon spiral follower
100-445	1	74	Zero set drive pulley (small)
100-449	1	75	Circular dial
100-444	1	76	Dial drive pulley (large)
455-42	1	77	Drive shaft bushing assembly

**CABLE HARNESES-WIRE-SLEEVING**

134-134	1		Wire harness
134-119	1		Coaxial cable harness
340-2	1		Bare wire
343-7	1		Coaxial cable (36")
343-10	1		Teflon* coaxial cable (12")
346-1	1		Small sleeving
346-2	3		Large sleeving

\* DuPont Registered Trademark

**PARTS PICTORIAL**

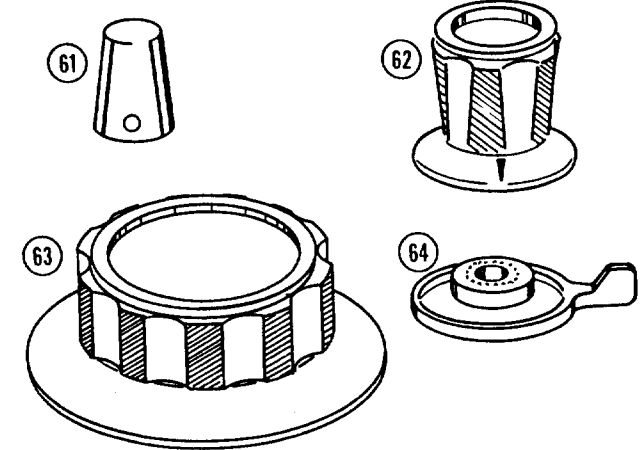
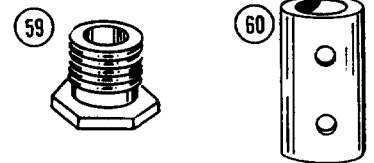
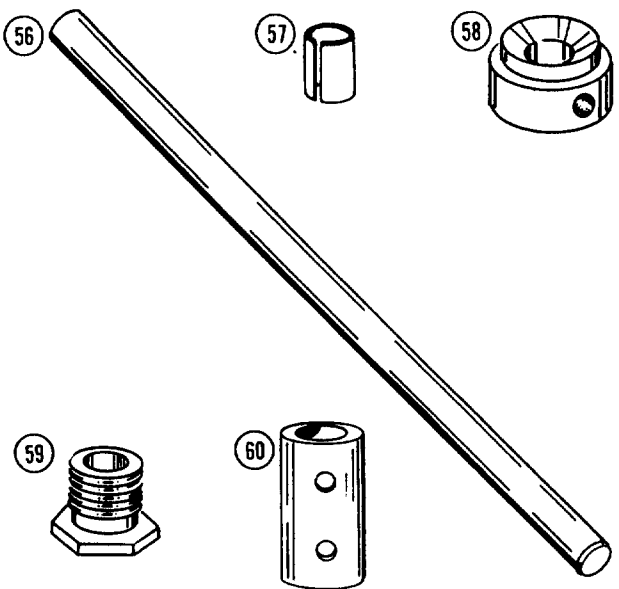

**PARTS PICTORIAL**

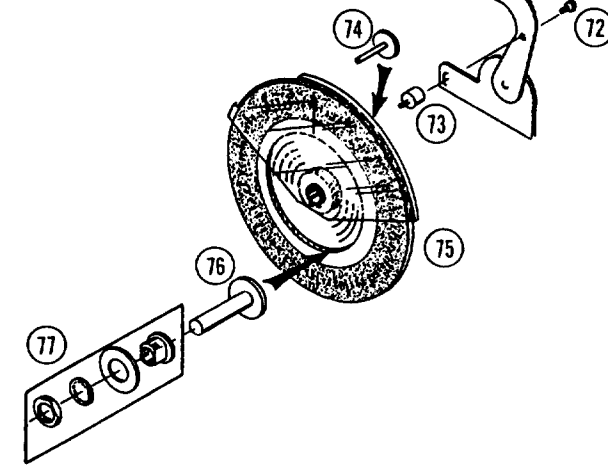
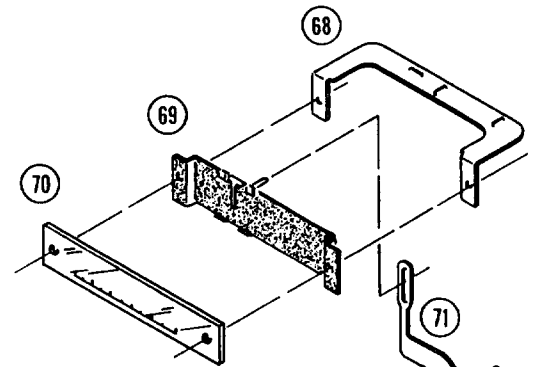
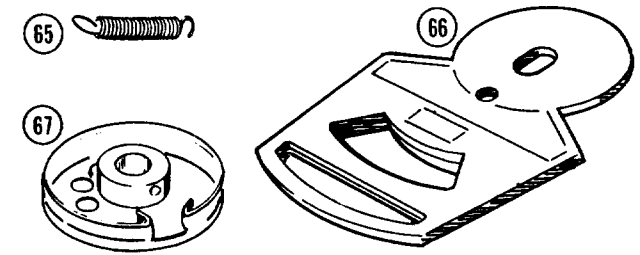

**PART NO. QUANTITY DESCRIPTION**

**METAL PARTS**

90-341	1	Cabinet
205-479	1	78 Final shield rear plate
204-653	1	79 Capacitor mounting bracket
205-478	1	80 Final shield top plate
206-277	1	81 Final shield
204-652-1	1	82 Control mounting bracket
204-9	1	83 Angle bracket
205-531-1	1	84 Crystal retaining plate
200-548-1	1	85 Chassis
204-412	1	86 Pilot lamp mounting bracket
204-560	2	87 Support rail
203-414-1	1	88 Front panel
204-654	1	89 Switch mounting bracket
206-276	1	90 Driver shield
205-87	1	91 Bottom tube socket shield
206-308	1	92 Heterodyne oscillator shield
206-309	1	93 Heterodyne oscillator cover

**TOOLS**

205-254	1	94 Alignment tool blade
490-1	1	95 Alignment tool
490-23	1	96 #4 allen wrench
490-14	1	#6 allen wrench
490-85	1	#8 allen wrench
490-19	1	97 1/4" open end wrench

**PARTS PICTORIAL**

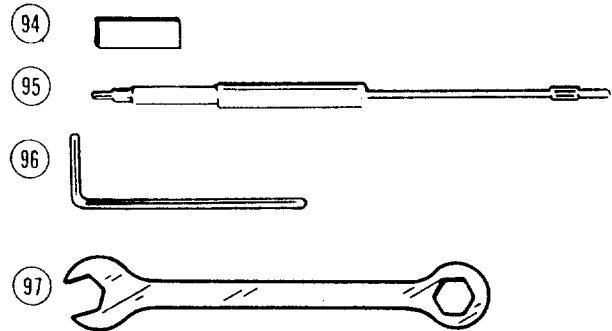

**PARTS PICTORIAL**

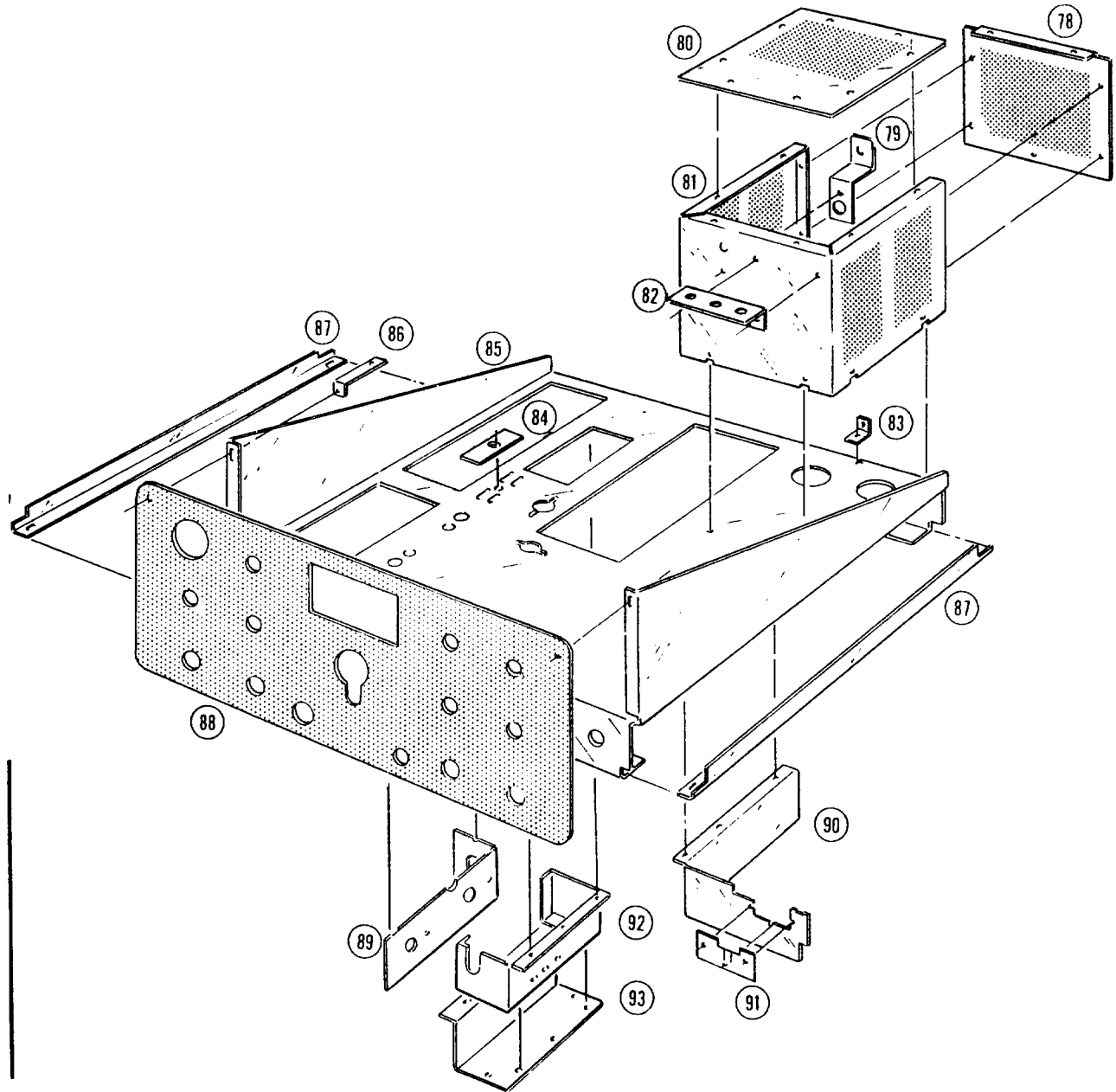



**PART NO. QUANTITY DESCRIPTION**

**HARDWARE**

**#3 Hardware**

250-49	13	98	3-48 x 1/4" screw
250-172	40	99	3-48 x 3/8" screw
250-251	2	100	3-48 x 3/8" flat head screw
250-133	4	101	3-48 x 7/16" screw
252-1	63	102	3-48 nut
254-7	110	103	#3 lockwasher

**#4 Hardware**

250-156	2	104	4-40 x 1/8" setscrew
252-15	2	105	4-40 x 3/16" nut
254-9	2	106	#4 lockwasher

**#6 Hardware**

250-230	4	107	6-32 x 3/16" setscrew
250-56	45	108	6-32 x 1/4" screw
250-170	19	109	#6 x 1/4" sheet metal screw
250-32	4	110	6-32 x 3/8" flat head screw
250-218	2	111	6-32 x 3/8" phillips head screw
250-89	6	112	6-32 x 3/8" screw
250-26	2	113	6-32 x 5/8" screw
250-13	2	114	6-32 x 1" screw
250-40	3	115	6-32 x 1-1/2" screw
252-3	70	116	6-32 nut
252-23	1	117	6-32 knurled nut
253-1	1	118	#6 fiber flat washer
254-1	85	119	#6 lockwasher

**#8 Hardware**

250-260	2	120	8-32 x 1/4" oval head screw
250-93	16	121	8-32 x 1/4" setscrew
250-22	1	122	8-32 x 7/16" setscrew
250-72	1	123	8-32 x 3/4" screw
252-4	1	124	8-32 nut
252-28	1	125	8-32 knurled nut
253-45	2	126	#8 flat washer
254-2	1	127	#8 lockwasher

**PART NO. QUANTITY DESCRIPTION**

**1/4" Control Hardware**

252-39	3	1281	4-32 nut
254-14	1	1291	1/4" lockwasher
259-12	4	1301	1/4" solder lug

**3/8" Control Hardware**

252-7	14	131	3/8-32 nut
253-10	14	132	3/8" flat washer
254-5	9	133	3/8" lockwasher
259-10	6	134	3/8" solder lug

**Other Hardware**

207-19	1	135	Cable clamp
250-143	1	136	6-32 x 1/2" threaded stud
251-1	9	137	6-32 spade bolt
253-60	6	138	#6 flat washer
254-15	1	139	5/16" lockwasher
255-2	6	140	3/16" long spacer
255-50	2	141	19/32" long spacer
259-6	5	142	Small #6 solder lug
259-1	6	143	Large #6 solder lug
260-39	2	144	Anode clip (appearance may vary)
435-1	1	145	11-pin socket retaining ring

**PARTS PICTORIAL**

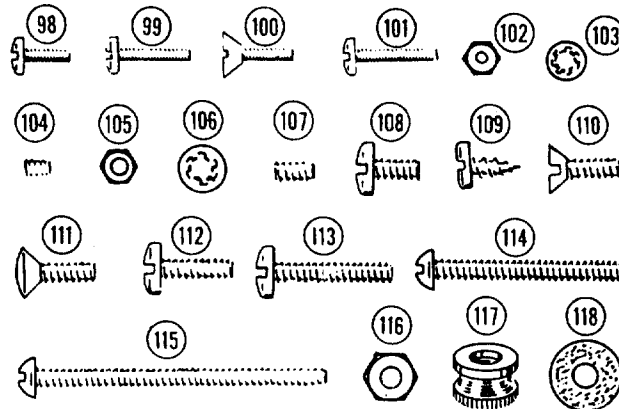

**PARTS PICTORIAL**

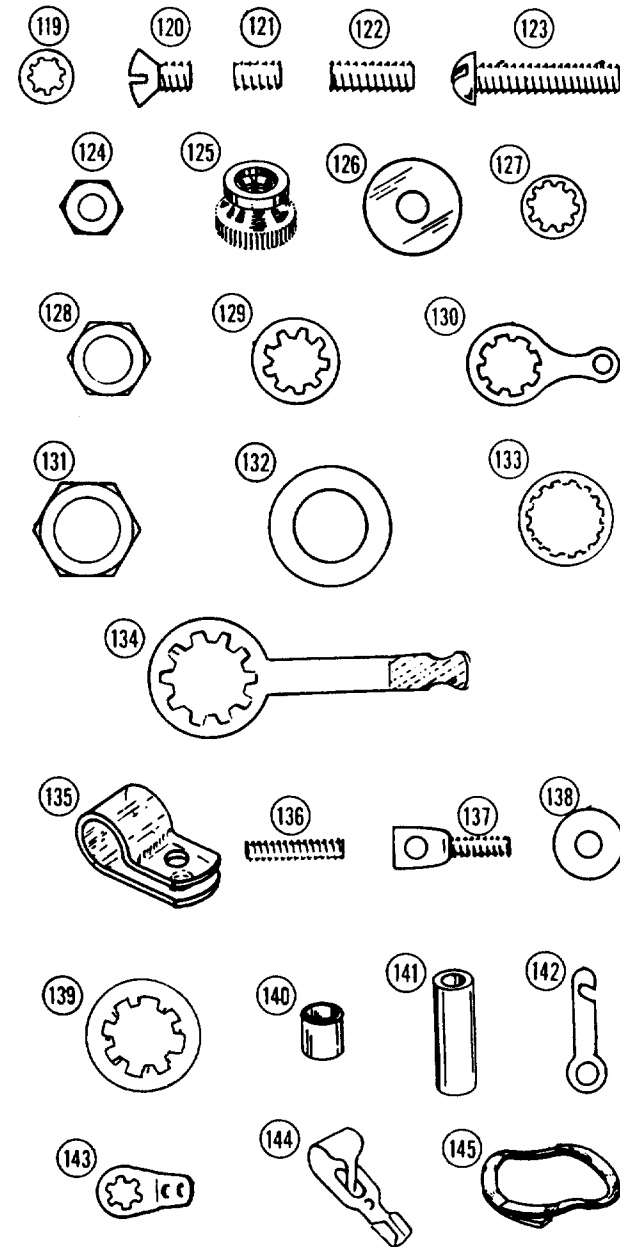

PART NO.	QUANTITY	DESCRIPTION
----------	----------	-------------

PARTS PICTORIAL

PARTS PICTORIAL

**MISCELLANEOUS**

69-17	1	146 SPDT relay
69-21	1	4PDT and 3PST relay
74-6	1	Roll tape
100-591	1	147 Harmonic filter
110-28	1	LMO (linear master oscillator)
255-59	2	148 Foot spacer
261-9	4	149 Rubber foot
266-19	1	150 180 degree rotational stop
352-13	1	Silicone grease pod
390-147	1	High voltage label
391-29	1	SB-110 nameplate
407-101	1	Meter
440-1	1	151 11-pin socket cap
	1	Parts Order Form
	1	Blue and white label

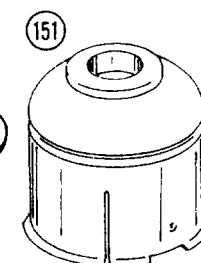
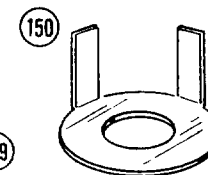
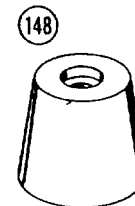
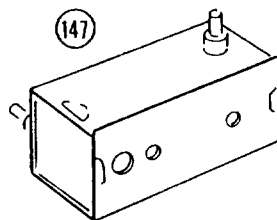
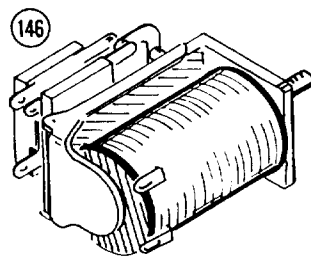

## CHASSIS ASSEMBLY

Because the chassis is quite large, it has been divided into sections to simplify assembly. Note in Figure 3-9, the chassis has been divided into six sections, on the top and bottom, by the imaginary lines. Besides the Figure 3-9 that folds out from Page 150, there is also a larger loose one that can be placed on a wall in your work area. Use this Figure as a quick reference throughout the assembly of the Transceiver.

Each section of the chassis has its part locations identified by a different group of letters. For example, the upper left hand section on the bottom of the chassis is lettered AA, AB, AC, etc. The lower right hand section uses letters beginning with F.

The heading at the beginning of each assembly page describes the operation to be performed (Parts Mounting, Wiring, etc.), and the chassis section where it is to be performed. Refer to Figure 3-9 to locate these chassis sections.

In the wiring portions of this Manual, the steps will not name the part (tube socket, terminal strip, etc.) to be wired to; instead a line will lead directly from the step to the part being installed.

Only the location and lug number of the part being wired to will be called out in a step. For example, a step might read "3-1/2" brn wire from AD6 (S-1) to AE7 (NS)." The letters AD and AE refer to locations on the chassis. The numbers 6 and 7 represent the lug numbers of the parts at these locations.

Lockwashers and nuts will be used with most screws when mounting parts, unless it is stated otherwise in a step. Consequently, only the size and type of hardware to be used will generally be called out. For example, the phrase "Use 3-48 x 1/4" hardware" means to use a 3-48 x 1/4" screw, one or more #3 lockwashers, and a 3-48 nut. Refer to the drawing accompanying the step for the proper installation of the hardware and the correct number of lockwashers. Be sure to use the flat head and oval head screws only when they are called for in a step.

**PARTS MOUNTING-SECTION A**

( ) Phono socket with 2-lug miniature terminal strip at AC. Use 6-32 x 1/4" hardware.

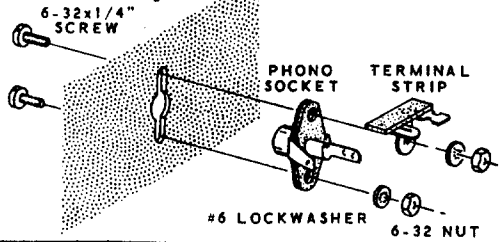

( ) Phono socket at AA. Use 6-32 x 1/4" hardware. Position the socket as shown.

( ) 8-pin tube sockets at AD and AF. Use 6-32 x 1/4" hardware. Position the keyway of each socket as shown.

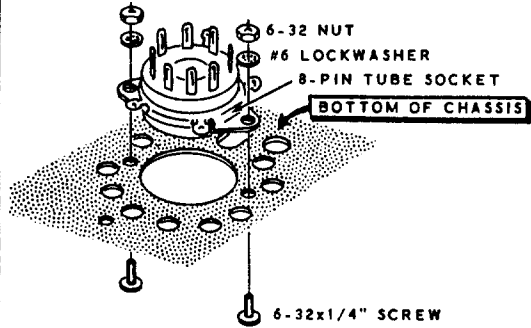

( ) 9-pin miniature tube socket at AL. Use 3-48 x 1/4" hardware. Position the wide space as indicated by the arrow.

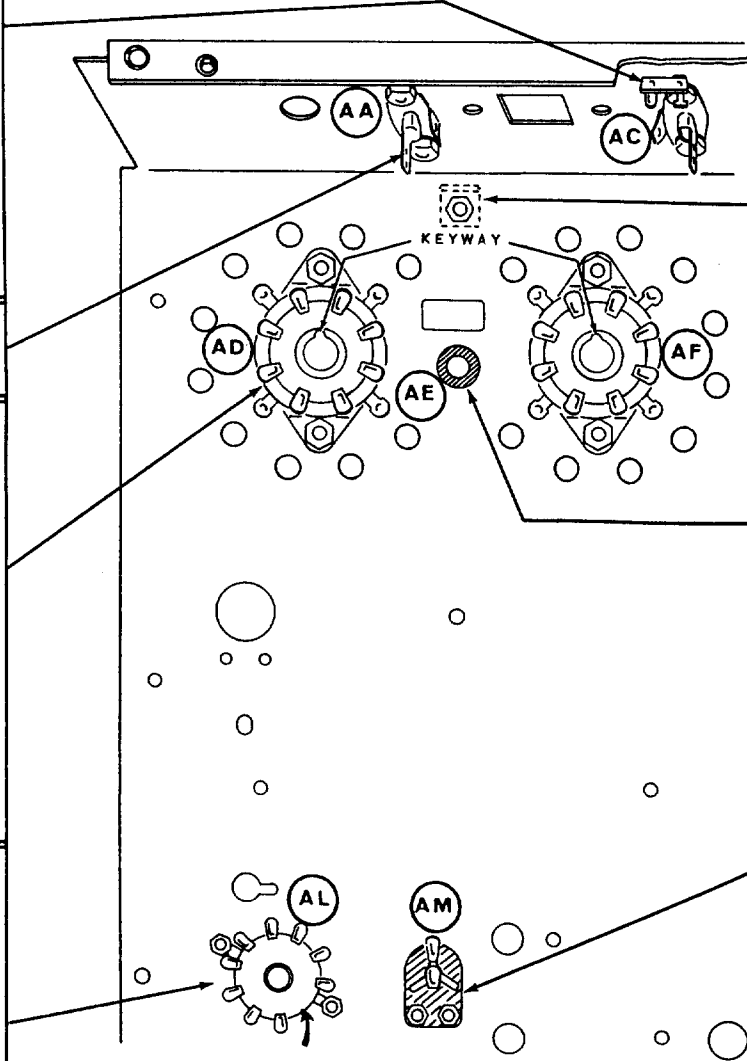
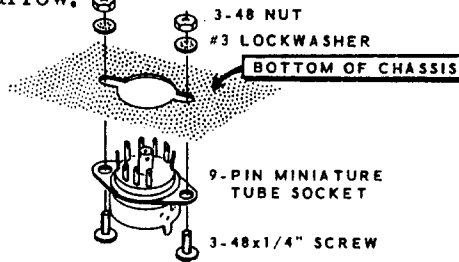

( ) Small angle bracket on top of the chassis. Use 6-32 x 1/4" hardware. Position as shown. Use the unthreaded hole.

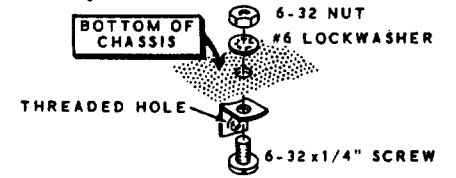

( ) 5/16" rubber grommet at AE.

( ) 1.5-7  $\mu$ f trimmer, #31-30, on the bottom of the chassis at AM. Use 3-48 x 1/4" hardware. Center the trimmer in the chassis opening.

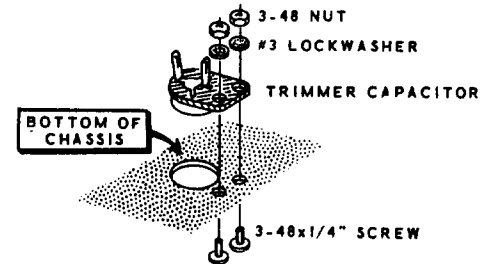

**PICTORIAL 2-1**

Parts Mounting-Section A-Continued

- ( ) Bend pins 3, 4, and 9 of tube socket AL against the center post as shown.

BEND TUBE SOCKET LUGS AGAINST CENTER POST AS SHOWN.

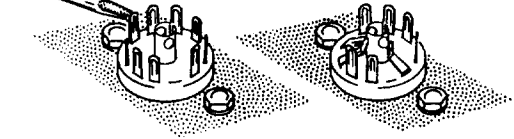

Install the following parts on the driver shield:

- ( ) Bottom tube socket shield, Use 3-48 x 1/4" hardware.

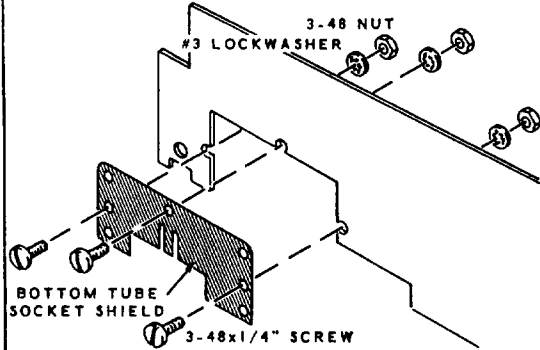

- ( ) 6-32 spade bolt, Use 6-32 x 1/4" hardware. Position the offset as shown.

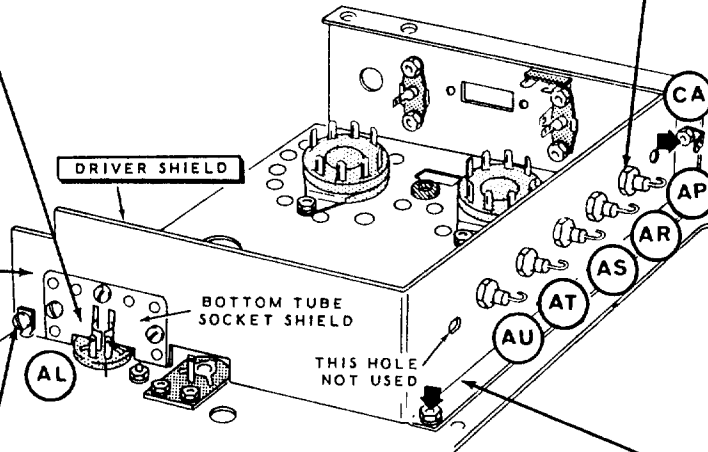
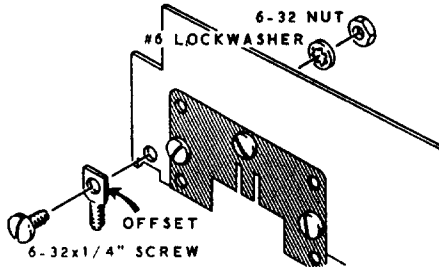

PICTORIAL 2-2

- ( ) Small .001  $\mu$ fd 500 V feedthrough (brn-blk-red) at AP, AR, AS, AT, and AU. Position as shown. Use care in mounting, as these capacitors can be damaged easily.

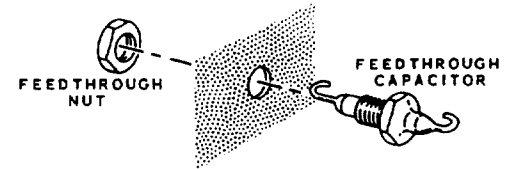

- ( ) Driver shield to the chassis, with a large #6 solder lug at CA. Use 6-32 x 1/4" hardware at the locations indicated by the arrows. Use a #6 lock-washer and a 6-32 nut on the spade bolt. Position the bottom tube shield in tube socket AL as shown.

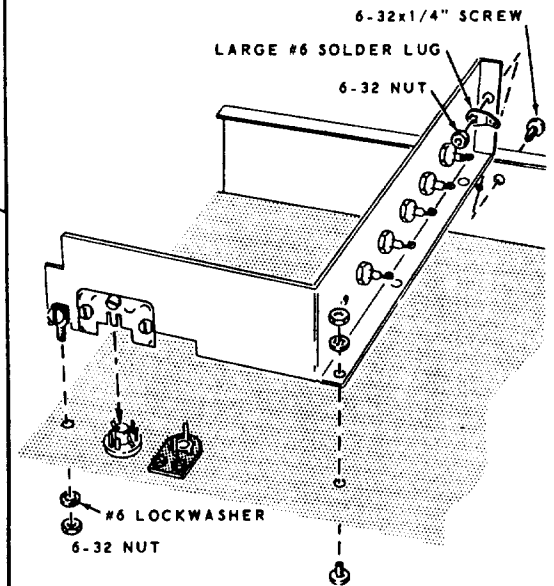

Parts Mounting-Section A-Continued

( ) 3-12  $\mu\text{f}$  trimmer, #31-31, on top of the chassis at AG. Use 3-48 x 1/4" hardware. Center the trimmer in the chassis opening.

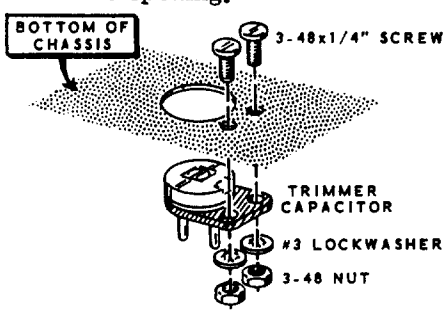

Labels: BOTTOM OF CHASSIS, 3-48x1/4" SCREW, TRIMMER CAPACITOR, #3 LOCKWASHER, 3-48 NUT

( ) 360  $\mu\text{f}$  feedthrough (org-blu-brn) at AJ, with a 1/4" control solder lug on top of the chassis. Position and bend the solder lug as shown.

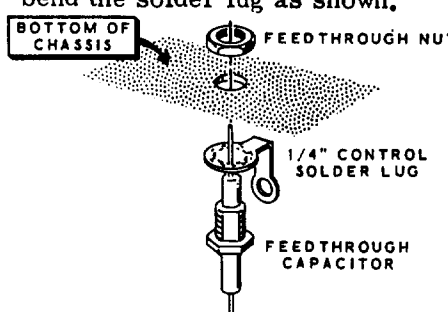

Labels: BOTTOM OF CHASSIS, FEEDTHROUGH NUT, 1/4" CONTROL SOLDER LUG, FEEDTHROUGH CAPACITOR

( ) Coil #40-530 at AK. Position the locating tab as shown. Press on the coil until the locking tabs snap into place.

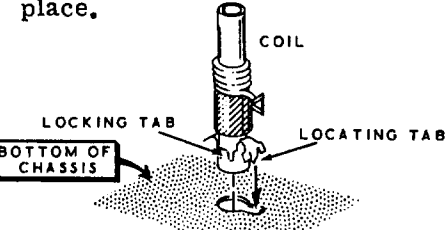

Labels: COIL, LOCKING TAB, LOCATING TAB, BOTTOM OF CHASSIS

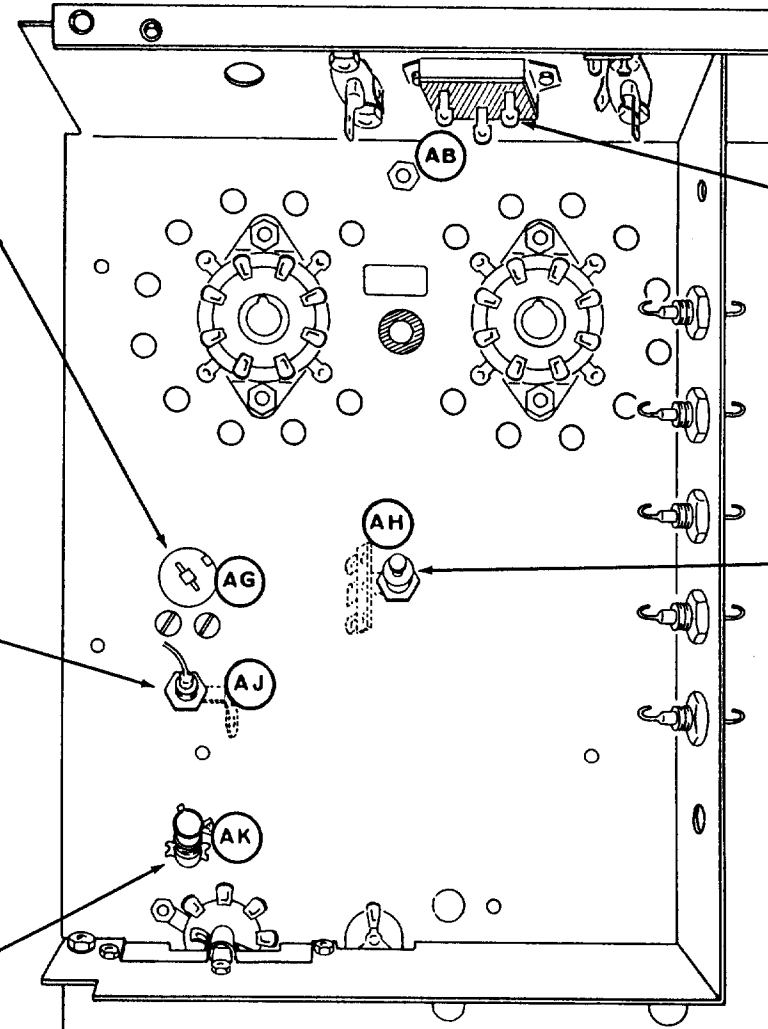

( ) SPDT slide switch at AB. Use 6-32 x 1/4" screws. Position the switch as shown.

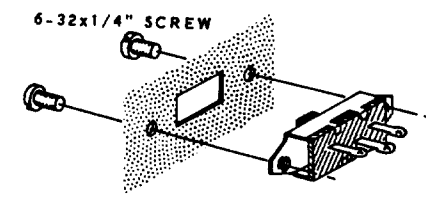

Label: 6-32x1/4" SCREW

( ) Small ceramic standoff at AH, with a 3-lug miniature terminal strip on top of the chassis. Use #6 lockwashers and a 6-32 nut. Position the terminal strip as shown.

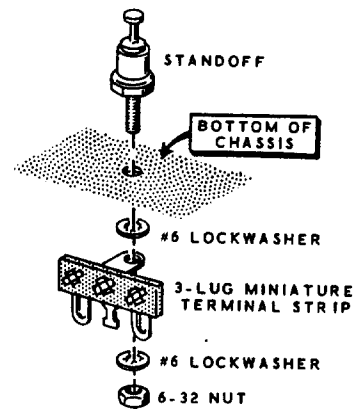

Labels: STANDOFF, BOTTOM OF CHASSIS, #6 LOCKWASHER, 3-LUG MINIATURE TERMINAL STRIP, #6 LOCKWASHER, 6-32 NUT

PICTORIAL 2-3

**PARTS MOUNTING-SECTION B**

( ) Transmitter mixer circuit board #85-118, with a 2-lug miniature terminal strip at BA. Tape a screw in each mounting hole from the lettered side of the circuit board. Remove the tape after mounting. Use 3-48 x 3/8" hardware. Be sure to use lockwashers between the circuit board and chassis.

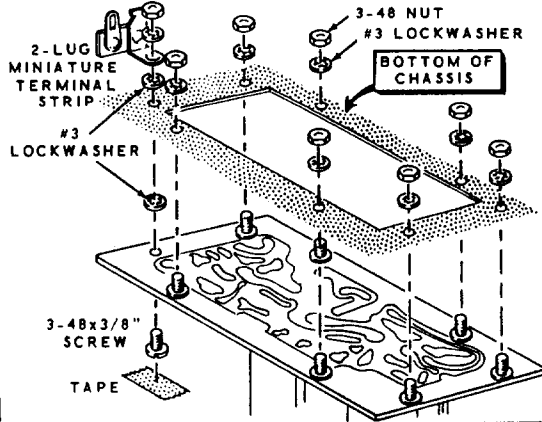

( ) 10 K $\Omega$  tab mount control, #10-57, on top of the chassis. Bend the mounting tabs as shown.

1. INSERT CONTROL TABS
2. BEND TABS OVER

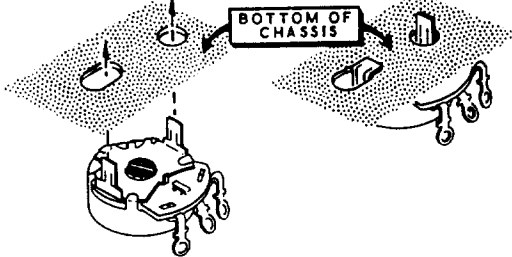

( ) 2000  $\Omega$  tab mount control, #10-52, on top of the chassis.

( ) 500 K $\Omega$  tab mount control, #10-60, on top of the chassis.

( ) 500 K $\Omega$  tab mount control, #10-60, on top of the chassis.

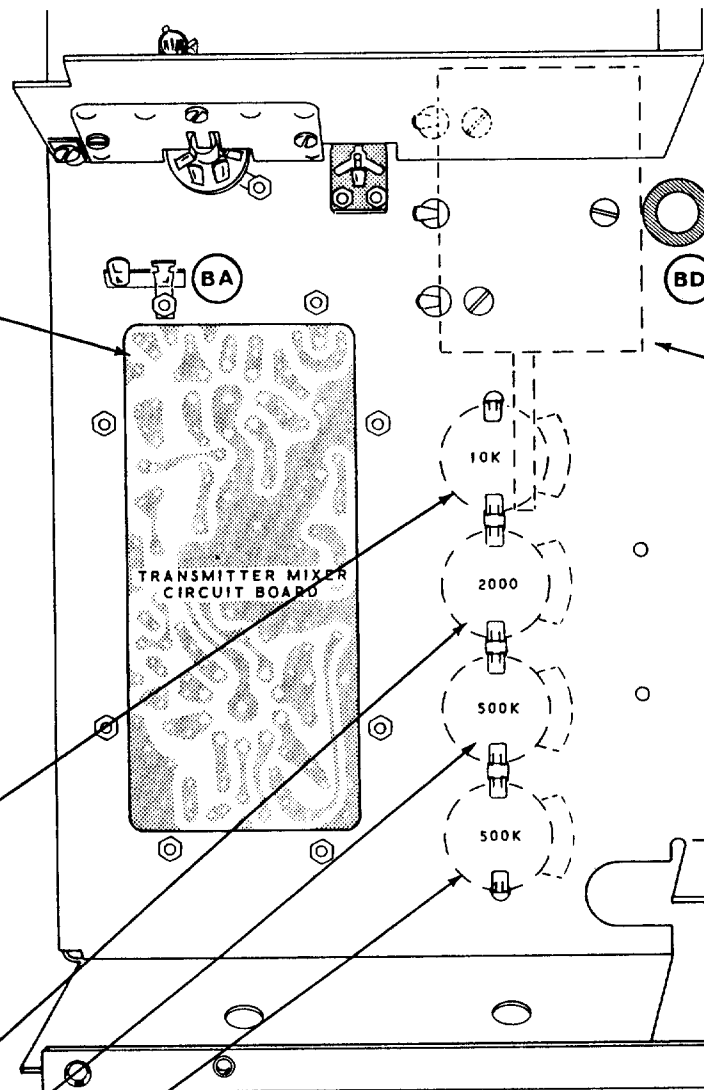

( ) 1/2" rubber grommet at BD.

**CAUTION:** Keep the plates of all variable capacitors fully closed during assembly to prevent damage to the capacitors.

( ) 15  $\mu\mu\text{f}$  3-section variable capacitor, #26-106, on the top of the chassis. Use 6-32 x 3/8" screws, #6 lockwashers and 3/16" long spacers. Bend the proper three lugs down so they will fit through the chassis holes. Bend the other three lugs up.

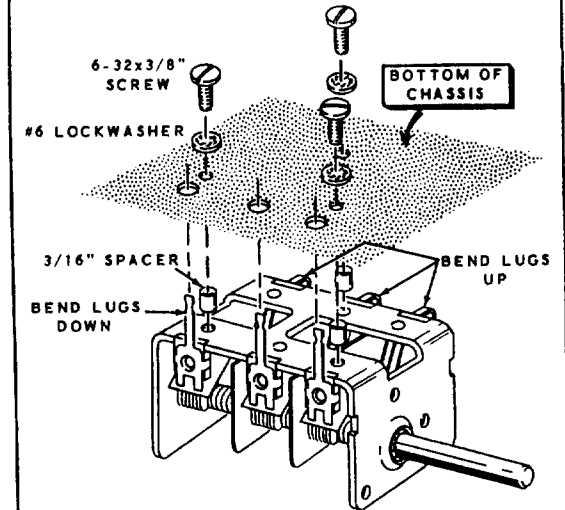

**PICTORIAL 2-4**

**PARTS MOUNTING-SECTIONS C AND E**

( ) Ground bolt at CB. Use 8-32 x 3/4" hardware with #8 flat washers and an 8-32 knurled nut.

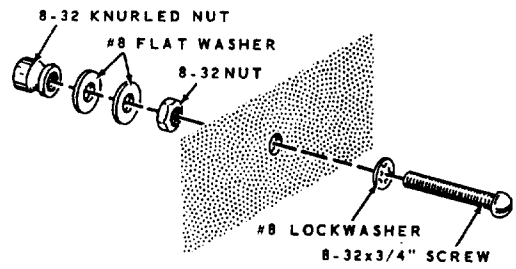

( ) 11-pin plug, #438-29, at CC. Use an 11-pin plug retaining ring. Position pin 1 as shown.

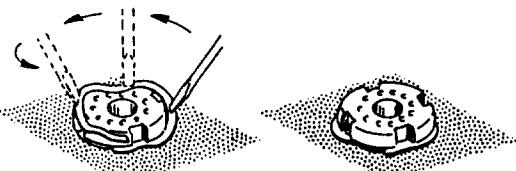

HOLD THE PLUG IN THE CHASSIS HOLE AND PLACE ONE END OF THE RING INTO THE GROOVE OF THE PLUG. USING A SCREWDRIVER, PRESS THE RING INTO THE GROOVE AROUND THE PLUG.

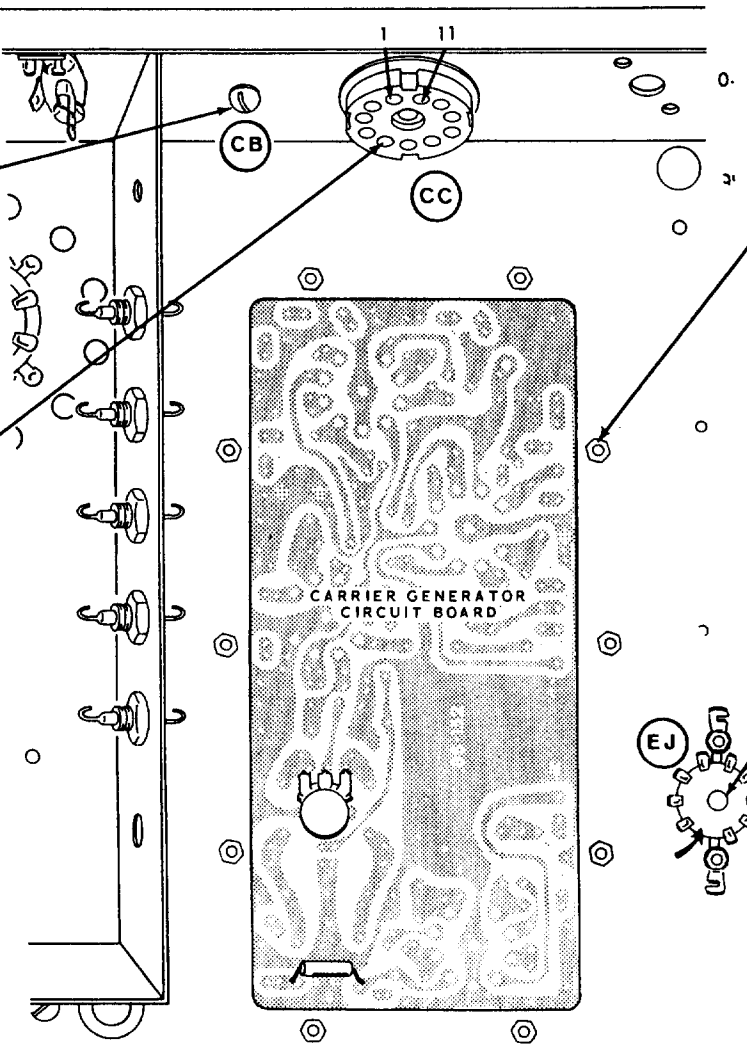

( ) Carrier generator circuit board, #85-152. Use 3-48 x 3/8" hardware. Tape the screws to the lettered side of the circuit board as before. Remove the tape after the circuit board is mounted.

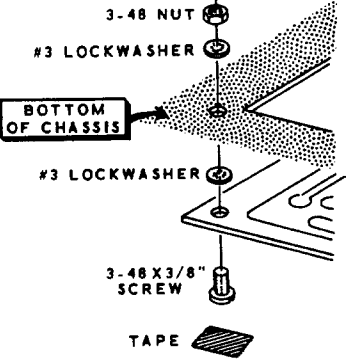

( ) 9-pin miniature tube socket at EJ. Use 3-48 x 1/4" hardware with small #6 solder lugs. Position the wide space of the tube socket as indicated by the arrow, and position the solder lugs as shown. Bend both solder lugs straight up.

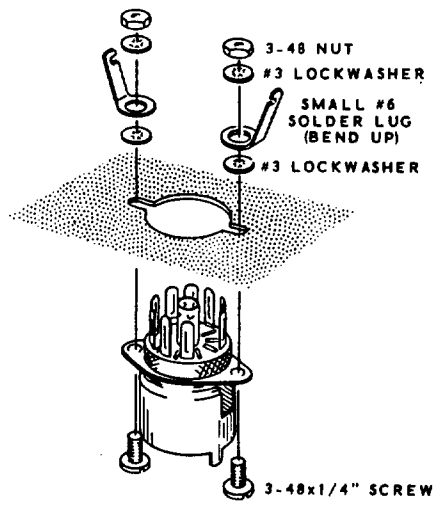

**PICTORIAL 2-5**

**PARTS MOUNTING-SECTION D**

- ( ) 19/32" long spacers. Use 6-32 x 1" hardware.

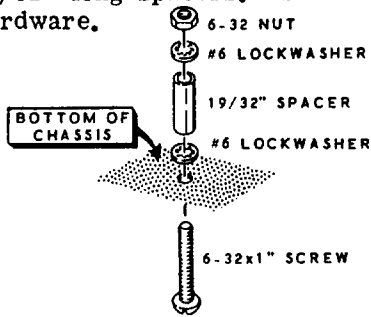

- ( ) Remove the tube shield and tube from the LMO (#110-28).
- ( ) Plastic cable clamp at location MF. Use the LMO screw. Position the cable clamp as shown.
- ( ) LMO on the top of the chassis with a 3-lug miniature terminal strip at DC on the bottom of the chassis. Use #6 lockwashers and 6-32 nuts. Center the mounting bolts in the chassis slots. Tighten the nuts only enough to hold the LMO in place.

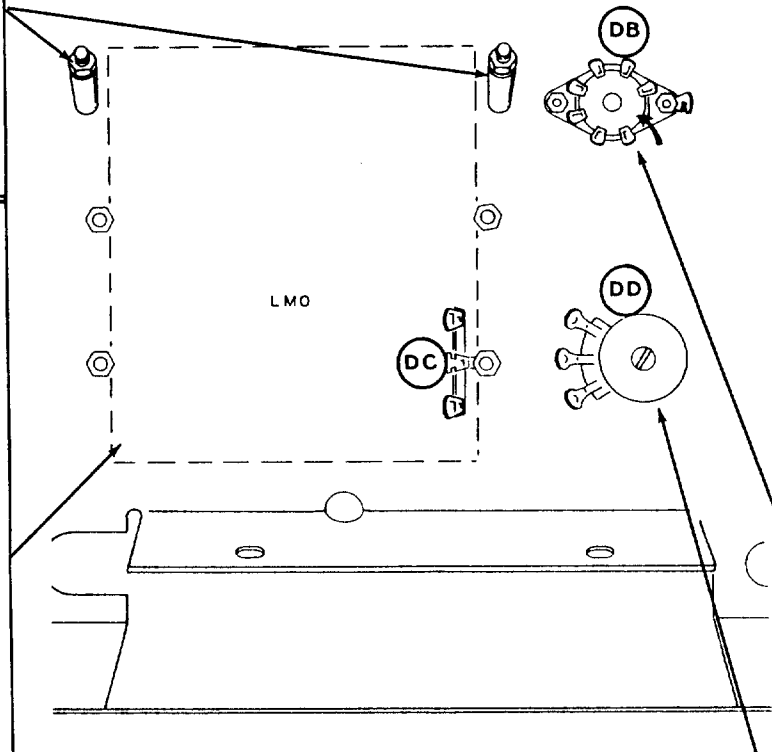
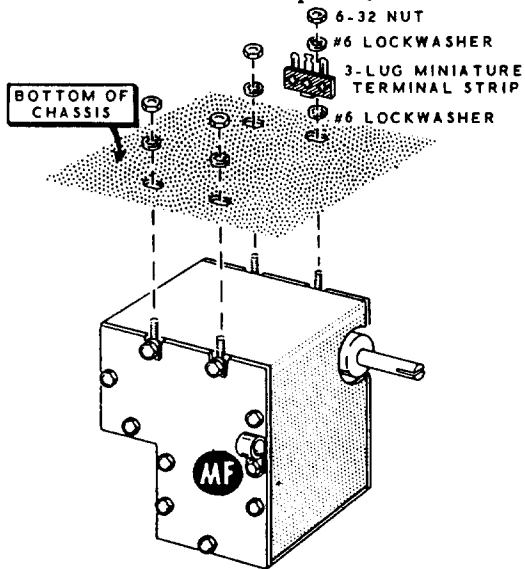

**PICTORIAL 2-6**

- ( ) Slide the circular dial, #100-449, onto the shaft of the LMO. Place a ruler or other straight edge along the front of the chassis. Adjust the LMO so the circular dial is parallel to the front edge of the chassis. Tighten the nuts that secure the LMO to the chassis. Remove the circular dial. Keep the LMO mounting bolts as near the center of the chassis slots as possible.

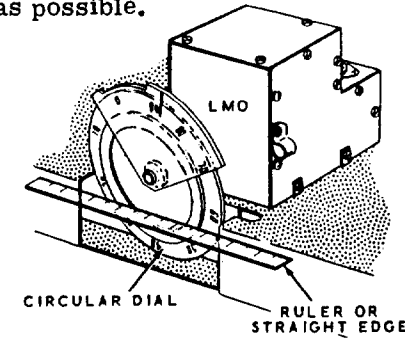

- ( ) 7-pin miniature tube socket at DB. Use 3-48 x 1/4" hardware with a small #6 solder lug as shown. Position the wide space of the socket as indicated by the arrow. Position and bend the solder lug as shown.

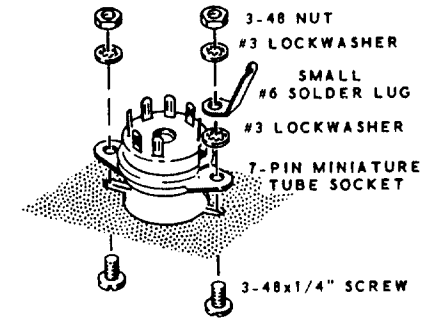

- ( ) 10 KΩ tab mount control #10-57 at DD. Position the control as shown. Bend the tabs against the chassis as before.



## PARTS MOUNTING-SECTION E

( ) 5/16" rubber grommet at EB.

( ) 5-lug terminal strip at EG. Use 6-32 x 1/4" hardware. Position the terminal strip as shown.

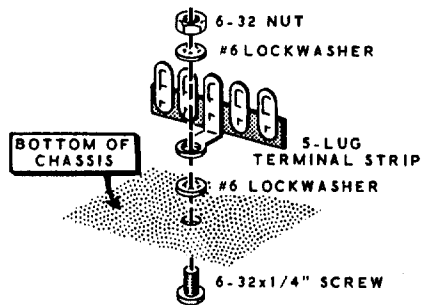

( ) Oscillator coil circuit board #85-116. Use 3-48 x 3/8" hardware as before. Be sure to use lockwashers between the circuit board and the chassis. Refer to Figure 3-9 (top of chassis) for proper positioning of this circuit board. The white coil forms should be toward the front of the chassis.

( ) Crystal sockets on top of the chassis at EL, EM, EN, and EP. Use 3-48 x 7/16" hardware. Do not overtighten the hardware.

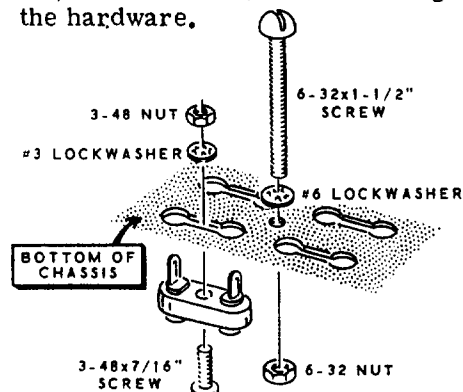

( ) 6-32 x 1-1/2" hardware at EY.

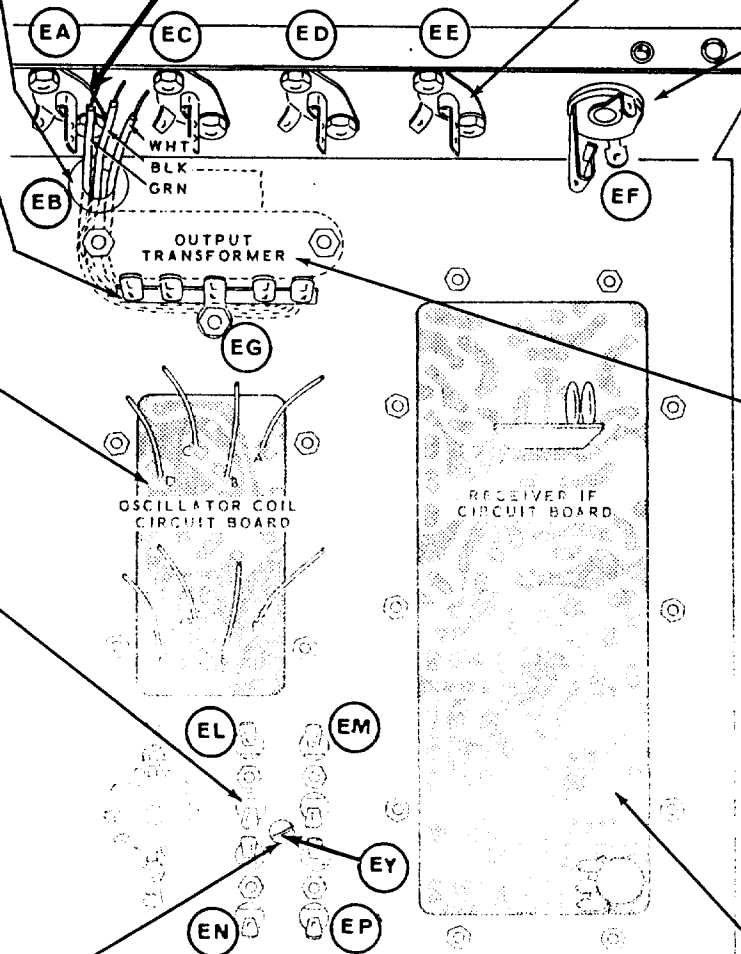
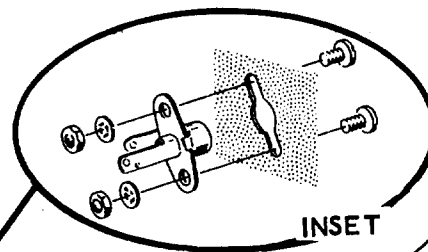

PICTORIAL 2-7

( ) Phono sockets at EA, EC, ED, and EE. Use 6-32 x 1/4" hardware. Position each socket as shown.

( ) 2-lug phone jack at EF. Use a 3/8" control lockwasher, 3/8" control flat washer, and a 3/8-32 control nut. Position the jack as shown.

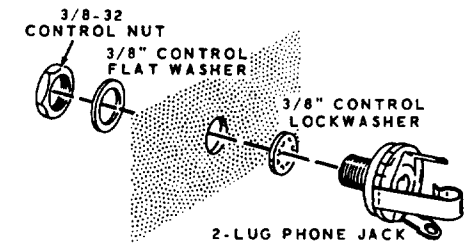

( ) Cut the leads of the output transformer, #51-123, as shown. Strip 1/4" of insulation from the end of each lead. Melt a small amount of solder on each of the exposed lead ends.

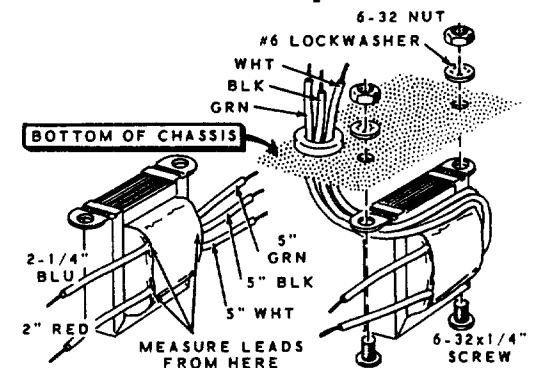

( ) Install the transformer on the top of the chassis. Use 6-32 x 1/4" hardware. Pass the wht, blk, and grn leads through grommet EB to be connected later.

( ) Receiver IF circuit board, #85-115-2. Use 3-48 x 3/8" hardware as before.

**PARTS MOUNTING-SECTION F**

( ) Receiver RF circuit board, #85-114.  
Use 3-48 x 3/8" hardware as before.

( ) 15  $\mu$ pf 3-section variable capacitor, #26-106, on the top of the chassis. Use 6-32 x 3/8" screws, #6 lock-washers, and 3/16" long spacers. Bend all six lugs up as shown.

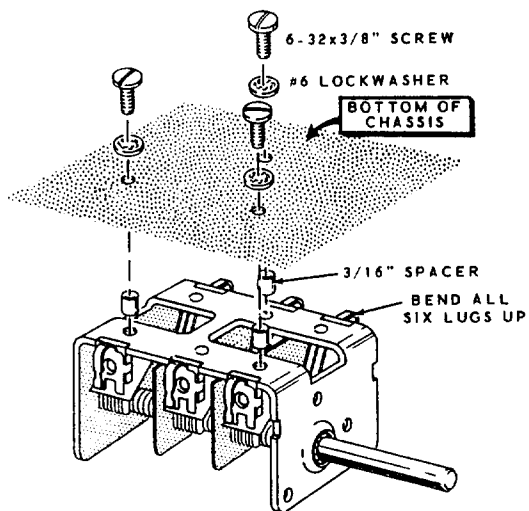

( ) 1/2" rubber grommet at FG.

( ) Threaded bushing at FH. Use a 3/8" control lockwasher, a 3/8" control flat washer, and a 3/8-32 control nut.

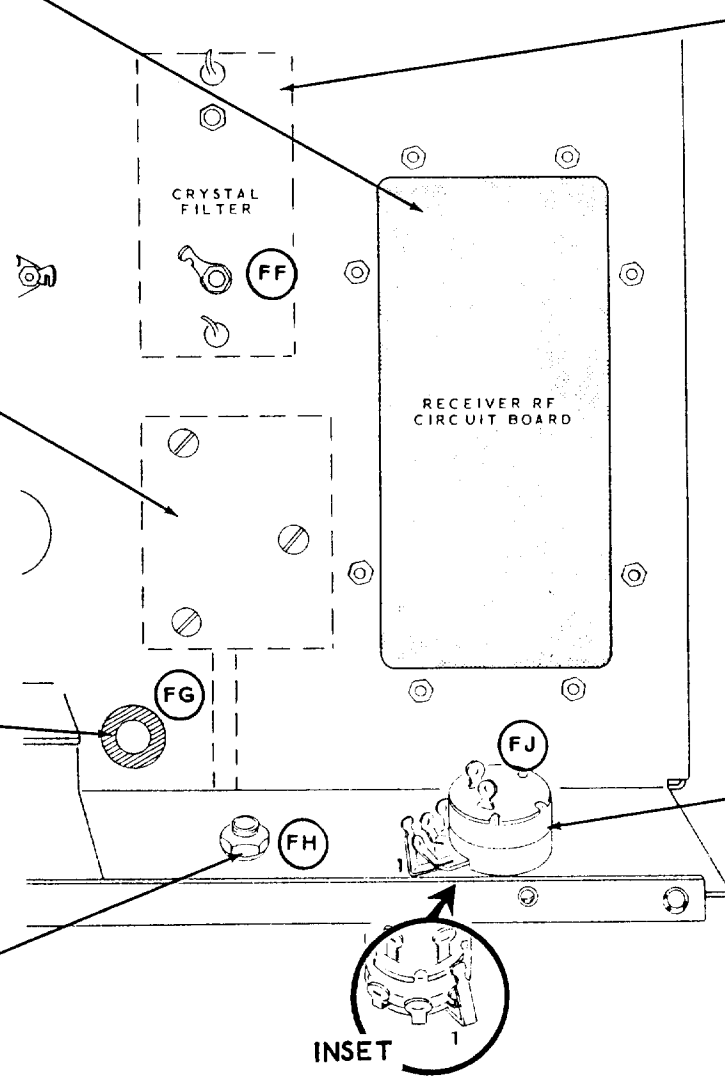
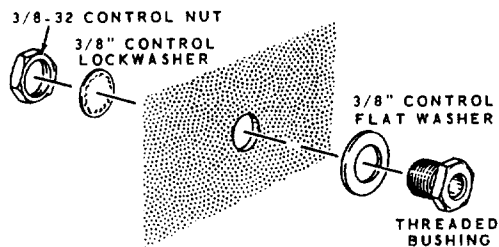

PICTORIAL 2-8

( ) 3395 kc crystal filter, #404-283, on top of the chassis. Use a #4 lock-washer and 6-32 nuts, with a small #6 solder lug at FF. The filter may be installed either way.

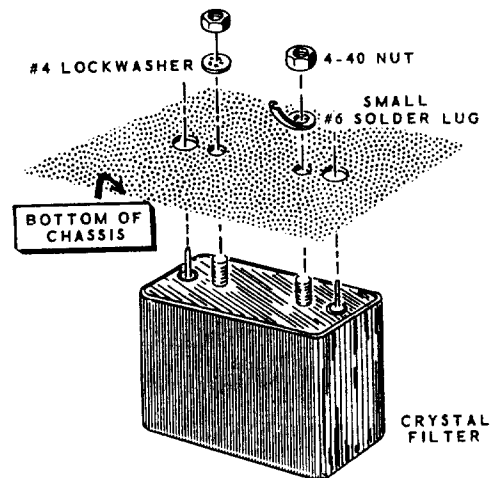

( ) 500 K $\Omega$  control with SPST push-pull switch, #19-66, at FJ. Use a 3/8" control solder lug, a 3/8" control flat washer, and a 3/8-32 nut. Position the control as shown. Bend the solder lug against lug 1 of the control.

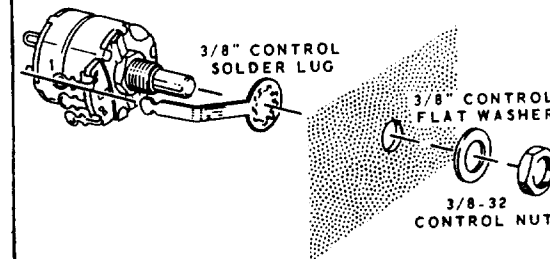

## PRELIMINARY WIRING-SECTION L

( ) 100 K $\Omega$  (brn-blk-yel) from the solder lug at LG (S-1) to LH2 (NS).

( ) Lead of LG to LH1 (S-1).

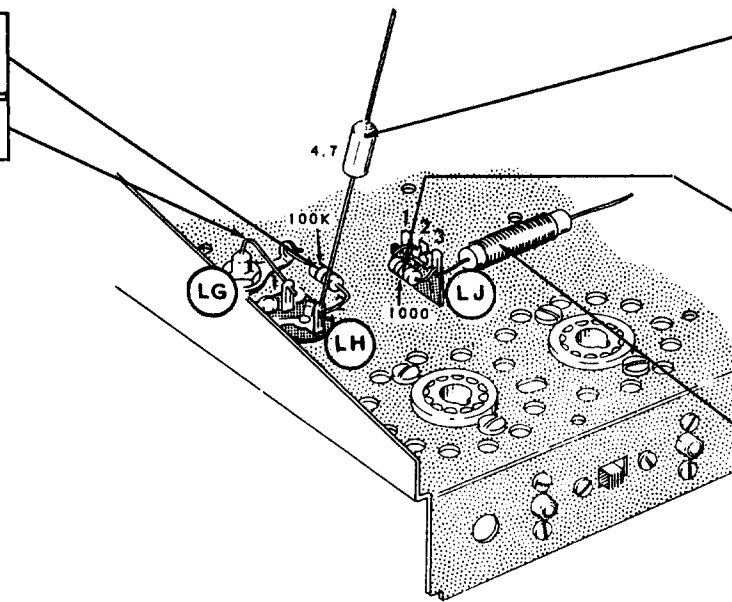

PICTORIAL 2-9

( ) 4.7  $\mu\text{f}$  tubular. One lead to LH2 (S-2). Use the full lead length. The other lead will be connected later.

NOTE: When a lead passes through a lug, as in the next step, it will be considered as two leads, one entering and one leaving the lug.

( ) 1000  $\Omega$  (brn-blk-red). One lead through LJ1 (S-2) to LJ2 (S-1). The other lead to LJ3 (NS).

( ) Choke #45-36 (red-dot). Cut one lead to 1/2" and connect it to the eyelet of LJ2 (S-1). The other lead will be connected later.

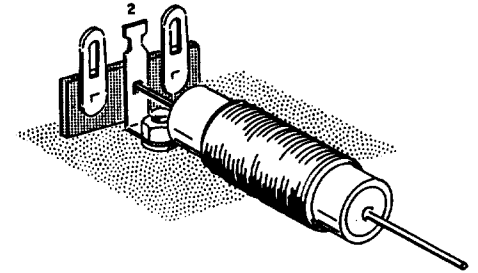

## PARTS MOUNTING-FINAL SHIELD

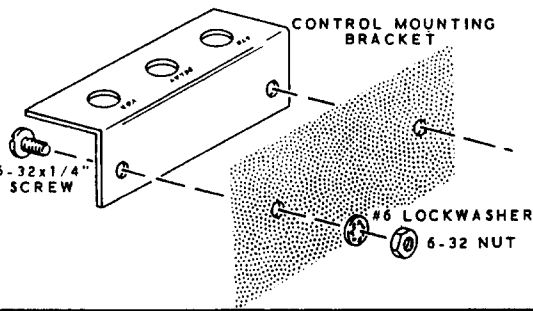
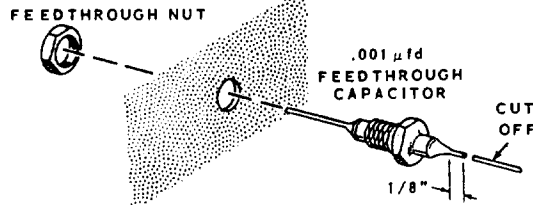
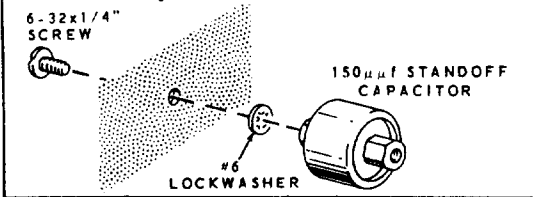
- ( ) Control mounting bracket, Use 6-32 x 1/4" hardware in only one hole. Align the other hole in the bracket with the hole in the final shield.
- 
- CONTROL MOUNTING BRACKET
- 6-32x1/4" SCREW
- #6 LOCKWASHER
- 6-32 NUT
- ( ) Large .001  $\mu$ fd 1000 V (brn-blk-red-blk) feedthrough at LB. Cut the indicated lead to 1/8".
- 
- FEEDTHROUGH NUT
- .001  $\mu$ fd FEEDTHROUGH CAPACITOR
- CUT OFF
- 1/8"
- ( ) Cut one lead of a #45-2 choke to 3/8". Form a loop in this lead as shown and connect it to LB (S-1). The other lead will be connected later.
- ( ) 150  $\mu$ fd standoff capacitor at LC. Use a 6-32 x 1/4" screw and a #6 lockwasher.
- 
- 6-32x1/4" SCREW
- 150  $\mu$ fd STANDOFF CAPACITOR
- #6 LOCKWASHER
- ( ) Small .001  $\mu$ fd 500 V (brn-blk-red) feedthrough at LD.

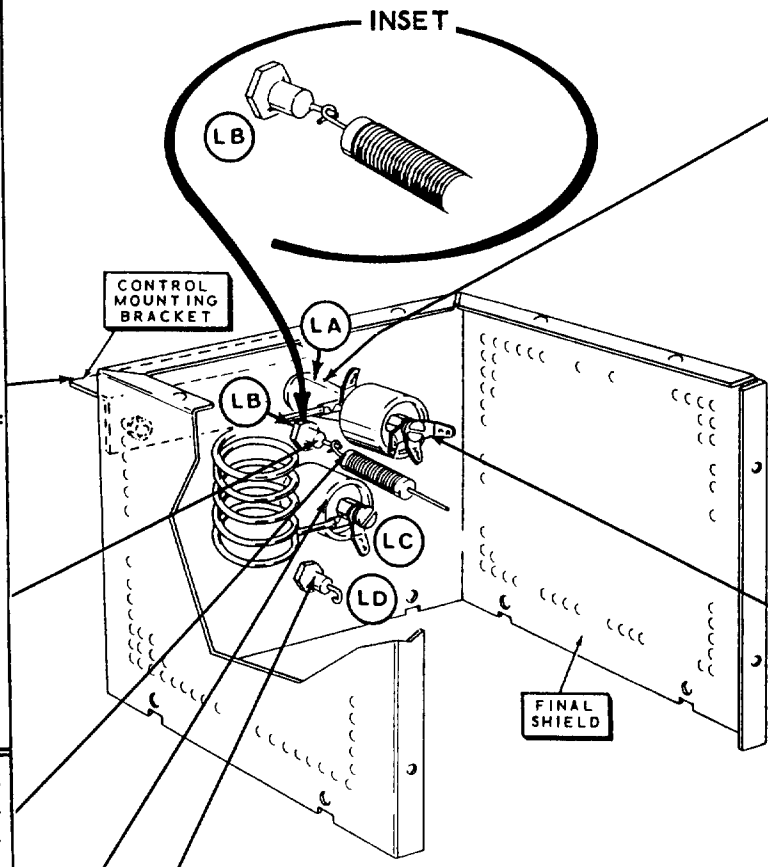

PICTORIAL 2-10

- ( ) Large ceramic standoff at LA. Use the longer screw and cork washer furnished with the standoff. Discard the other screw and the two flat washers.
- ( ) Install a #6 fiber flat washer, 6-32 x 1/2" stud, and a 6-32 nut at the small end of the standoff. Allow the stud to extend 1/4" beyond the nut.

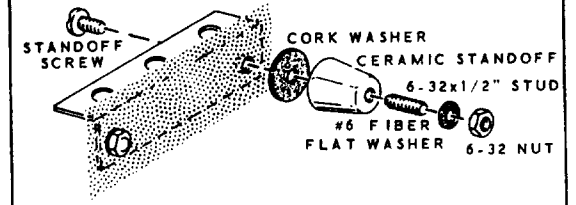

- ( ) Final tank coil #40-664, with a large #6 solder lug and a 500  $\mu$ fd standoff capacitor at LA, and with a large #6 solder lug and a 6-32 x 1/4" screw at LC.
- ( ) Install three large #6 solder lugs on standoff capacitor LA. Use a 6-32 x 1/4" screw. Position the solder lugs as shown.

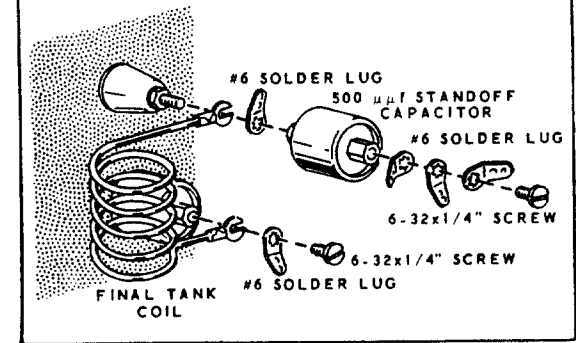

## Parts Mounting-Final Shield-Continued

( ) Free lead of choke coming from LB to LA3 (NS). Be sure the choke does not touch capacitor LA.

( ) Six spade bolts on final shield. Use 6-32 x 1/4" hardware. Position the offset as shown.

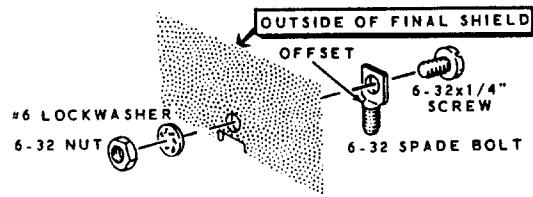

( ) 20  $\mu\text{f}$  variable capacitor #26-24 at LE on the capacitor mounting bracket. Use a 1/4" control lockwasher and the capacitor nut.

( ) Shaft coupling and split bushing on the shaft of capacitor LE. Use a 6-32 x 3/16" setscrew. Slide the shaft coupling and split bushing on the shaft until they are even with the end of the capacitor bushing.

( ) Place another split bushing in the open end of the shaft coupling. Hold the bushing in place with a 6-32 x 3/16" setscrew.

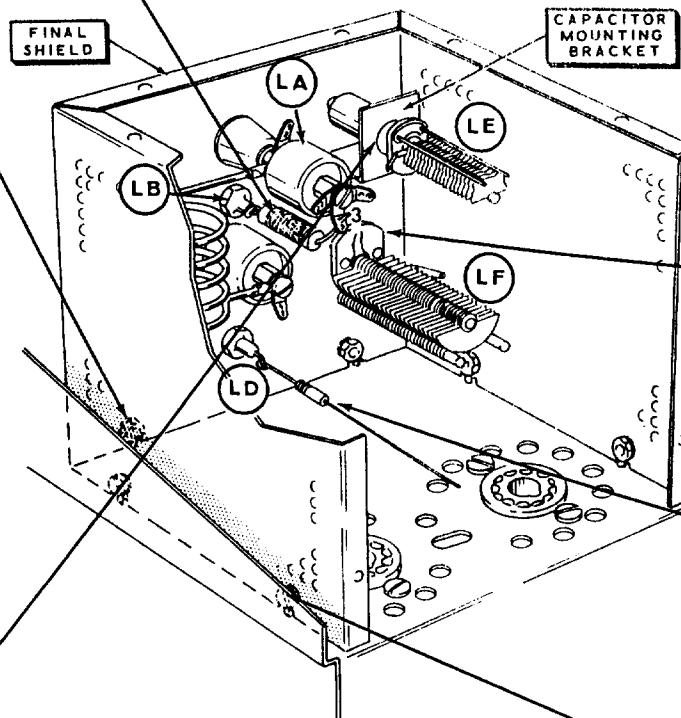
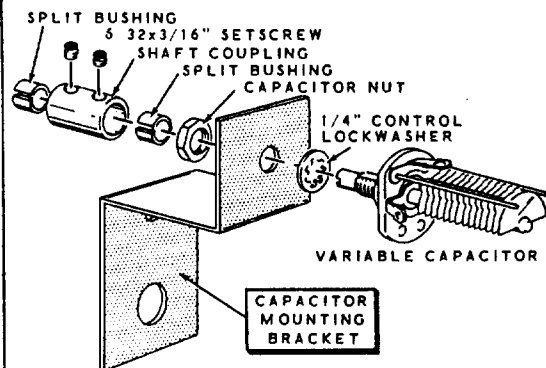

PICTORIAL 2-11

( ) Capacitor mounting bracket to the final shield. Use 6-32 x 1/4" hardware.

( ) 140  $\mu\text{f}$  variable capacitor, #26-105, at LF. Use a 5/16" lockwasher, and the capacitor flat washer and nut.

( ) Dial pulley with 1/4" hole on the shaft of capacitor LF. Use an 8-32 x 1/4" setscrew. Position the pulley as shown, with the capacitor plates fully closed. The pulley should be 1/16" from the end of the shaft.

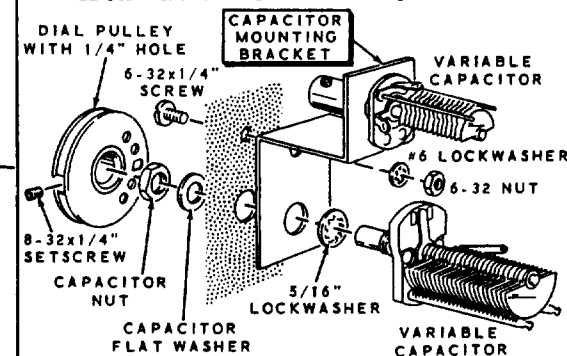

( ) Germanium diode #56-26 (brn-wht-brn). Cut the cathode lead (banded end) to 3/4" and connect it to LD (S-1). The other lead will be connected later.

( ) Final shield to chassis. Use six #6 lockwashers and six 6-32 nuts.

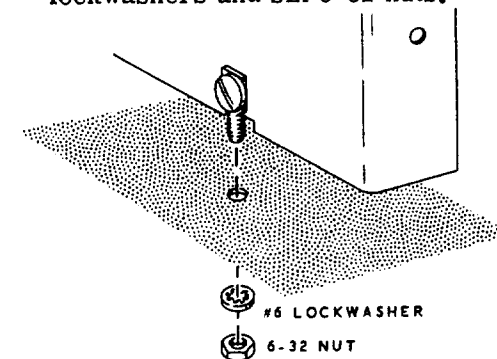

## WIRE HARNESS PREPARATION

( ) Locate the wire harness, #134-134, and form it to shape as shown. Position the wires from each BO (break-out) as shown.

( ) Remove 3/4" of insulation from the end of each of the wires at BO#8.

NOTE: The wires cut from the harness in the next three steps are to be saved and used later, when a step calls for that color wire. After the wires are cut, remove 1/4" of insulation from each of the new wire ends of the harness.

( ) At BO#7, cut off the long red and brn wires even with the end of the yel wire.

( ) At BO#14, cut off both viol wires even with the end of the yel wire.

( ) Also at BO#14, cut off the long gry and blk wires even with the end of the short gry wire.

( ) Pass a 1/2" rubber grommet over BO#17 and BO#16 and position it on the harness as shown.

( ) Install the wire harness in the bottom of the chassis as shown in Figure 3-9. The harness should be down on the chassis, except at the right rear corner and right side, where it is positioned even with the bottom edge of the chassis. Fit the rubber grommet at BO#16 in the slot at BG. Pass the wires from BO#6 through grommet BD and along the front of the final shield, and pass the wires from BO#15 through grommet FG.

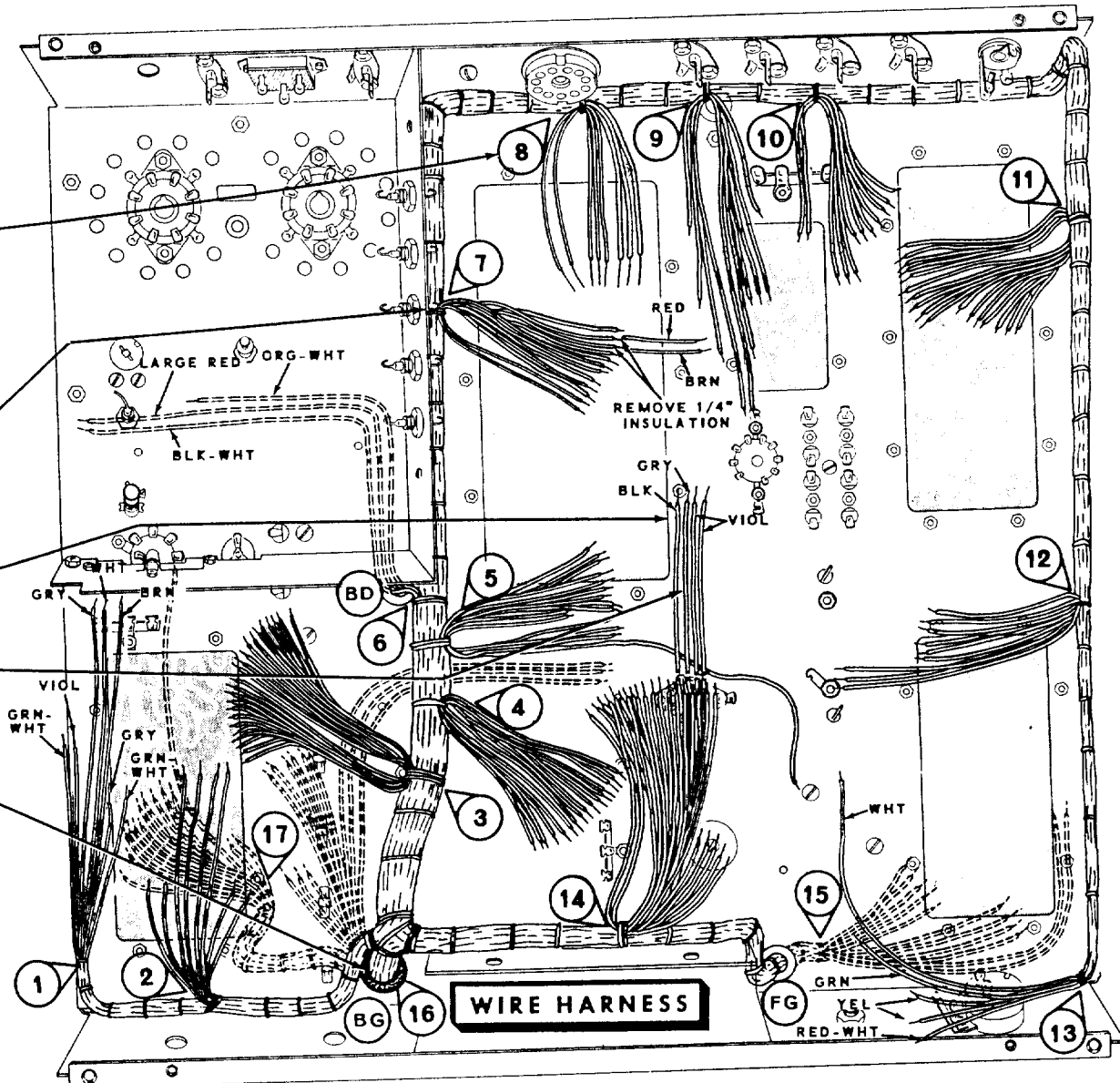

NOTE: Some wires of the wire harness may seem too long, however, it is not recommended that any wires be shortened. Also, not all wires at a BO will be connected at one time. Some will be connected in later Pictorials.

PICTORIAL 3-1

HEATHKIT®

## WIRING-SECTION A

- ( ) Prepare a choke-capacitor combination using choke #45-51 and a 22  $\mu\text{mf}$  mica capacitor.

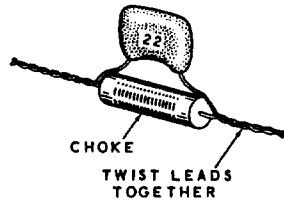

- ( ) Choke-capacitor combination from AB2 (S-2) to AC3 (NS).
- ( ) 10  $\Omega$  (brn-blk-blk) between AD1 (NS) and AD9 (NS).
- ( ) 1-1/2" bare wire from AD7 (S-1) through AD12 (S-2) to AD8 (S-1).
- ( ) 3-1/4" brn wire from AD2 (NS) to AF7 (S-1).
- ( ) 10  $\Omega$  (brn-blk-blk) between AD6 (NS) and AD11 (NS).
- ( ) 10  $\Omega$  (brn-blk-blk) between AD4 (NS) and AD10 (NS).
- ( ) 4-1/2" red wire from AD3 (NS) to AF3 (NS).
- ( ) 4" red wire from AD4 (NS) to AF4 (NS).
- ( ) One end of a 6-1/2" red wire to AU (NS). The other end will be connected later.
- ( ) 9-1/2" brn wire from AL5 (NS) to AP (NS).

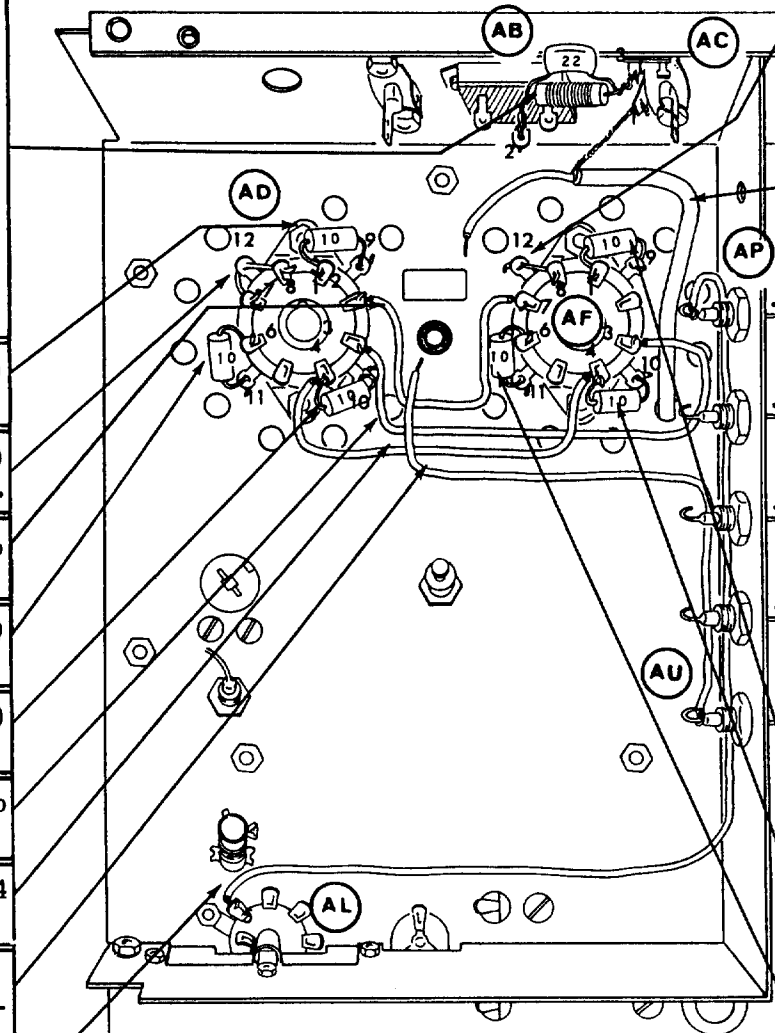

PICTORIAL 3-2

- ( ) 1" bare wire between AF8 (S-1) and AF12 (S-1).

- ( ) Prepare the ends of a 7-1/4" length of Teflon (12" length supplied) coaxial cable as shown. Discard the remaining piece.



TAKING CARE NOT TO CUT THE OUTER SHIELD OF VERY THIN WIRES, REMOVE THE OUTER INSULATION.



PUSH BACK THE SHIELD, THEN MAKE AN OPENING IN THE SHIELD AND BEND OVER AS SHOWN. PICK OUT THE INNER LEAD.



HOLD THE CABLE WITH A PAIR OF PLIERS TO PREVENT PULLING THE INNER LEAD OUT OF THE CABLE, AND REMOVE THE INNER INSULATION. STRETCH OUT THE SHIELD. APPLY SMALL AMOUNTS OF SOLDER TO THE END OF THE SHIELD AND THE INNER LEAD. USE ONLY ENOUGH HEAT FOR THE SOLDER TO FLOW.



- ( ) At the end with the shorter shield, connect the shield to AC1 (NS). The inner lead of this end of the cable will be connected later. Pass the other end of the cable through the chassis hole as shown, for connection later.

- ( ) 10  $\Omega$  (brn-blk-blk) between AF1 (NS) and AF9 (NS).

- ( ) 10  $\Omega$  (brn-blk-blk) between AF4 (NS) and AF10 (NS).

- ( ) 10  $\Omega$  (brn-blk-blk) between AF 6 (NS) and AF11 (NS).

Wiring-Section A - Continued

- ( ) .001  $\mu\text{f}$  disc between AD1 (S-2) and AD9 (NS).
- ( ) .001  $\mu\text{f}$  disc between AD2 (S-2) and AD9 (S-3).
- ( ) .001  $\mu\text{f}$  disc between AD3 (S-2) and AD10 (NS).
- ( ) .001  $\mu\text{f}$  disc between AD4 (S-3) and AD10 (S-3).
- ( ) .001  $\mu\text{f}$  disc between AD6 (S-2) and AD11 (S-2).
- ( ) Choke #45-19 from AD5 (S-1) to AH (NS).
- ( ) Choke #45-19 from AF5 (S-1) to AH (NS).
- ( ) 50  $\mu\text{f}$  mica, with 1" of sleeving on each lead, from AH (NS) to AK2 (NS).
- ( ) Lead of AJ to AK1 (NS).
- ( ) One lead of a 1  $\mu\text{f}$  phenolic (brn-blk-wht) through AL7 (S-2) to AK2 (NS). The other lead to AM1 (S-1).
- ( ) .001  $\mu\text{f}$  disc between AL5 (S-2) and AL10 (NS). AL10 is the center post.
- ( ) .001  $\mu\text{f}$  disc between AL8 (NS) and AL10 (NS).

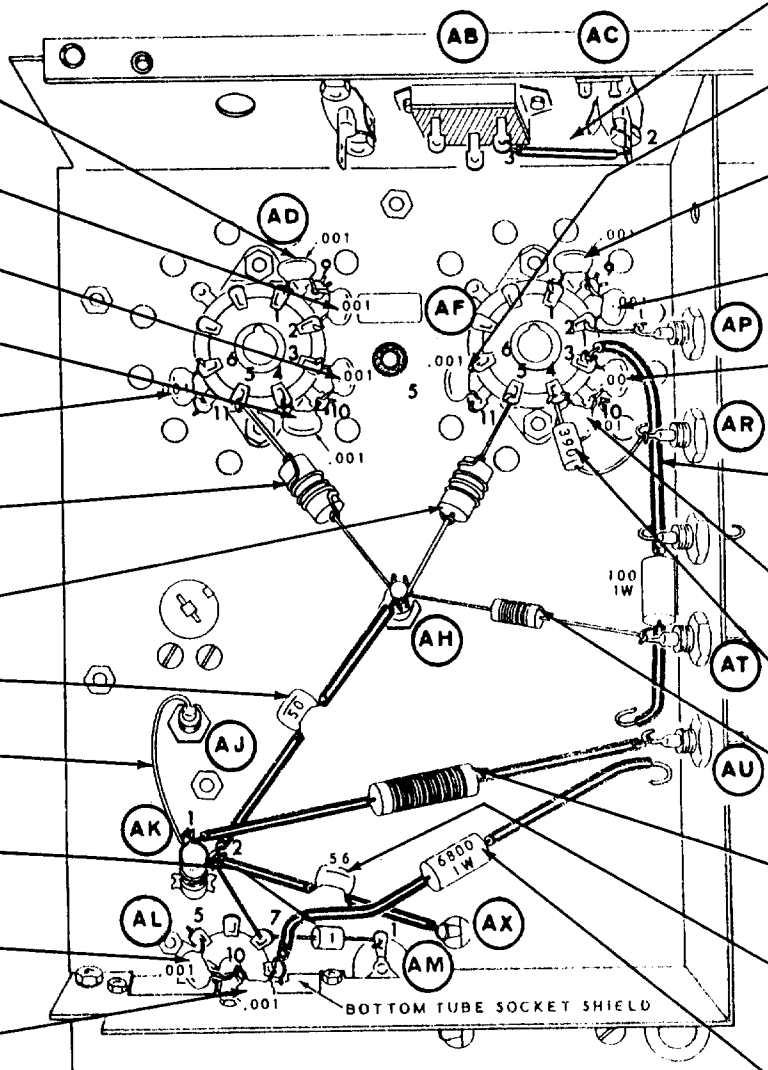

PICTORIAL 3-3

- ( ) 1-1/4" bare wire, with 5/8" of sleeving. from AB3 (S-1) to AC2 (S-1).
- ( ) .001  $\mu\text{f}$  disc between AF6 (S-2) and AF11 (S-2).
- ( ) .001  $\mu\text{f}$  disc between AF1 (S-2) and AF9 (NS).
- ( ) One lead of a .001  $\mu\text{f}$  disc through AF2 (S-2) to AP (S-2). The other lead to AF9 (S-3).
- ( ) .001  $\mu\text{f}$  disc between AF3 (NS) and AF10 (NS).
- ( ) 100  $\Omega$  1 watt (brn-blk-brn) with 1-1/4" of sleeving on each lead. Connect either lead to AF3 (S-3). The other lead will be connected later.
- ( ) .001  $\mu\text{f}$  disc between AF4 (NS) and AF10 (S-3).
- ( ) 390  $\Omega$  (org-wht-brn) from AF4 (S-4) to AR (S-1).
- ( ) Choke #45-39 from AH (S-4) to AT (S-1).
- ( ) Choke #45-36 (red dot) with 1" of sleeving on each lead, from AK1 (S-2) to AU (NS).
- ( ) 56  $\mu\text{f}$  mica, with 3/4" sleeving on each lead. Connect from AK2 (S-3) to AX (S-1).
- ( ) 6800  $\Omega$  1 watt (blu-gry-red) with 1-1/8" sleeving on each lead. Connect either lead to AL8 (S-2). The other lead will be connected later.



-----

TAKING CARE NOT TO CUT THE VERY THIN WIRES  
OF THE SHIELD, REMOVE THE OUTER INSULATION.

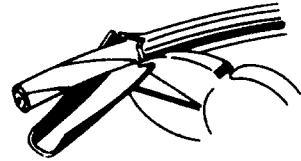

PEEL OFF THE FOIL AND STRAIGHTEN OUT THE  
THIN WIRES OF THE SHIELD.



REMOVE THE INNER INSULATION AND TWIST THE  
SMALL WIRES OF THE SHIELD. APPLY SMALL  
AMOUNTS OF SOLDER TO THE END OF THE SHIELD  
AND THE INNER LEAD.

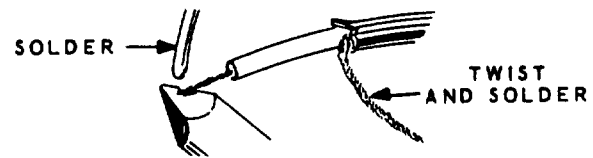

## WIRING-SECTION B

( ) 1-3/8" bare wire from AM2 (S-1) to F on the transmitter mixer circuit board (S-1).

( ) 10 KΩ (brn-blk-org) from AL2 (NS) to BA1 (NS).

NOTE: To make it easier to locate the lugs, each lug location (hole) of the rotary switches will be given a number, even though every hole does not have a lug.

Make the following connections to switch #63-384. The front wafer is the one nearest the shaft end of the switch.

( ) One end of a 4" bare wire through lug 17 of the front wafer (NS) to lug 11 of the rear wafer (NS). The other end will be connected later.

( ) 22 KΩ (red-red-org) between lugs 6 (NS) and 21 (NS) of the front wafer. Keep the body of the resistor clear of the switch.

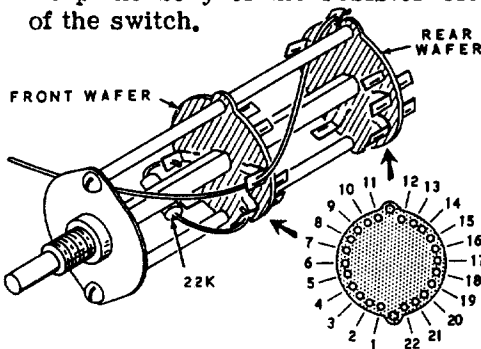

( ) Position this switch in the chassis at location BF as shown.

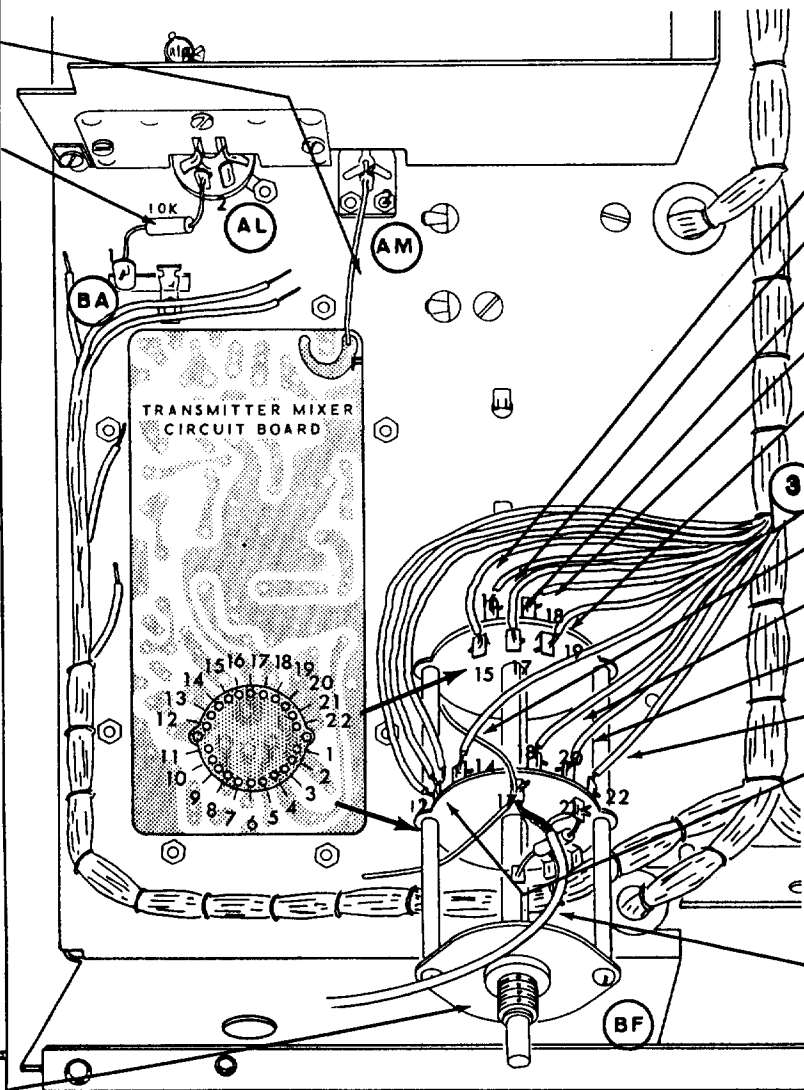

Connect the wires from BO#3 of the harness to the rear wafer of switch BF as follows. DO NOT SHORTEN ANY WIRES. Position the wires as shown in the chassis photos at the rear of the manual.

( ) Grn-gry-wht to 15 (S-1).

( ) Org to 16 (S-1).

( ) Blu to 17 (S-1).

( ) Grn to 18 (S-1).

( ) Brn to 19 (S-1).

Connect the wires from BO#3 to the front wafer of switch BF as follows:

( ) Brn-yel-wht to 14 (S-1).

( ) Blu-wht to 18 (S-1).

( ) Red to 20 (S-1).

( ) Gry-wht to 22 (S-1).

( ) Three org-wht wires to 12 (S-3).

NOTE: Cut all lengths of coaxial cable from the long (36") length of cable supplied.

( ) Prepare the ends of a 7" length of coaxial cable as follows:



( ) At the end of this cable with the shield, connect the inner lead to lug 21 (S-2) and the shield to lug 17 (S-3) of the front wafer of switch BF. The other end will be connected later.

PICTORIAL 3-4

Wiring-Section B - Continued

( ) Long gry wire from BO#1 to BA1 (NS).

Connect the wires from BO#1 to the transmitter mixer circuit board as follows:

( ) Brn to C (S-1).

( ) Wht to B (S-1).

( ) Long grn-wht to A (S-1).

( ) Viol to G (S-1).

( ) Short grn-wht to H (S-1).

( ) Short gry to J (S-1).

( ) Carefully rotate switch BF 180 degrees clockwise, looking from the front, so the wires connected to it are closest to the chassis. Install the switch at BF using a 3/8" control solder lug, a 3/8" flat control washer, and a 3/8"-32 control nut. Position the switch and solder lug as shown.

3/8" CONTROL SOLDER LUG

3/8" CONTROL FLAT WASHER

3/8"-32 CONTROL NUT

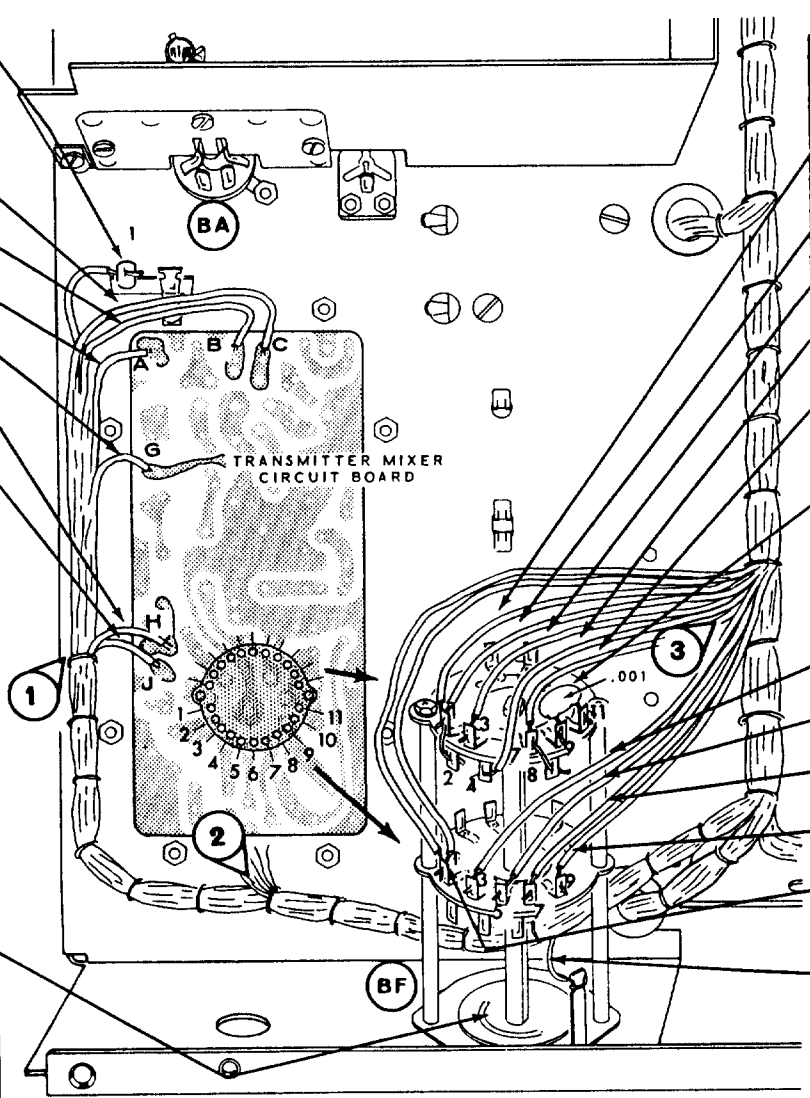

Connect the wires from BO#3 to the rear wafer of switch BF as follows:

( ) Either gry through 1 (NS) to 2 (S-1). Remove 1/2" insulation from wire end.

( ) Other gry to 1 (S-3).

( ) Yel to 3 (S-1).

( ) Grn-wht to 4 (S-1).

( ) Blk through 7 (S-2) to 8 (S-1). Remove 1/2" of insulation from wire end.

( ) .001  $\mu$ fd disc between 9 (NS) and 11 (NS).

Connect the wires from BO#3 to the front wafer of switch BF as follows:

( ) Either brn-wht to 3 (S-1).

( ) Other brn-wht to 5 (S-1).

( ) Yel-wht to 7 (S-1).

( ) Wht to 9 (S-1).

( ) Both red-wht to 1 (S-2).

( ) Bare wire from lug 17 on front wafer of switch BF to control solder lug (NS). Do not shorten this wire as it will be used as a tie point later. Position the wire near lug 6 of BF.

PICTORIAL 3-5

Wiring-Section B - Continued

( ) .001  $\mu$ f disc between AL1 (NS) and AL10 (NS). Now solder the bent lugs (3, 4, and 9), the capacitor leads, and the bottom tube socket shield to AL10 (S-6).

( ) 100  $\Omega$  (brn-blk-brn) from AL1 (S-2) to BA2 (NS).

( ) 220 K $\Omega$  (red-red-yel) from BA1 (NS) to A on the transmitter mixer circuit board (S-1).

( ) .001  $\mu$ f disc between BA1 (S-4) and BA2 (S-2).

( ) 22  $\mu$ f mica, with 1/2" of sleeving on each lead, from AL2 (S-2) to D on the transmitter mixer circuit board (S-1).

Connect the wires from BO#2 to the transmitter mixer circuit board as follows:

( ) Both red to N (S-2).

( ) Both brn to M (S-2).

( ) Wht to L (S-1).

( ) Yel-wht to K (S-1).

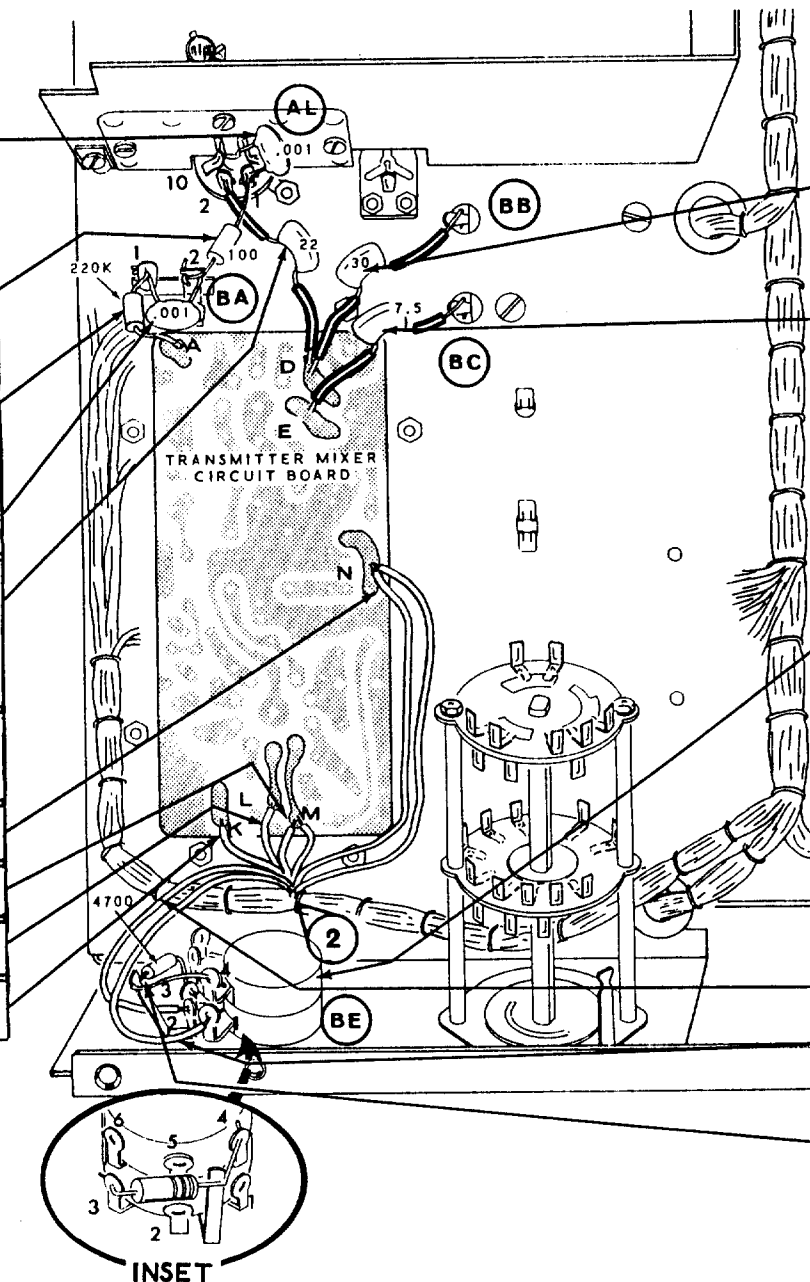

( ) 30  $\mu$ f mica, with 1/2" of sleeving on each lead, from BB (S-1) to D on the transmitter mixer circuit board (S-1).

( ) 7.5  $\mu$ f mica, with 1/2" of sleeving on each lead, from BC (S-1) to E on the transmitter mixer circuit board (S-1).

( ) 10 K $\Omega$  and 1 megohm dual control #12-48, at BE. Use a 3/8" control solder lug, a 3/8" flat washer, and a 3/8-32 control nut. Position the control and solder lug as shown.

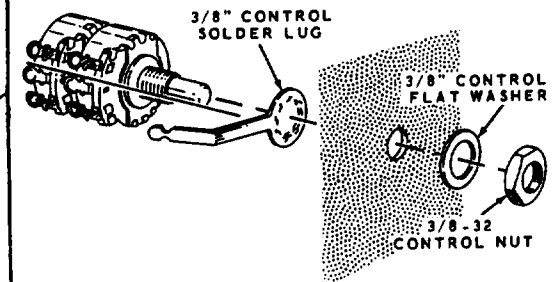

Connect the wires from BO#2 to control BE as follows:

( ) Grn-gry-wht to lug 2 (S-1).

( ) Gry to lug 1 (S-1).

( ) One lead of a 4700  $\Omega$  (yel-viol-red) around the control solder lug (NS) to BE4 (S-1). The other lead to BE3 (S-1).

PICTORIAL 3-6

# WIRING-SECTION C

- ( ) 2-1/2" bare wire from CA (S-1) to CC2 (S-1).

PUSH THE WIRE INTO THE HOLE UNTIL IT COMES OUT OF THE END OF THE PIN. APPLY SOLDER TO THE TIP OF THE HEATED PIN. SOLDER WILL FLOW UP INTO THE PIN BY CAPILLARY ACTION. CUT OFF THE EXCESS WIRE AT THE END OF THE PIN.

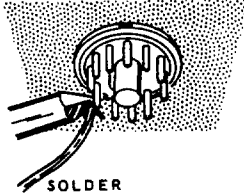

NOTE: In some of the following steps, only one lead of a capacitor will be connected. The other lead will be connected later. The lead being connected should be pushed as far as possible into the pin of plug CC.

Connect the wires from BO#8 as follows:

- ( ) Large red and one lead of a .005  $\mu$ fd 1,4 KV disc to CC4 (S-2).
- ( ) Brn and one lead of a .005  $\mu$ fd disc to CC6 (S-2).

Connect the wires from BO#7 as follows:

- ( ) Three brn to AP (S-3).
- ( ) Blk-wht to AR (S-1).
- ( ) Brn-yel-wht to AS (S-1).
- ( ) Grn-wht to AT (S-1).
- ( ) Four red to AU (S-4).

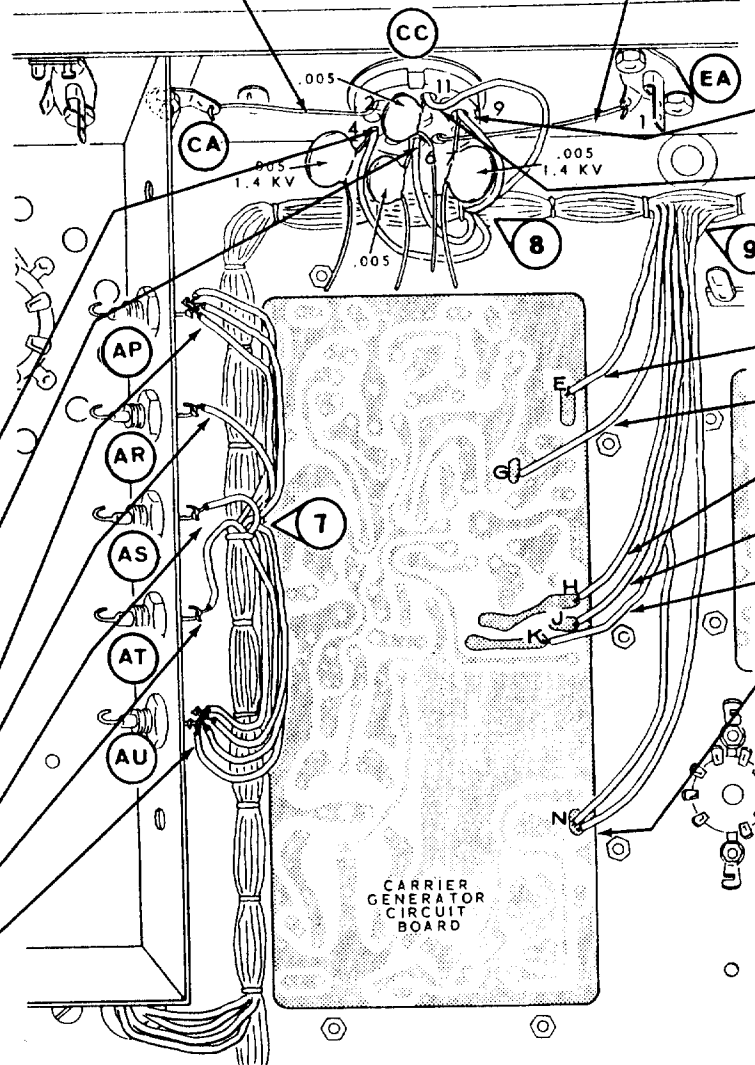

PICTORIAL 3-7

- ( ) 2-3/4" bare wire from CC7 (S-1) to EA1 (S-1). Position this wire behind the harness wires.

Connect the wires from BO#8 as follows:

- ( ) Either large blk and one lead of a .005  $\mu$ fd 1,4 KV disc to CC9 (S-2).
- ( ) Either grn-gry-wht and one lead of a .005  $\mu$ fd disc to CC11 (S-2).

Connect the wires from BO#9 to the carrier generator circuit board as follows:

- ( ) Red to E (S-1).
- ( ) Yel to G (S-1).
- ( ) Blk-wht to H (S-1).
- ( ) Org to J (S-1).
- ( ) Blu-wht to K (S-1).
- ( ) Both org-wht to N (S-2).

Wiring-Section C - Continued

- Connect the wires from BO#8 as follows:
- ( ) Other grn-gry-wht and one lead of a .005  $\mu$ fd disc to CC5 (S-2).
  - ( ) Small red and one lead of a .005  $\mu$ fd disc to CC3 (S-2).
  - ( ) Org and one lead of a .005  $\mu$ fd disc to CC1 (S-2).
  - ( ) Large blk and one lead of a .005  $\mu$ fd 1.4 KV disc to CC10 (S-2).
- Connect the wires from BO#5 to the carrier generator circuit board as follows:
- ( ) Blu to B (S-1)
  - ( ) Brn-yel-wht to A (S-1).

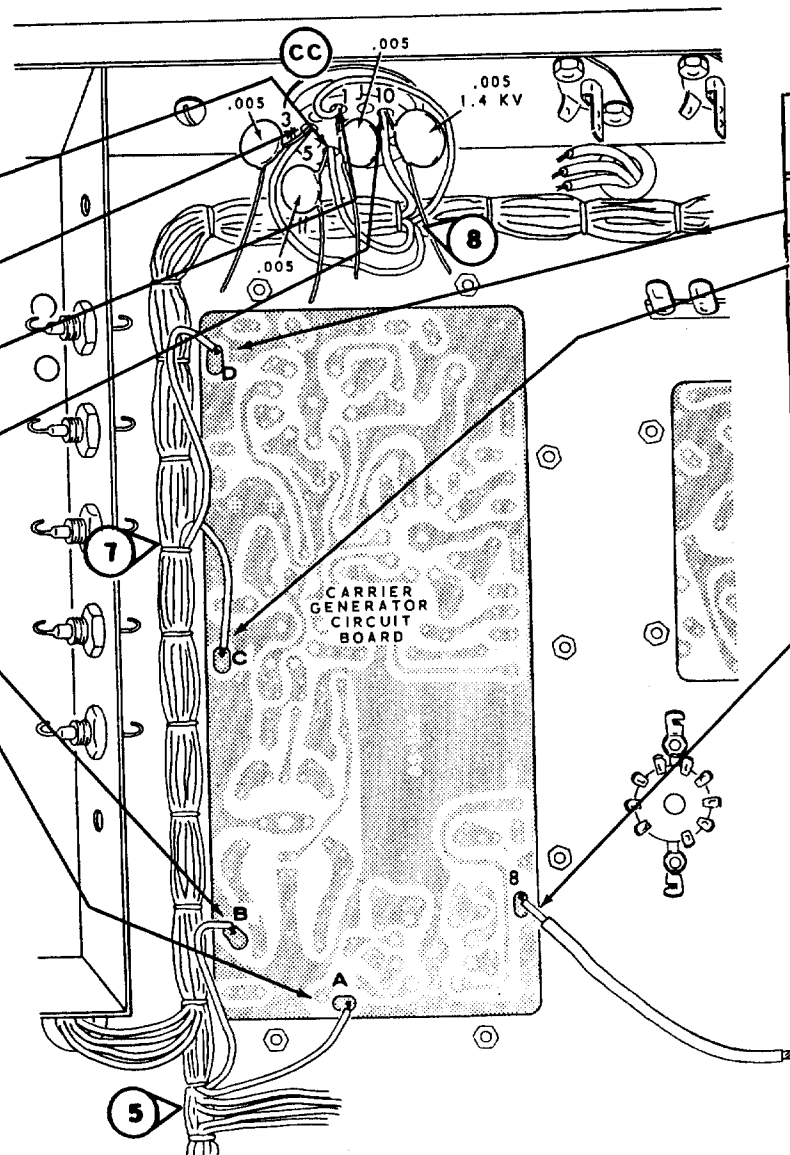

- Connect the wires from BO#7 to the carrier generator circuit board as follows:
- ( ) Yel to D (S-1).
  - ( ) Gry-wht to C (S-1).
  - ( ) Prepare the ends of a 3-3/4" coaxial cable as shown.
- 
- ( ) At the end with the shield cut off, connect the inner lead to 8 on the carrier generator circuit board (S-1). The other end will be connected later.

PICTORIAL 3-8

## WIRING-SECTION E

- ( ) 1-3/4" bare wire from EH (NS), through EL1 (S-2), to EM1 (S-1).
- ( ) 4700 Ω (yel-viol-red) from EJ2 (NS) to EH (NS).
- ( ) .001 μfd disc from EJ3 (NS) to EH (NS).
- ( ) 5 μμf disc between EJ2 (S-2) and EJ1 (NS).
- ( ) 2-1/2" bare wire from EJ10 (S-1), next to EK (NS), through EN2 (S-2), to EP2 (S-1).
- ( ) 10 KΩ (brn-blk-org) from EJ9 (NS) to EK (NS).

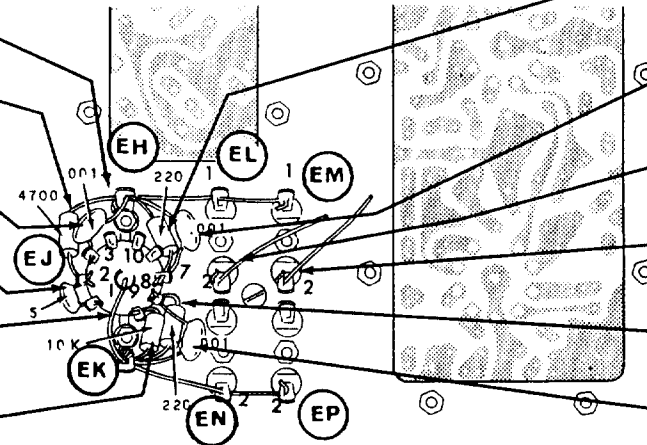

PICTORIAL 3-9

- ( ) 220 Ω (red-red-brn) from EJ7 (NS) to EH (NS).
- ( ) .001 μfd disc from EJ7 (S-2) to EH (S-5).
- ( ) One end of a 1-1/4" bare wire to EL2 (S-1). The other end will be connected later.
- ( ) One end of a 1-3/8" bare wire to EM2 (S-1). The other end will be connected later.
- ( ) 220 Ω (red-red-brn) from EJ8 (NS) to EK (NS).
- ( ) .001 μfd disc from EJ8 (S-2) to EK (NS).

- ( ) Cut one lead of choke #45-35 to 1/4". Connect this lead to EJ5 (S-1). The other end will be connected later.
- ( ) Cut one lead of another choke #45-35 to 1/4". Connect this lead to EJ4 (S-1). The other end will be connected later.
- ( ) Cut one lead of a 47 KΩ (yel-viol-org) to 1/2". Connect this lead to EJ3 (S-2). The other end will be connected later.
- ( ) Cut one lead of a 50 μμf mica to 1/2". Connect this lead to EJ9 (S-2). The other lead will be connected later.
- ( ) Cut one lead of a 560 Ω (grn-blk-brn) to 1/2". Connect this lead to EK (S-6). The other lead will be connected later.

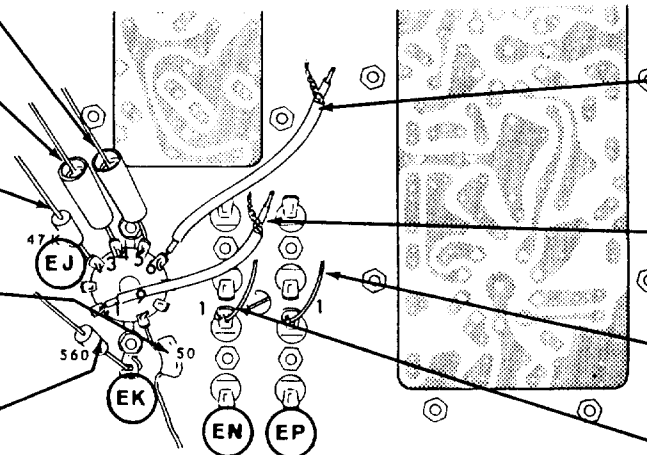

PICTORIAL 3-10

- ( ) Prepare the ends of a 4" coaxial cable as shown.
 

CUT OFF SHIELD
- ( ) At the end with the shield cut off, connect the inner lead to EJ6 (S-1). The other end will be connected later.
- ( ) Prepare the end of a 3" coaxial cable as shown above.
- ( ) At the end with the shield cut off, connect the inner lead to EJ1 (S-2). The other end will be connected later.
- ( ) One end of a 3/4" bare wire to EP1 (S-1). The other end will be connected later.
- ( ) One end of a 3/4" bare wire to EN1 (S-1). The other end will be connected later.



Parts Mounting-Section F-Continued

- ( ) Two 6-32 spade bolts on the switch bracket. Use 6-32 x 1/4" hardware. Position the offset as shown.



- ( ) 2-lug terminal strips at FA and FC on the switch bracket. Use 6-32 x 1/4" hardware as shown.

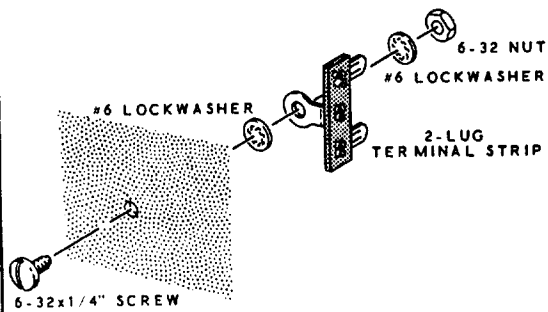

- ( ) 5/16" rubber grommets at FB and DE on the switch bracket.

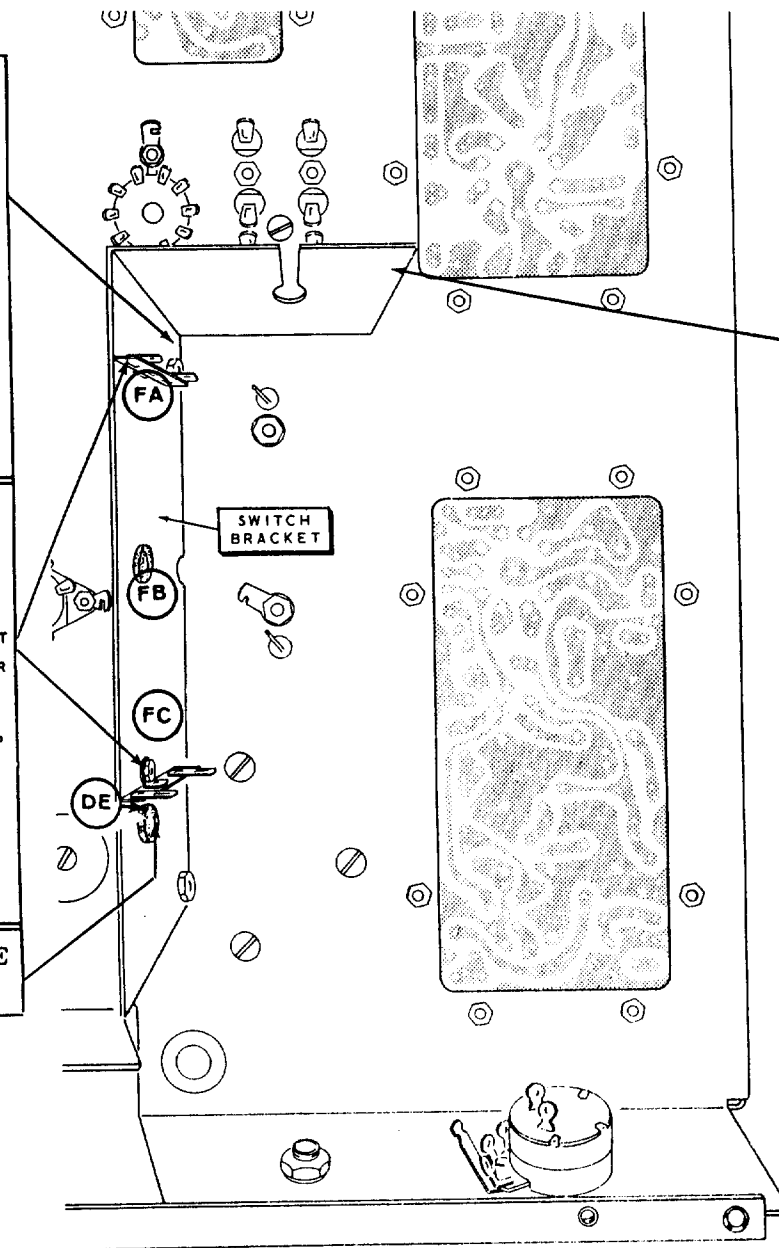

- ( ) Switch bracket to the chassis. Use #6 lockwashers and 6-32 nuts.

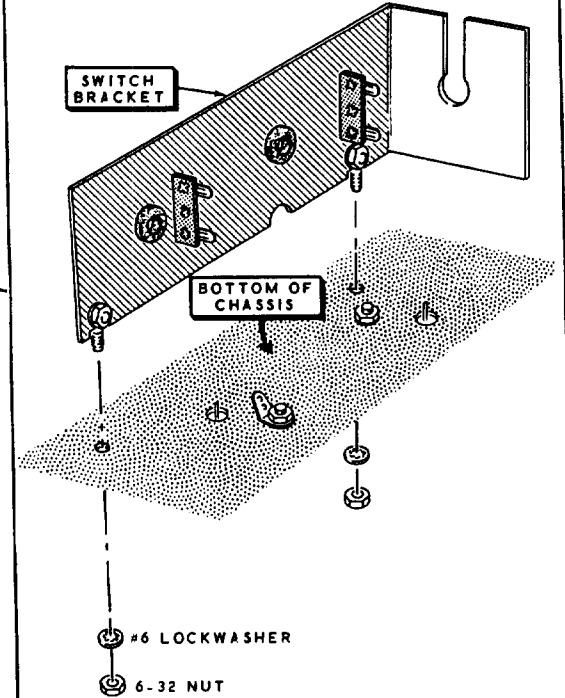

PICTORIAL 3-11

# WIRING-SECTION D

( ) Cut the connecting segments from between the specified lugs of the 30-lug terminal strip, as indicated by the arrows.

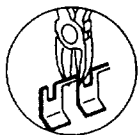

6-32 NUT  
#6 LOCKWASHER

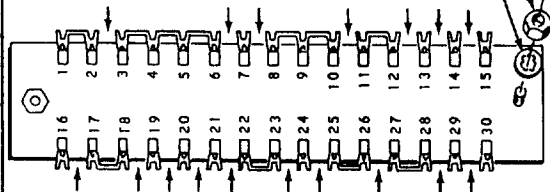

( ) 30-lug terminal strip at DA. Use #6 lockwashers and 6-32 nut. Position lug 1 as shown.

NOTE: All wires connected to the 30-lug terminal strip are connected to the (lower) hole in each lug. All components are connected to the slot of each lug, unless the step directs otherwise. After all the wires have been connected to a particular lug, it will be soldered. Be careful not to solder the upper slot, as the components will be installed there later. It is not necessary to bend the wire around the lugs.

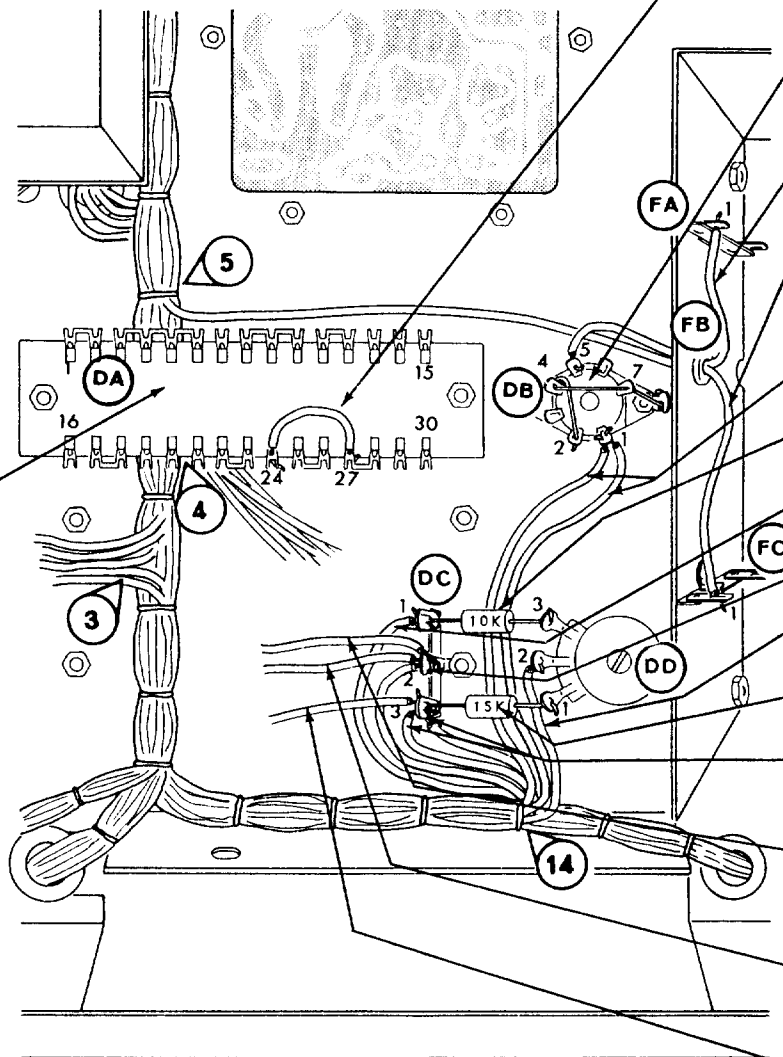

( ) 1-1/2" bare wire with 1" of sleeving between DA24 (NS) and DA27 (S-1).

( ) 1-3/4" bare wire from DB2 (S-1) through DB4 (S-2), through DB7 (S-2), to the solder lug mounted at DB (S-1).

( ) 3-1/2" viol wire from DB5 (S-1) through grommet FB to FA1 (NS).

( ) Red wire from BO#5 through grommet FB to FC1 (NS).

Connect the wires from BO#14 as follows:

( ) Both viol to DB1 (NS).

( ) 10 KΩ (brn-blk-org) from DC1 (NS) to DD3 (S-1).

( ) Org to DC1 (S-2).

( ) Blk to DC2 (NS).

( ) Grn-wht to DD2 (S-1).

( ) 15 KΩ (brn-grn-org) from DC3 (NS) to DD1 (S-1).

( ) Both gry to DC3 (NS).

( ) One end of a 3-1/2" blk wire to DC2 (NS). The other end will be connected later.

( ) One end of a 3-1/2" blk wire to DC2 (S-3). The other end will be connected later.

( ) One end of a 3-1/2" gry wire to DC3 (S-4). The other end will be connected later.

PICTORIAL 3-12

Wiring-Section D - Continued

Connect the wires from BO#5 to terminal strip DA as follows. Be sure not to connect any wires from BO#4 located under the terminal strip.

- ( ) Grn to lug 15 (S-1).
- ( ) Yel-wht to lug 14 (S-1).
- ( ) Blk-wht to lug 13 (S-1).
- ( ) Brn to lug 11 (S-1).
- ( ) Gry-wht to lug 10 (S-1).
- ( ) Brn-wht to lug 1 (S-1).
- ( ) Any org to lug 3 (S-1).
- ( ) Any org to lug 4 (S-1).
- ( ) Any org to lug 5 (S-1).
- ( ) Remaining org to lug 6 (S-1).
- ( ) Both grn-wht to lug 7 (S-2).
- ( ) .01  $\mu$ fd disc between DA24 (S-2) and DA26 (S-1). Place the leads in the lower holes.
- ( ) Relay #69-21 at DE. Use a #6 lock-washer, a 6-32 nut and a #6 flat washer. Position the relay as shown.

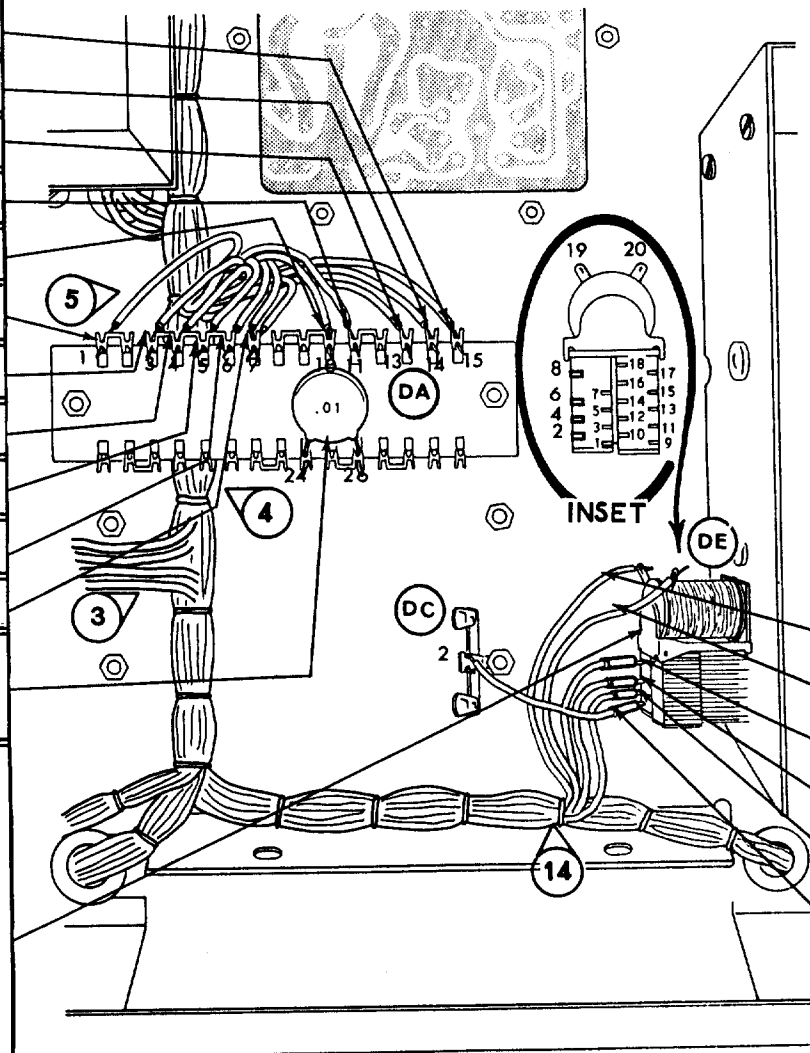
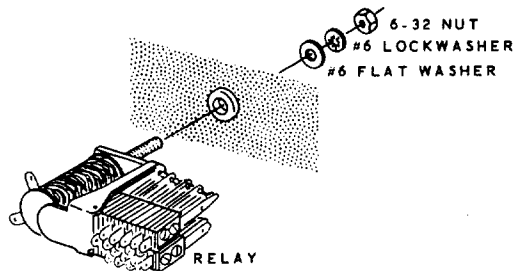

NOTE: Place a 1/2" length of sleeving over each wire that connects to lugs 1 through 18 of relay DE; do this before the wire is connected. After the connection is soldered, push the sleeving over the connection and relay lug.

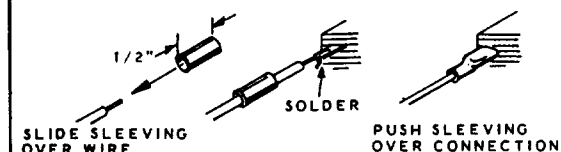

Connect the wires from BO#14 to relay DE as follows:

- ( ) Either blu to lug 19 (S-1).
- ( ) Other blu to lug 20 (S-1).
- ( ) Either grn-gry-wht to lug 8 (S-1).
- ( ) Grn to lug 6 (S-1).
- ( ) Gry-wht to lug 4 (S-1).
- ( ) Either blk wire from DC2 to lug 2 (S-1).

PICTORIAL 3-13

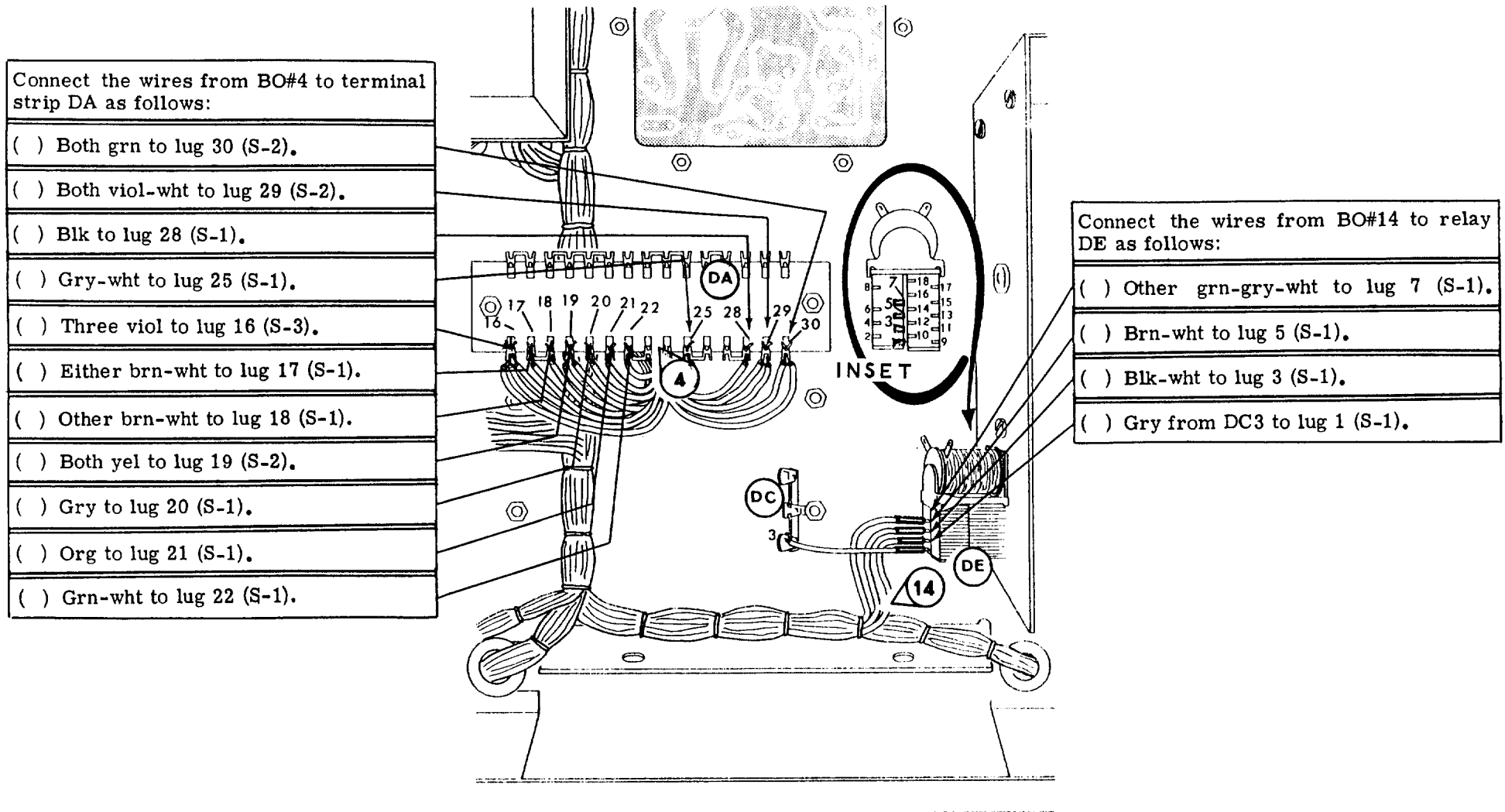

PICTORIAL 3-14

PICTORIAL 3-15

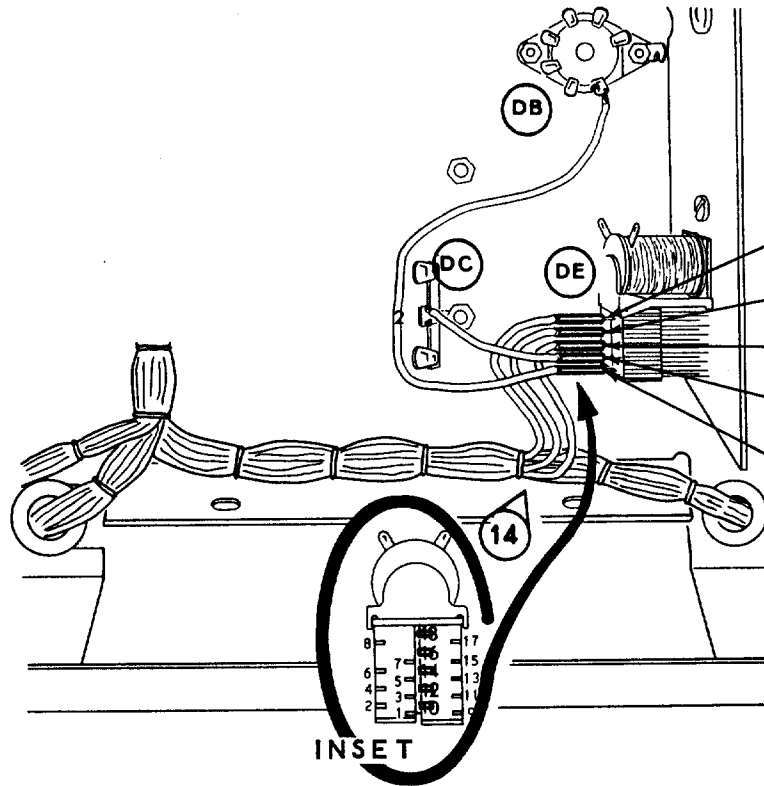

Wiring-Section D - Continued

- |  |
|--|
| Connect the wires from BO#14 to relay DE as follows: |
| ( ) Red-wht to lug 18 (S-1).                         |
| ( ) Org-wht to lug 16 (S-1).                         |
| ( ) Yel to lug 14 (S-1).                             |
| ( ) Other blk from DC2 to lug 12 (S-1).              |
| ( ) 5" viol wire from DB1 (S-3) to lug 10 (S-1).     |

PICTORIAL 3-16

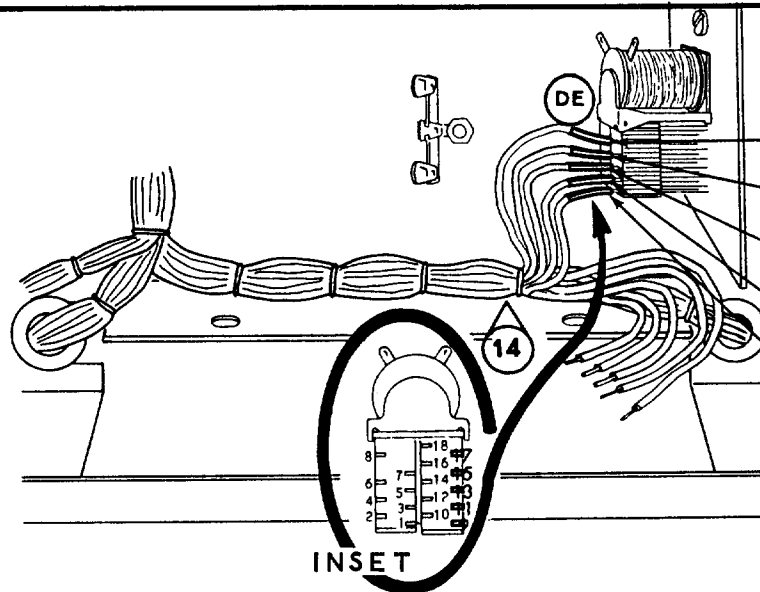

- |  |
|--|
| Connect the wires from BO#14 to relay DE as follows:       |
| ( ) Red to lug 17 (S-1).                                   |
| ( ) Viol-wht to lug 15 (S-1).                              |
| ( ) Wht to lug 13 (S-1).                                   |
| ( ) Brn-yel-wht to lug 11 (S-1).                           |
| ( ) Org-yel-wht to lug 9 (S-1).                            |
| The five remaining wires at BO#14 will be connected later. |

Wiring-Section D - Continued

Connect the following components on terminal strip DA.

- ( ) Diode #57-29. Cathode to lug 24 (S-1) and other lead to lug 9 (S-1).
- ( ) 47 K $\Omega$  (yel-viol-org) between lugs 6 (S-1) and 21 (S-1).
- ( ) 1 megohm (brn-blk-grn) between lugs 4 (NS) and 19 (NS).
- ( ) 680 K $\Omega$  (blu-gry-yel) between lugs 2 (S-1) and 17 (S-1).

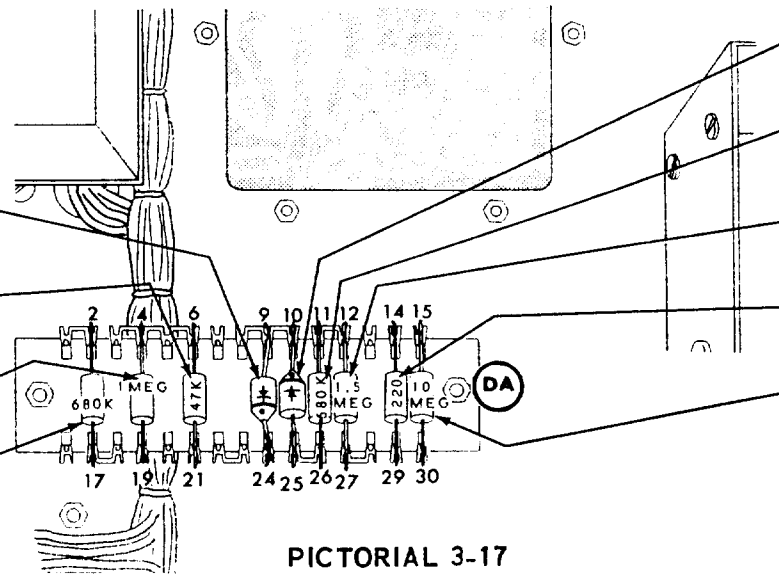

- ( ) Diode #57-29. Cathode to lug 10 (S-1) and other lead to lug 25 (S-1).
- ( ) 680 K $\Omega$  (blu-gry-yel) between lugs 11 (NS) and 26 (NS).
- ( ) 1.5 megohm (brn-grn-grn) between lugs 12 (NS) and 27 (NS).
- ( ) 220  $\Omega$  (red-red-brn) between lugs 14 (S-1) and 29 (S-1).
- ( ) 10 megohm (brn-blk-blu) between lugs 15 (NS) and 30 (NS).

PICTORIAL 3-17

Connect the following components on terminal strip DA.

- ( ) 10 K $\Omega$  (brn-blk-org) between lugs 7 (S-1) and 22 (S-1).
- ( ) 47 K $\Omega$  (yel-viol-org) between lugs 5 (S-1) and 20 (S-1).
- ( ) .2  $\mu$ fd resin between lugs 4 (S-2) and 19 (S-2). Note banded end.
- ( ) 10 K $\Omega$  1 watt (brn-blk-org) between lugs 1 (S-1) and 16 (S-1).
- ( ) 220 K $\Omega$  (red-red-yel) between lugs 3 (S-1) and 18 (S-1).

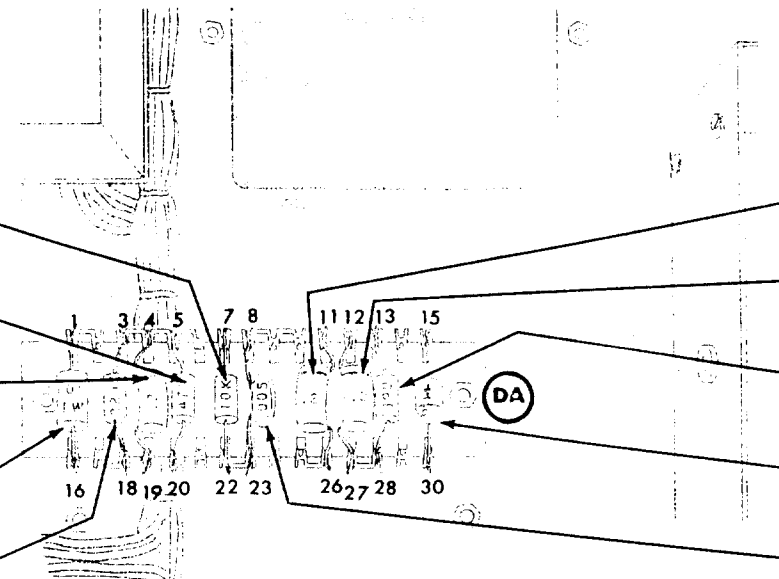

- ( ) .2  $\mu$ fd resin between lugs 11 (S-2) and 26 (S-2). Note banded end.
- ( ) .2  $\mu$ fd resin between lugs 12 (S-2) and 27 (S-2). Note banded end.
- ( ) 390  $\Omega$  (org-wht-brn) between lugs 13 (S-1) and 28 (S-1).
- ( ) Diode #57-29. Cathode to lug 30 (S-2) and other lead to lug 15 (S-2). Note banded end.
- ( ) .005  $\mu$ fd disc between lugs 8 (S-1) and 23 (S-1).

PICTORIAL 3-18

## WIRING-SECTION E

Connect the transformer wires extending from grommet EB to terminal strip EG as follows:

( ) Wht to lug 1 (NS).

( ) Grn to lug 2 (NS).

( ) Blk to lug 3 (S-1).

Connect the wires from BO#10 as follows:

( ) All four red to EG4 (S-4).

( ) All four brn to EG5 (S-4).

( ) One end of a 4" brown wire to J on the oscillator circuit board (S-1). The other end will be connected later.

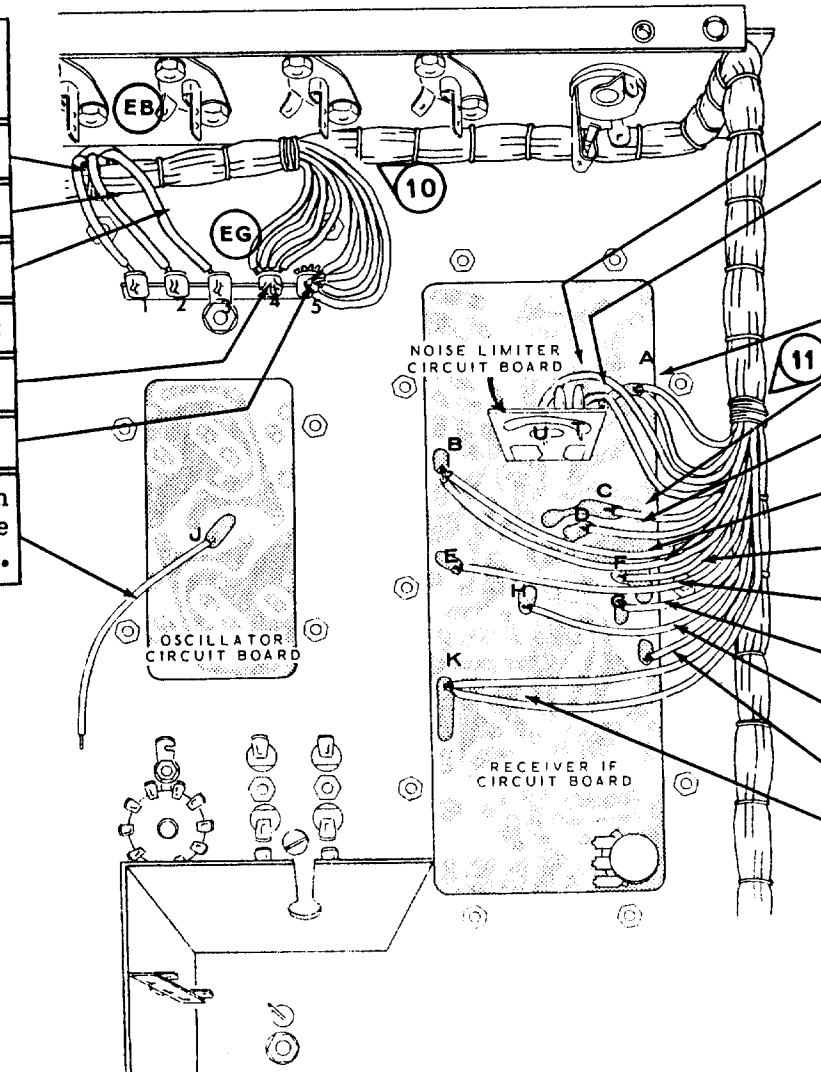

Connect the wires from BO#11 to the noise limiter circuit board as follows:

( ) Either yel to U (S-1).

( ) Other yel to T (S-1).

Connect the wires from BO#11 to the receiver IF circuit board as follows:

( ) Both red-wht to A (S-2).

( ) Blu-wht to C (S-1).

( ) Wht to D (S-1).

( ) Both viol to B (S-2).

( ) Grn to F (S-1).

( ) Blk-wht to E (S-1).

( ) Yel-wht to G (S-1).

( ) Blu to H (S-1).

( ) Org-wht to J (S-1).

( ) Both red to K (S-2).

PICTORIAL 3-19

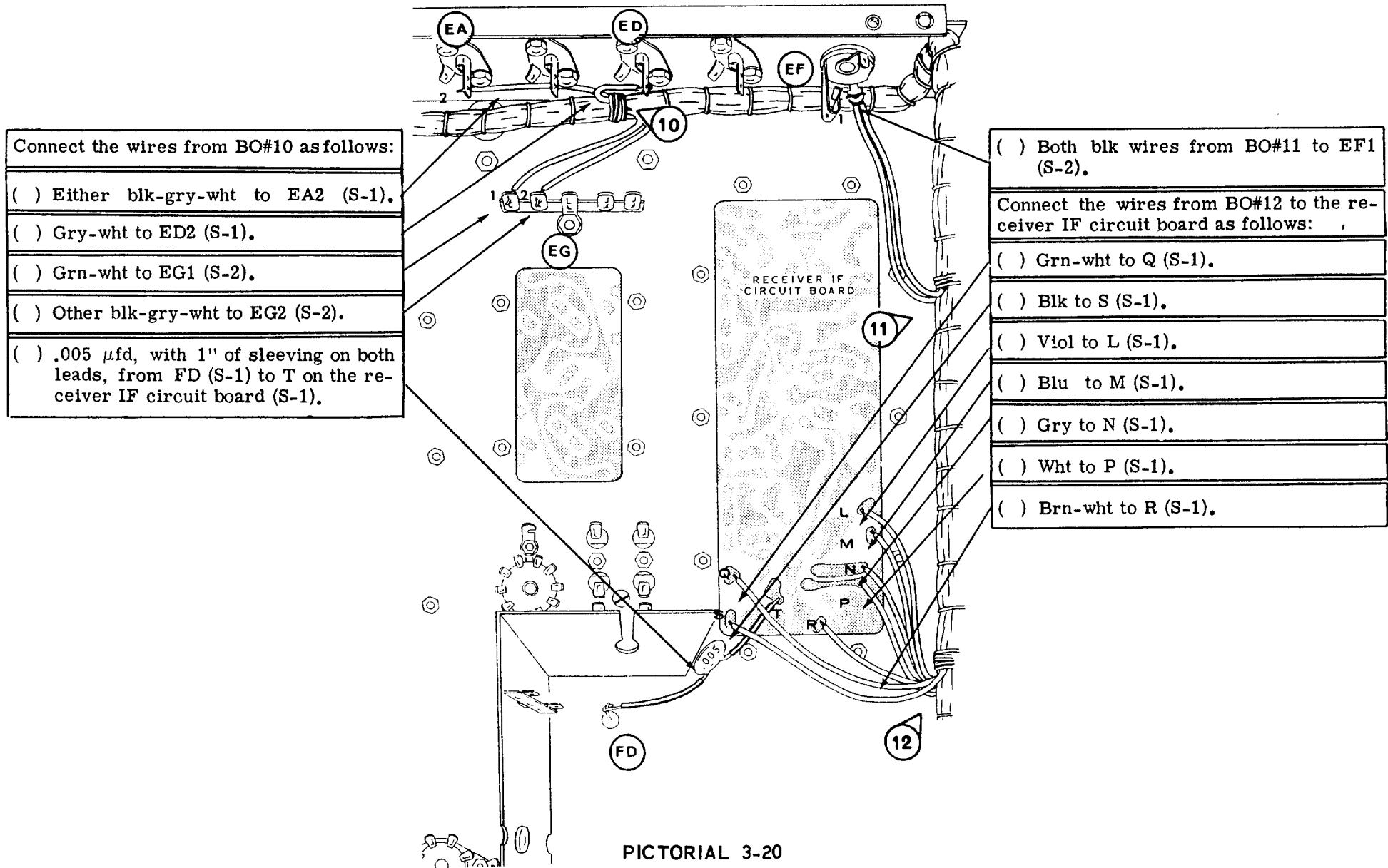



## Wiring-Section E - Continued

( ) Switch #63-420 in slot ER of the switch mounting bracket. Use a 3/8" control lockwasher, 3/8" control flat washer, and a 3/8-32 control nut. Place the end of the switch shaft through bushing FH at the front of the chassis. Do not tighten the control nut at this time.

While wiring the switch, keep the ridge of the switch bushing spaced 1/8" from the rear of the switch mounting bracket.

**CAUTION:** Be sure that EL2 and EN1 do not touch the switch spacer.

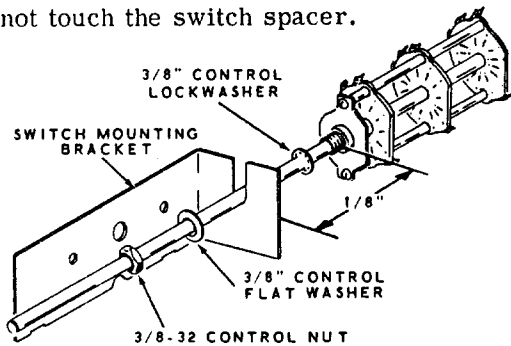

( ) 22  $\mu\text{f}$  mica between ER4 (NS) and ER5 (NS), rear wafer.

( ) 150  $\mu\text{f}$  mica between ER5 (NS) and ER6 (NS), rear wafer.

( ) Bare wire from EN1 to ER1 front wafer (S-1). Form a loop as shown.

( ) Coil #40-673 between ER4 (NS) and ER6 (NS), front wafer.

( ) 560  $\Omega$  (grn-blu-brn) from EK to ER4 front wafer (S-2).

( ) 50  $\mu\text{f}$  mica from EJ9 to ER6 front wafer (S-2). Use a 1" length of sleeving.

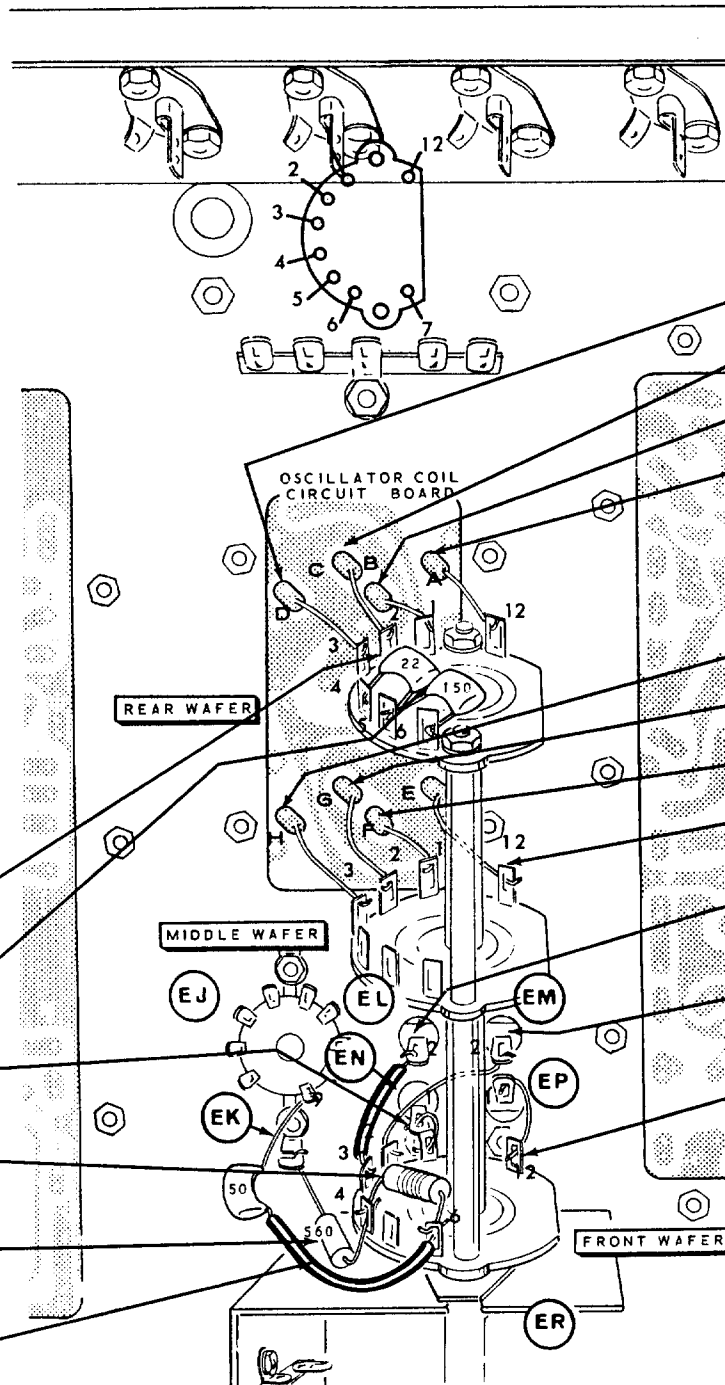

PICTORIAL 3-21

Connect the wires from the oscillator coil circuit board to the rear wafer of switch ER as follows:

( ) From D to 3 (S-1).

( ) From C to 2 (S-1).

( ) From B to 1 (S-1).

( ) From A to 12 (S-1).

Connect the wires from the oscillator coil circuit board to the middle wafer of switch ER as follows:

( ) From H to 3 (S-1).

( ) From G to 2 (S-1).

( ) From F to 1 (S-1).

( ) From E to 12 (S-1).

( ) Bare wire from EL2 to ER3 front wafer (S-1). Use a 3/4" length of sleeving.

( ) Bare wire from EM2 to ER2 front wafer (S-1). Be sure this wire does not touch the switch spacer.

( ) Bare wire from EP1 to ER12 front wafer (S-1). Form a loop as shown.

WIRING-SECTION F

- ( ) Coaxial cable from 8 on the carrier generator circuit board, Inner lead to FE (NS) and the shield to FF (S-1).
- ( ) .005  $\mu$ fd disc, with 9/16" of sleeving on each lead, from FE (S-2) to F on the receiver RF circuit board (S-1).
- ( ) 2000  $\Omega$  10 watt from FA1 (NS) to FC1 (NS).
- ( ) 22 K $\Omega$  2 watt from FA1 (S-3) to FC1 (S-3).
- Lugs 2 on FA and FC are not used.
- Connect the wires from BO#13 to control FJ as follows:
- ( ) Either yel to lug 4 (S-1).
- ( ) Other yel to lug 5 (S-1).
- ( ) .005  $\mu$ fd disc between FJ3 (NS) and the control solder lug (NS).

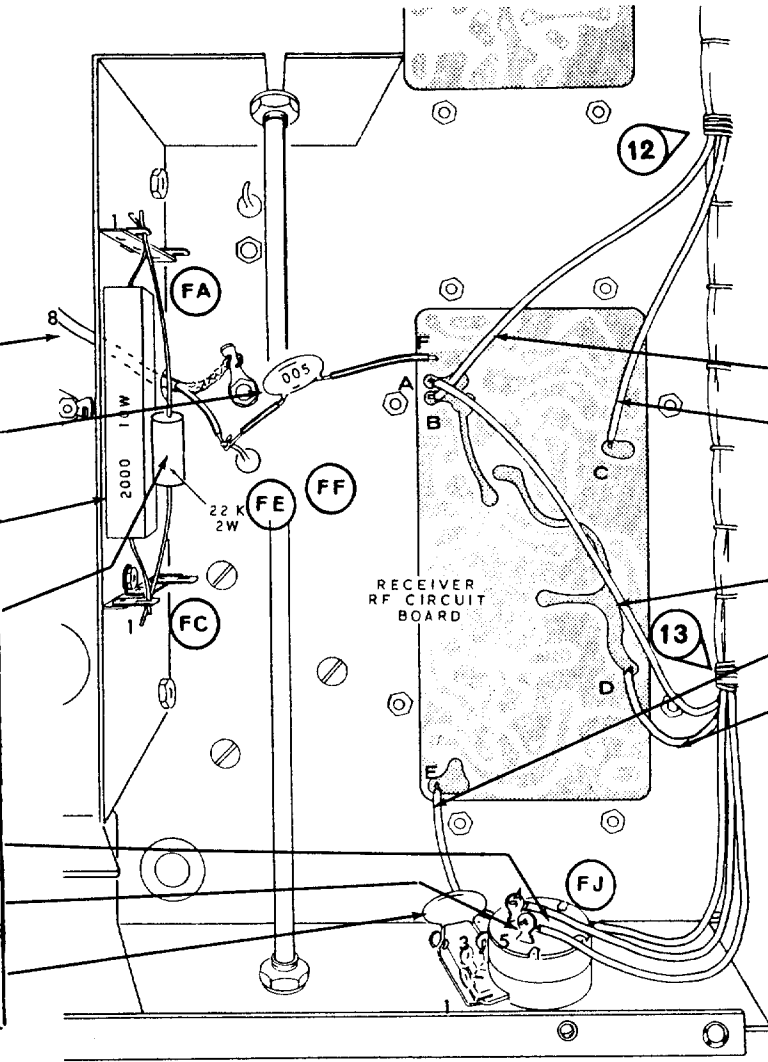

- Connect the wires from BO#12 to the receiver RF circuit board as follows:
- ( ) Brn to B (S-1).
- ( ) Gry-wht to C (S-1).
- Connect the wires from BO#13 to the receiver RF circuit board as follows:
- ( ) Wht to A (S-1).
- ( ) Grn to E (S-1).
- ( ) Red-wht to D (S-1).

PICTORIAL 3-22

## COAXIAL CABLE HARNESS PREPARATION

( ) Locate the coaxial cable harness, #134-119, and form it to the shape shown. Position the cables from each BO as shown.

The cables are color coded with color tape or paint. Those cables not marked, will be referred to as blk cables.

NOTE: Tightly twist the end of the shields of the cables. Melt a small amount of solder on the end of the shields to keep the small wire strands together. Use a pair of long-nose pliers as a heat sink when soldering the shields. Grip the shield between the connection and the cable with the pliers, thus, preventing the heat from shorting the shield to the inner lead. A rubber band around the handle of the pliers will hold them in place to free both hands for soldering.

( ) Install the harness in the bottom of the chassis as shown in Pictorial 3-23. The harness should be positioned even with the bottom edge of the chassis.

( ) At BO#3 pass all but the red cable through grommet BD. The green cable from BO#5 goes through hole AN in the driver shield.

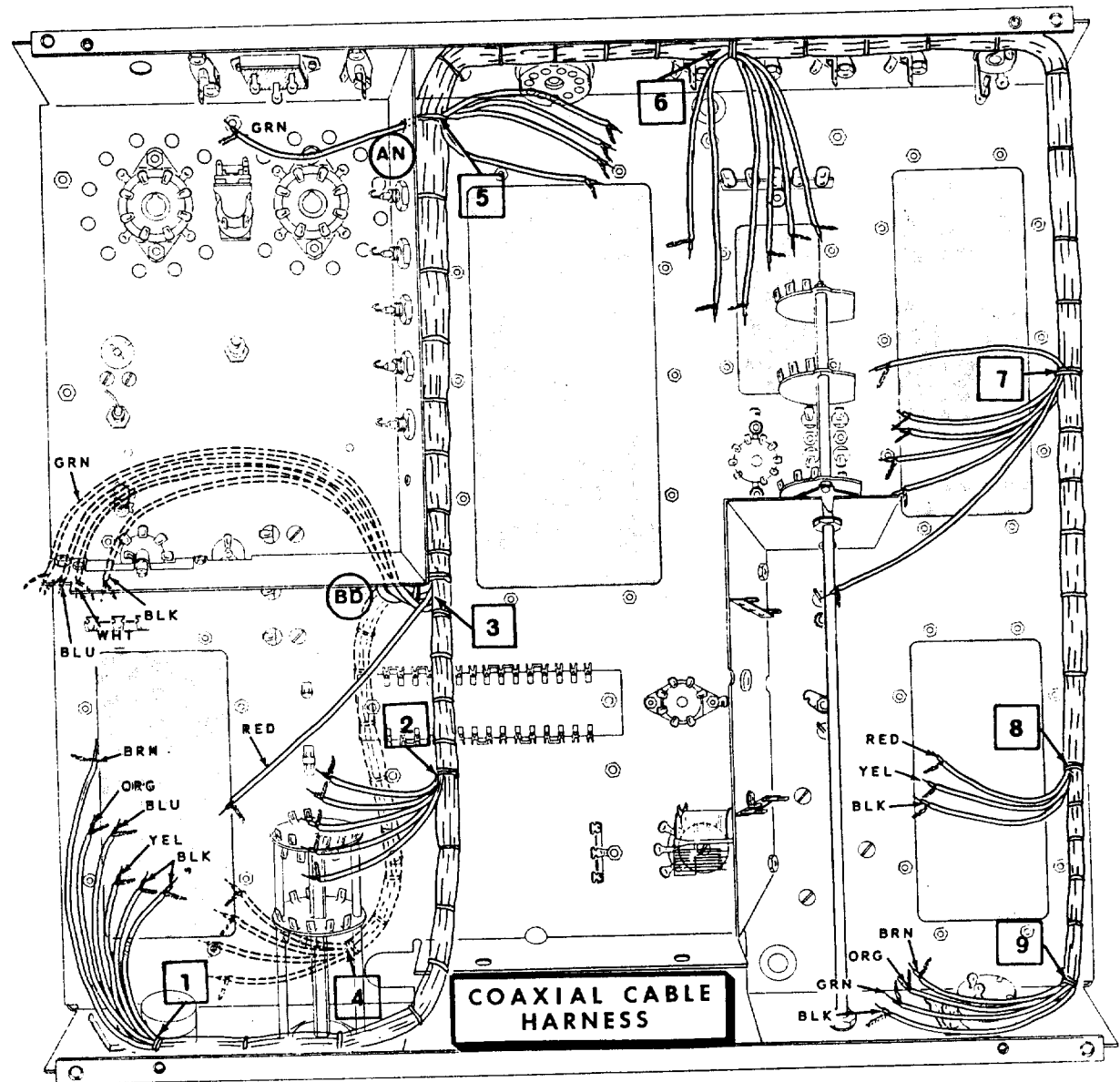

PICTORIAL 3-23

# WIRING-SECTION A

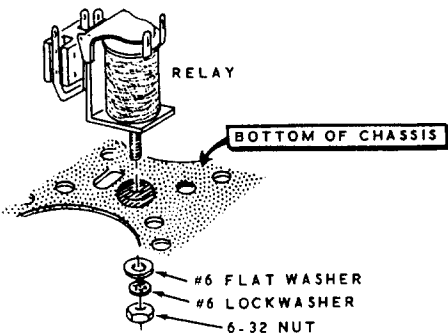
- ( ) Grn cable from BO#5. Inner lead to AC3 (S-3) and the shield to AC1 (S-2).
  - ( ) Install relay #69-17 at AE. Use a #6 flat washer, a #6 lockwasher, and a 6-32 nut. Position the relay as shown.
- 
- ( ) 1" bare wire from AA1 (S-1) to AE1 (S-1).
  - ( ) 1" bare wire from AB1 (S-1) to AE3 (S-1).

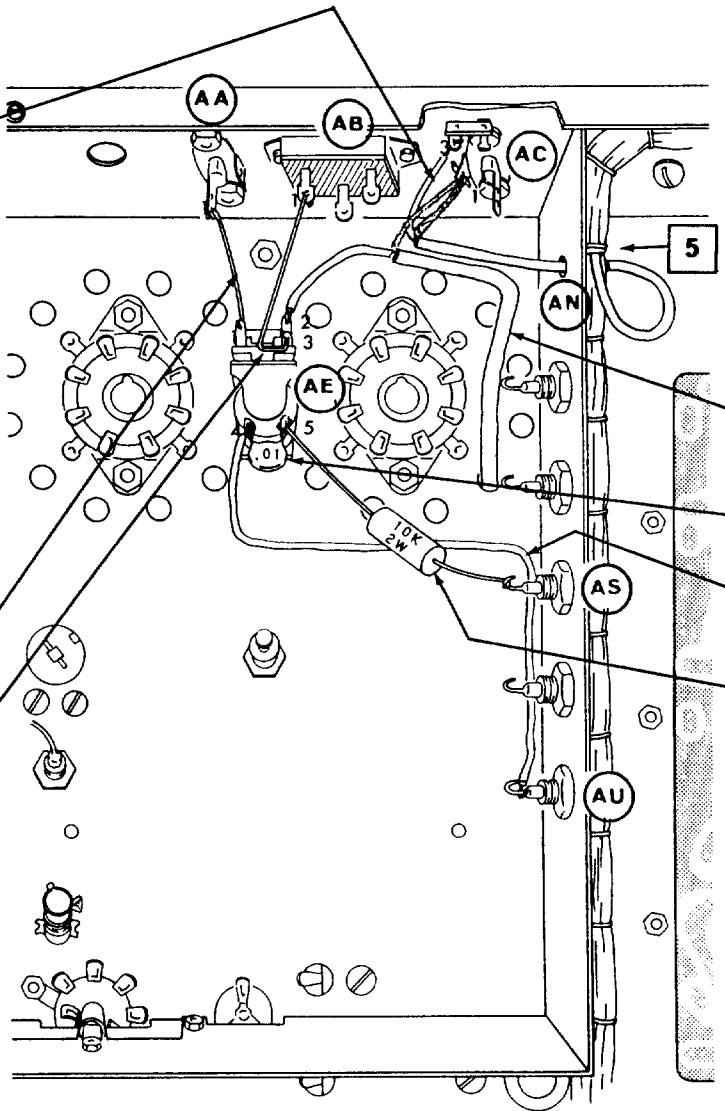

- ( ) Inner lead of coaxial cable extending from the hole in the chassis, to AE2 (S-1).
- ( ) .01  $\mu$ fd disc between AE4 (NS) and AE5 (NS).
- ( ) Free end of the red wire coming from AU to AE4 (S-2).
- ( ) 10 K $\Omega$  2 watt (brn-blk-org) from AE5 (S-2) to AS (S-1).

PICTORIAL 3-24

WIRING-SECTION B

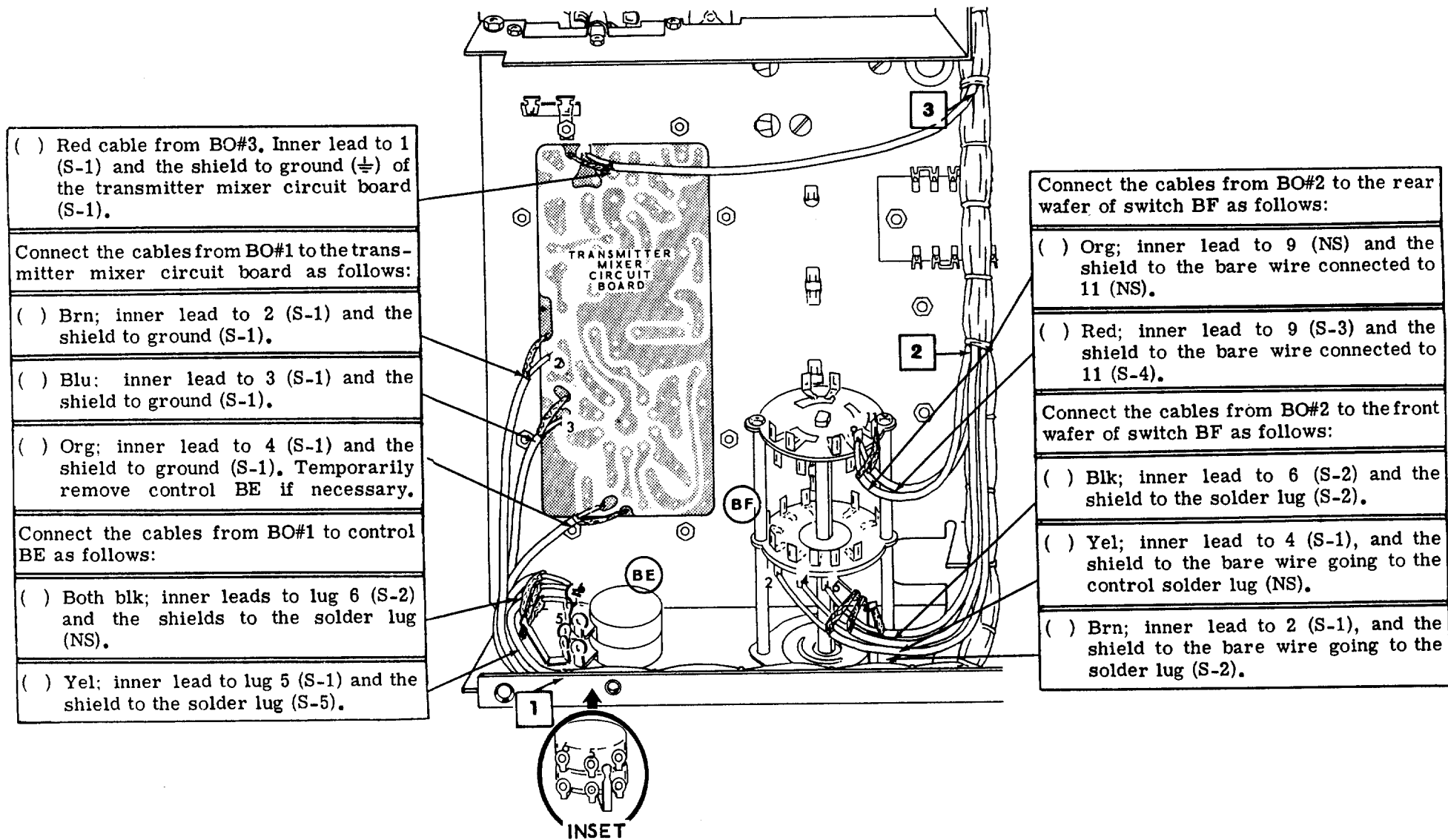

PICTORIAL 3-25

WIRING-SECTION C

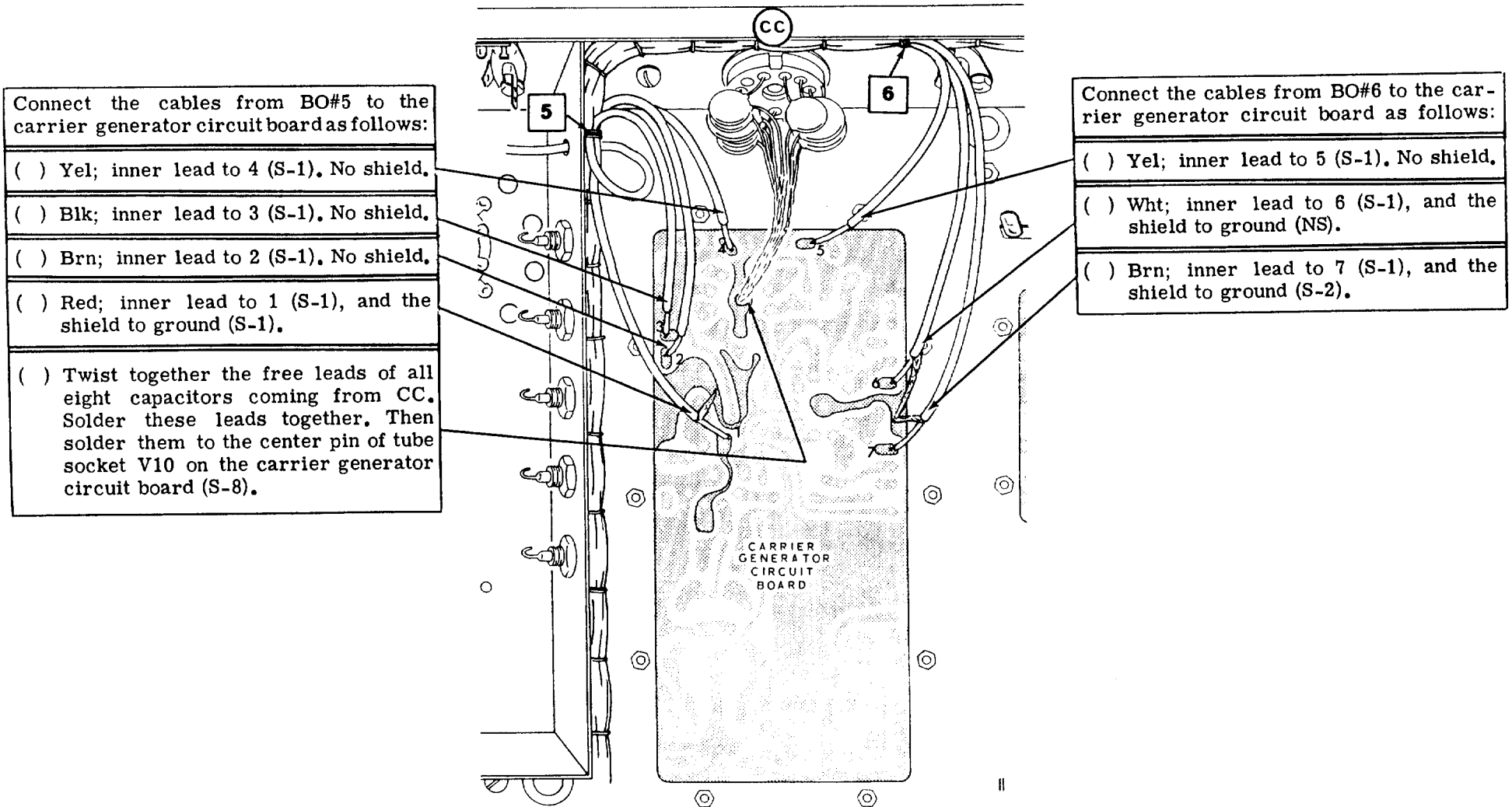

Connect the cables from BO#5 to the carrier generator circuit board as follows:

- ( ) Yel; inner lead to 4 (S-1). No shield.
- ( ) Blk; inner lead to 3 (S-1). No shield.
- ( ) Brn; inner lead to 2 (S-1). No shield.
- ( ) Red; inner lead to 1 (S-1), and the shield to ground (S-1).
- ( ) Twist together the free leads of all eight capacitors coming from CC. Solder these leads together. Then solder them to the center pin of tube socket V10 on the carrier generator circuit board (S-8).

Connect the cables from BO#6 to the carrier generator circuit board as follows:

- ( ) Yel; inner lead to 5 (S-1). No shield.
- ( ) Wht; inner lead to 6 (S-1), and the shield to ground (NS).
- ( ) Brn; inner lead to 7 (S-1), and the shield to ground (S-2).

PICTORIAL 3-26

## WIRING-SECTION E

( ) Blk cable from BO#6, Inner lead to EC2 (S-1), and the shield to ED1 (S-1).

( ) Harmonic filter #100-591 at ES on heterodyne oscillator shield. Use #3 lockwashers, a small #6 solder lug and 3-48 nuts. Position the filter and solder lug as shown.

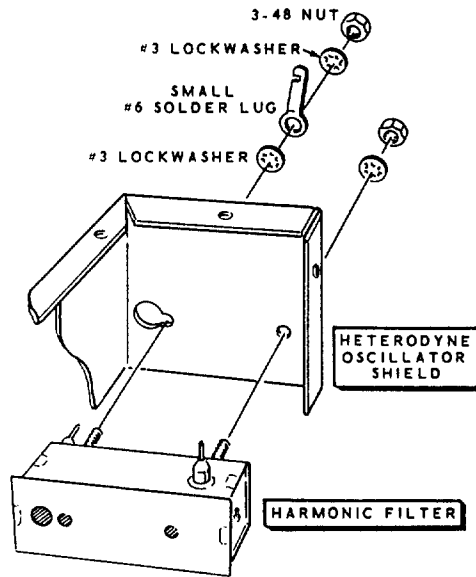

( ) Small .001  $\mu$ fd feedthrough (brn-blk-red) at ET, EU, and EW. Position as shown. Use care in mounting, as these capacitors can be broken.

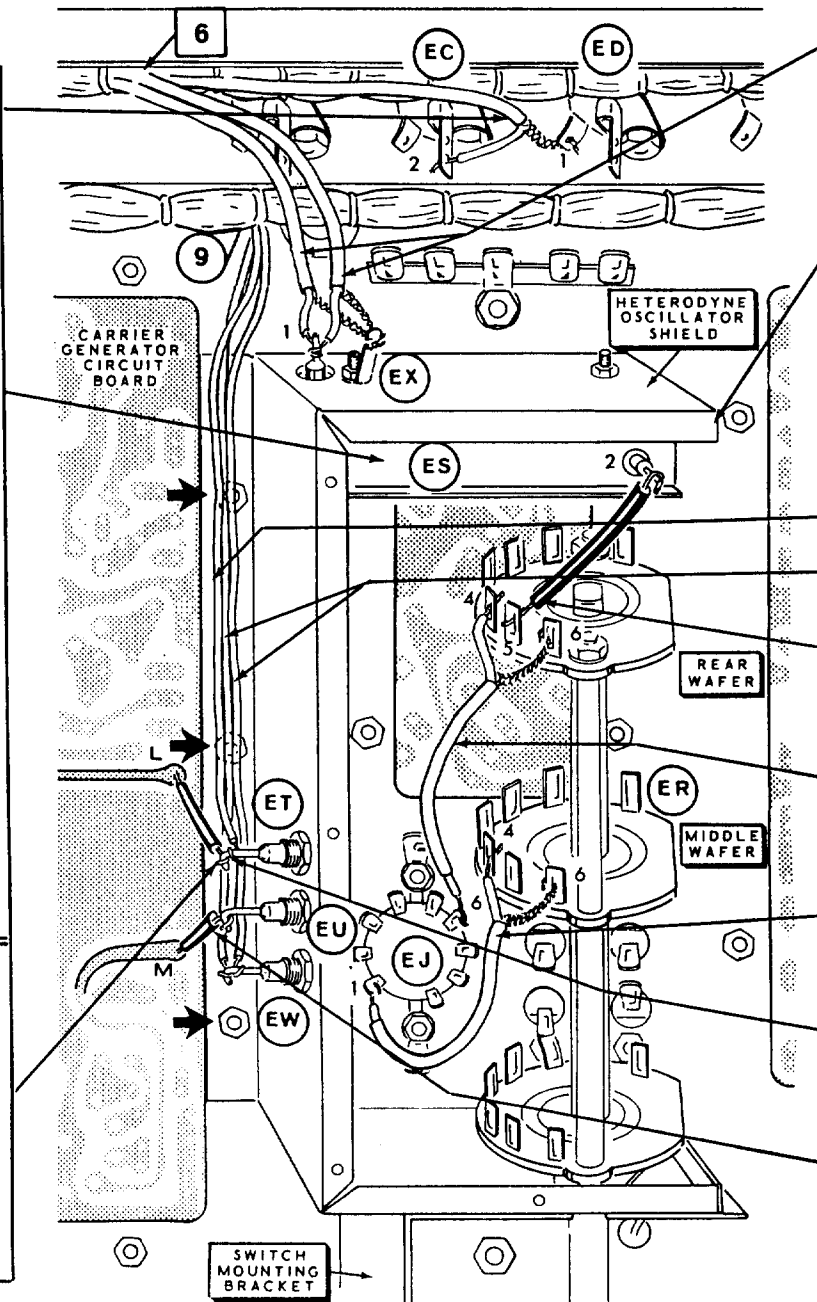
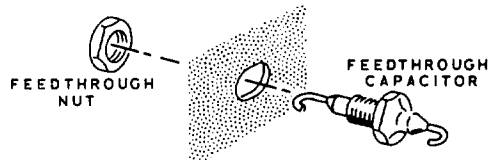

( ) Both red cables from BO#6, Inner leads to ES1 (S-2), Shields to EX (S-2).

( ) Heterodyne oscillator shield to the chassis. Use the carrier generator circuit board mounting hardware at the three locations indicated by arrows, and the control nut of switch ER. Be sure the shield fits between the switch lockwasher and the rear of the switch mounting bracket. Be sure not to pinch any wires between the shield and chassis. Do not tighten the control nut on switch ER at this time.

Connect the wires from BO#9 of the wire harness as follows:

( ) Brown to ET (NS).

( ) Both violet to EW (S-2).

( ) 1-7/8" bare wire with 1-3/8" length of sleeving from ES2 (S-1) to ER5 (S-3), rear wafer.

( ) Coaxial cable from EJ6. Inner lead to ER4 (S-2) and shield to ER6 (NS), rear wafer.

( ) Coaxial cable from EJ1. Inner lead to ER4 (S-1) and shield to ER6 (NS), middle wafer.

( ) 1-3/4" bare wire with 1-1/4" length of sleeving, from L on the carrier generator circuit board (S-1) to ET (S-2).

( ) 1-7/8" bare wire with 1-3/8" length of sleeving, from M on the carrier generator circuit board (S-1) to EU (S-1).

PICTORIAL 3-27



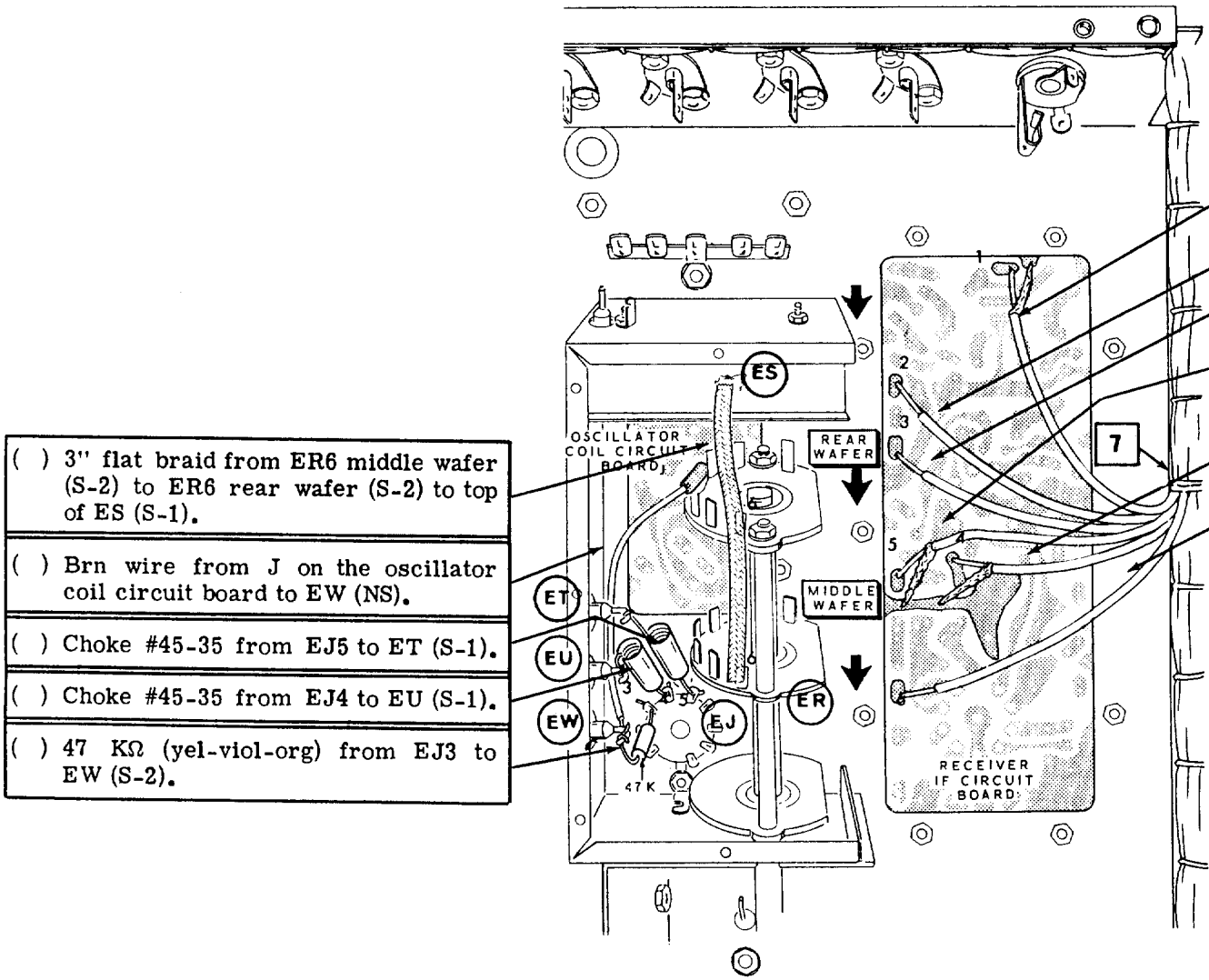

- ( ) 3" flat braid from ER6 middle wafer (S-2) to ER6 rear wafer (S-2) to top of ES (S-1).
- ( ) Brn wire from J on the oscillator coil circuit board to EW (NS).
- ( ) Choke #45-35 from EJ5 to ET (S-1).
- ( ) Choke #45-35 from EJ4 to EU (S-1).
- ( ) 47 KΩ (yel-viol-org) from EJ3 to EW (S-2).

- Connect the cables from BO#7 to the receiver IF circuit board as follows:
- ( ) Red; inner lead to 1 (S-1), and the shield to ground (S-1).
  - ( ) Blk; inner lead to 2 (S-1). No shield.
  - ( ) Grn; inner lead to 3 (S-1). No shield.
  - ( ) Org; inner lead to 5 (S-1), and the shield to ground (S-1).
  - ( ) Brn; inner lead to 4 (S-1) and the shield to ground (S-1).
  - ( ) Blu; inner lead to 6 (S-1). No shield.

( ) Heterodyne oscillator shield cover on heterodyne oscillator shield. Use the receiver IF circuit board mounting hardware at the three locations indicated by the arrows, and seven #6 x 1/4" sheet metal screws. Tighten the control nut on the switch.

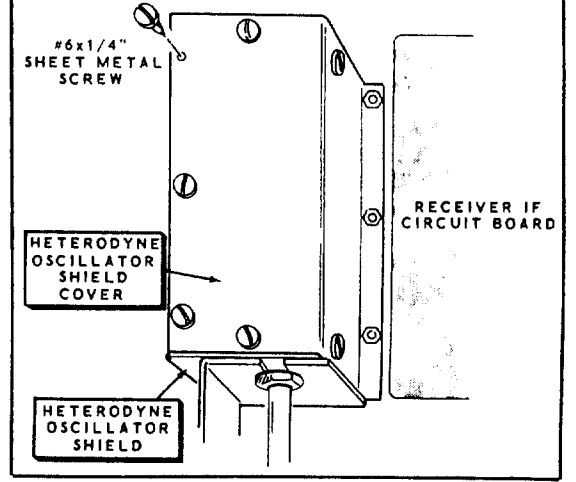

PICTORIAL 3-28



# WIRING-SECTION F

Connect the cables from BO#8 to the receiver RF circuit board as follows:

( ) Yel; inner lead to 1 (S-1) and the shield to ground on the tube socket center pin (S-1).

( ) Red; inner lead to 3 (S-1), and the shield to ground (S-1).

Connect the cables from BO#9 to control FJ as follows:

( ) Blk; inner lead to lug 3 (S-2), and the shield to the solder lug (NS).

( ) Brn; inner lead to lug 2 (S-1), and the shield to the solder lug (S-3). Be sure FJ1 is soldered to the solder lug.

( ) Blk cable from BO#8. Inner lead to 2 (S-1) and the shield to ground (S-1) of the receiver RF circuit board.

Connect the cables from BO#9 to the receiver RF circuit board as follows:

( ) Grn; inner lead to 4 (S-1), and the shield to ground (S-1).

( ) Org; inner lead to 5 (S-1), and the shield to ground (S-1).

( ) Support rails to each side of the chassis. Use 6-32 x 3/8" flat head hardware. Be sure the wires and cables are clear of the support rail mounting holes to prevent them from being damaged.

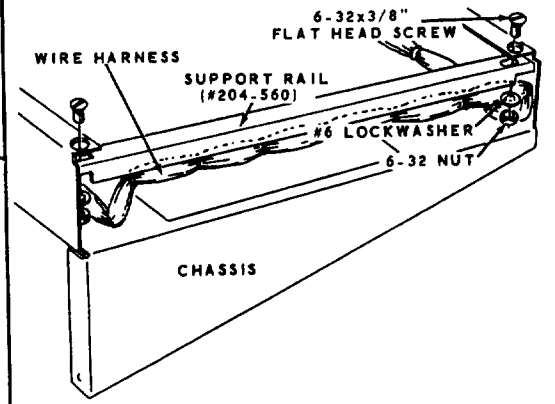
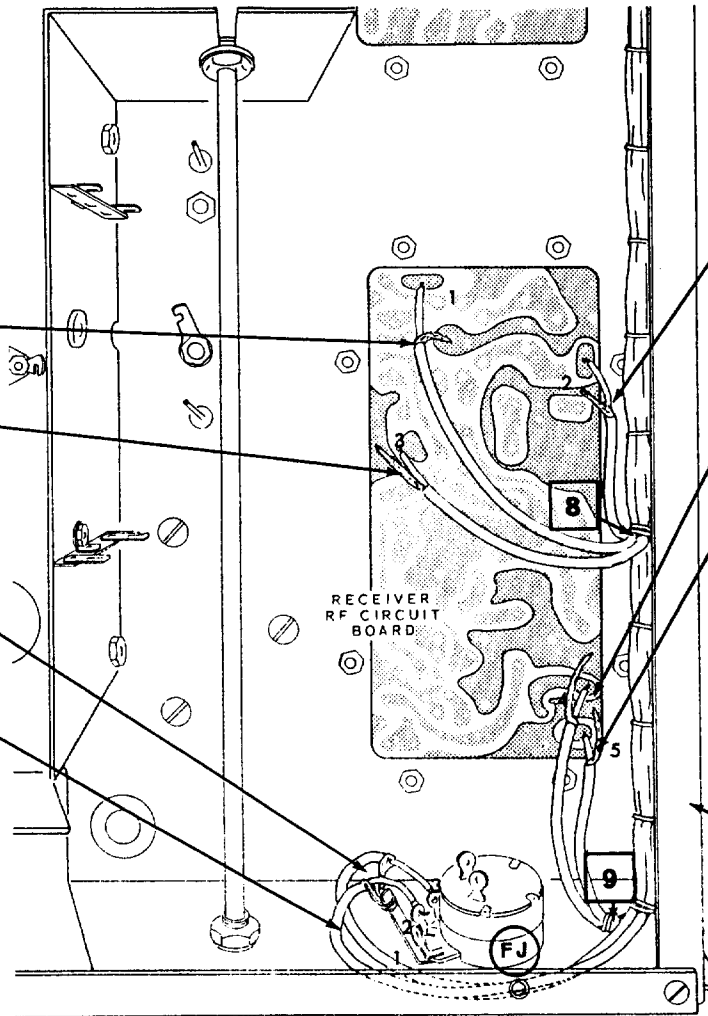

PICTORIAL 3-29

( ) Position the coaxial harness cables as shown in the photos at the rear of the manual.

# WIRING-SECTION L

NOTE: When the flat braid is connected to a solder lug, open the end of the braid and fit it over the end of the solder lug before soldering.

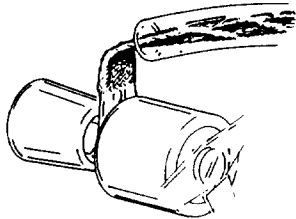

- ( ) 1-3/4" flat braid with 1-1/4" large sleeving from LA1 (S-1) to LE1 (S-1).
- ( ) 1-3/4" flat braid from LC (S-1) to LF1 (NS).
- ( ) Free lead of the germanium diode coming from LD to LJ3 (NS).
- ( ) Free lead of the 4.7  $\mu\mu\text{f}$  tubular coming from LH2 to LA3 (S-2).
- ( ) 2.2  $\mu\mu\text{f}$  phenolic (red-red-wht) from LJ3 (S-3) to LF1 (S-2).
- ( ) Free lead of choke #45-36 coming from LJ2 to LF2 (NS).
- ( ) Coaxial cable extending from the chassis. Inner lead to LF2 (S-2), and the shield to LF3 (S-1).
- ( ) Install 6146 tubes at V14 and V15.

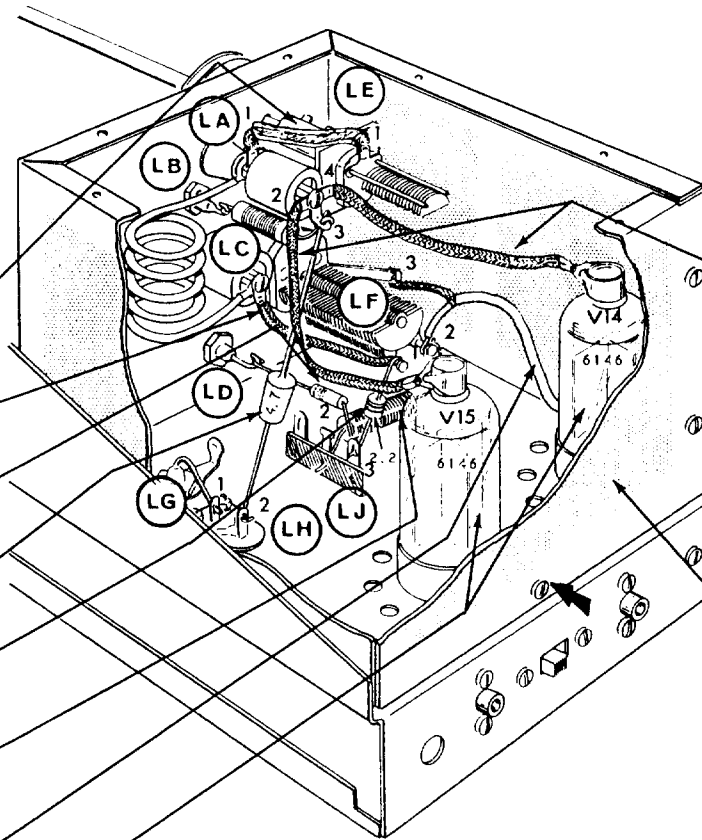

PICTORIAL 3-30

- ( ) Prepare two anode clips. Connect one end of a 2" flat braid to each clip. Place the end of the flat braid between the tabs of the anode clip. Then bend the tabs over the braid and solder the braid to the clip.

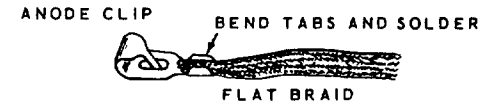

- ( ) Install one of these anode clips on the anode cap of each 6146 tube.
- ( ) Solder the end of the flat braid from V14 to LA4 (S-1). Solder the flat braid from V15 to LA2 (S-1). Be sure the braid does not touch the plates of LE.
- ( ) Be sure all connections in the final shield are soldered. Shake out any wire clippings or solder splashes.
- ( ) Final rear plate on the final shield. Use four #6 x 1/4" sheet metal screws, and a 6-32 x 1/4" screw at the location indicated by the arrow.

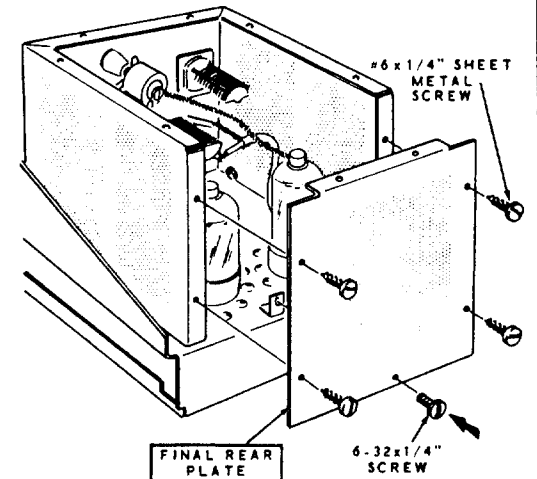

WIRING-SECTION J

- Connect the audio output transformer wires to the carrier generator circuit board as follows. Refer to Figure 3-9.
- ( ) Red to RED (S-1).
  - ( ) Blu to BLU (S-1).
- Connect the wires from BO#16 to the LMO as follows:
- ( ) Red-wht to B+ (S-1).
  - ( ) Wht to FIL (S-1).
  - ( ) Brn-wht to BIAS (S-1).

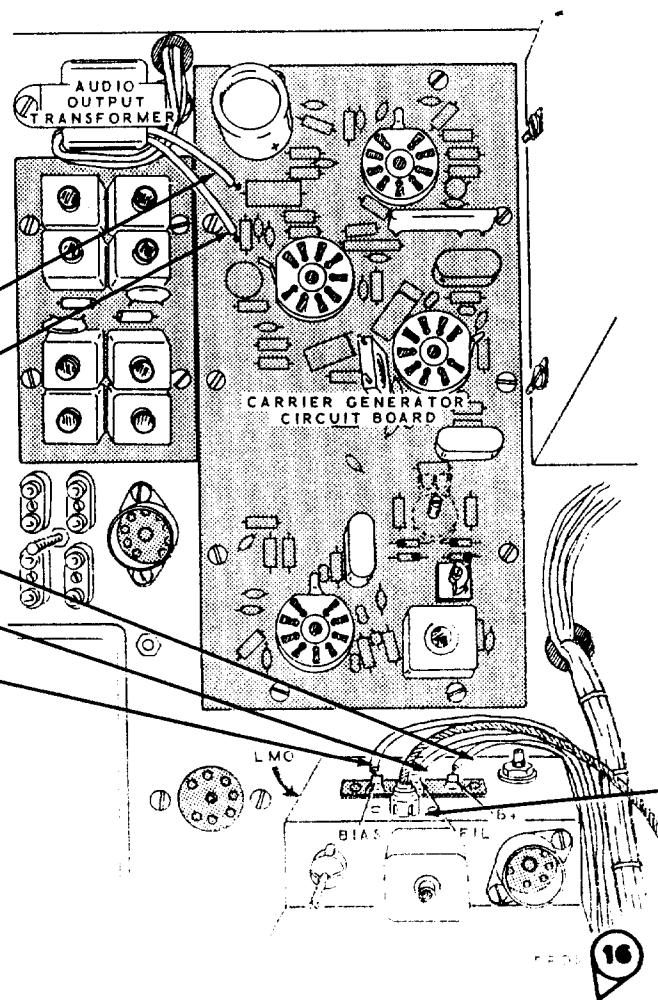

- ( ) Prepare the ends of a 12" coaxial cable as follows:

CUT THE CABLE ACCORDING TO THE DIMENSIONS BELOW. PREPARE EACH END AS SHOWN.

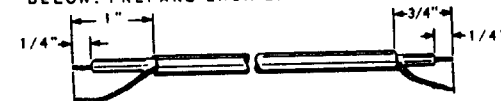

- ( ) Install a phono plug on the end of the cable, with the longest shield, as shown.

INSERT THE INNER LEAD OF THE CABLE THROUGH THE PLUG AND WRAP THE SHIELD AROUND THE PLUG.



APPLY HEAT TO THE TIP OF THE PIN ONLY LONG ENOUGH FOR THE SOLDER TO BE DRAWN UP INTO THE PIN BY CAPILLARY ACTION. CUT OFF EXCESS WIRE FROM THE TIP OF THE PIN. SOLDER THE SHIELD TO THE PLUG.

- ( ) Plug the phono plug into the socket of the LMO. Pass the other end of the cable through the cable clamp on the side of the LMO, to be connected later.

PICTORIAL 3-31

WIRING-SECTION M

- ( ) 1 megohm miniature control, #10-153, at LM. Use a 1/4" control solder lug and a 1/4-32 control nut. Bend the solder lug against lug 1 of the control as shown.

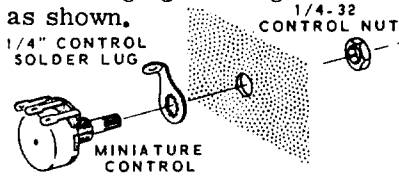

- ( ) 10 megohm miniature control, #10-154, at LL. Use a 1/4" control solder lug and a 1/4-32 control nut.

- ( ) 1 megohm miniature control, #10-153, at LK. Use a 1/4" control solder lug and a 1/4-32 control nut.

- ( ) Diode #57-29. Cathode to LK1 (NS) and the other lead to LK3 (NS). Position the diode as shown. Note banded end.

- ( ) Cut a 3-3/4" wire from the end of the blk wire at BO#16. Connect the cut off wire from MB3 (S-1) to ME3 (NS).

Connect the wires from BO#16 as follows:

- ( ) Blu-wht to MB2 (S-1).
- ( ) Grn-wht to MB1 (S-1).
- ( ) Blk-wht to MC3 (S-1).
- ( ) Yel-wht to MC2 (S-1).
- ( ) Blu to MC1 (S-1).
- ( ) Either org-yel-wht to MD2 (S-1).
- ( ) Other org-yel-wht to MD1 (S-1).
- ( ) Blk to ME3 (S-2).
- ( ) Yel to ME2 (S-1).

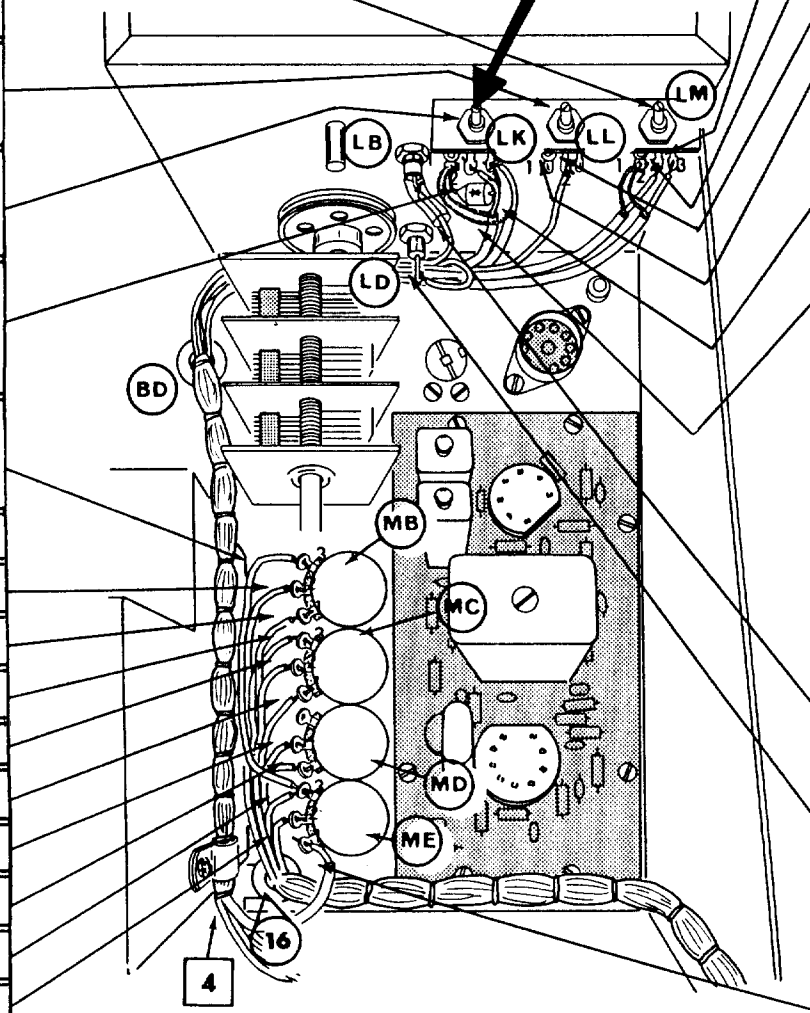
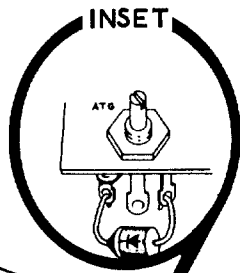

PICTORIAL 3-32

Connect the wires and cables extending from grommet BD as follows:

- ( ) Blk; inner lead to LM3 (S-1), and the shield to LM1 (NS).
- ( ) Blu; inner lead to LM2 (S-1), and the shield to LM1 (S-2). Be sure the solder lug is soldered to LM1.
- ( ) Blk-wht wire to LL2 (S-1).
- ( ) Solder the solder lug to LL1 (S-1).
- Lug LL3 is not used.
- ( ) Wht; inner lead to LK3 (S-2), and the shield to LK1 (NS).
- ( ) Grn; inner lead to LK2 (S-1), and the shield to LK1 (S-3). Be sure the solder lug is soldered to LK1.
- ( ) Now turn controls LK, LL, and LM 90 degrees counterclockwise. Position them as shown in Figure 3-9. Be sure none of the lugs short to the bracket.

Connect the wires extending from grommet BD as follows:

- ( ) Cut the lead of LB to 1/4".
- ( ) Red, with 1-1/2" large sleeving, to LB (S-1). After the connection has cooled, slide the sleeving over the connection and onto the feedthrough capacitor.
- ( ) Org-yel-wht to LD (S-1).
- ( ) Pass the cables at BO#4 through the cable clamp on the side of the LMO, to be connected later.
- ( ) Red coaxial cable from BO#4. Inner lead to ME1 (S-1). No shield.

## DIAL MOUNTING

- ( ) Nylon spiral follower on the dial pointer drive arm, #100-477. Use a 3-48 x 1/8" screw. Do not overtighten the screw.

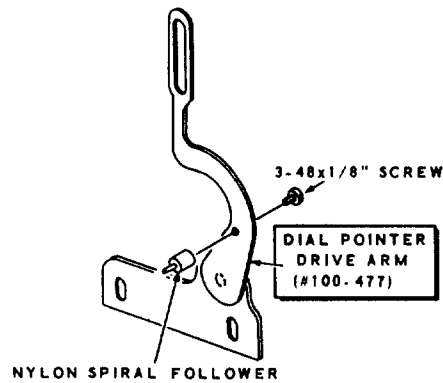

- ( ) Dial pointer drive arm on the chassis. Use 6-32 x 1/4" hardware. Position the screws in the center of the chassis and dial pointer drive arm slots. Use the open end wrench supplied.

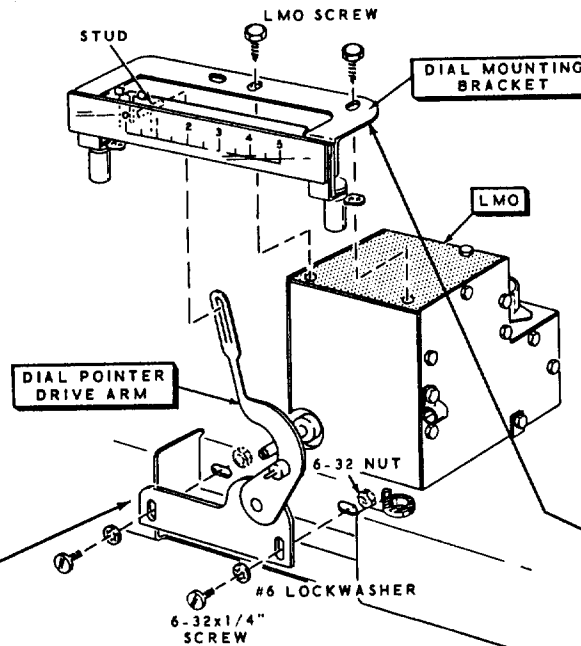

- ( ) Plastic dial window #464-30-1, pilot lamp sockets #434-44, and dial pointer assembly #100-443 to dial mounting bracket #204-553. Use 3-48 x 3/8" flat head hardware. Be sure to position the plastic dial window and dial pointer assembly as shown.

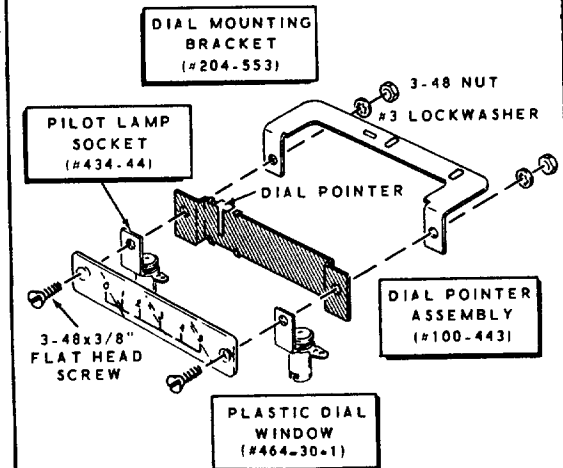

- ( ) Dial mounting bracket to the LMO. Use the two top-front screws of the LMO. Position the stud from the rear of the dial pointer drive arm.

PICTORIAL 3-33

## Dial Mounting - Continued

- ( ) Start an 8-32 x 1/4" setscrew in the threaded hole in the hub of the circular dial, #100-449.

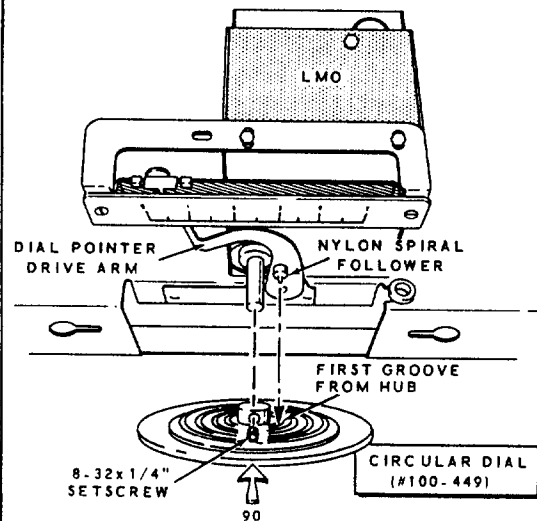

- ( ) Turn the shaft of the LMO fully counterclockwise, against its stop.

- ( ) Position the circular dial on the LMO shaft with the "90" marking straight up, and the nylon spiral follower in the first groove (nearest the hub) of the circular dial.

NOTE: If the nylon spiral follower will not fit into the first groove of the circular dial, loosen the hardware that secures the dial pointer drive arm to the chassis. Then, move the dial pointer drive arm as required. Retighten the hardware.

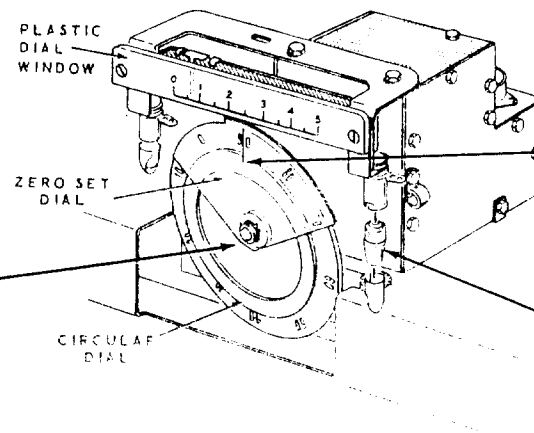
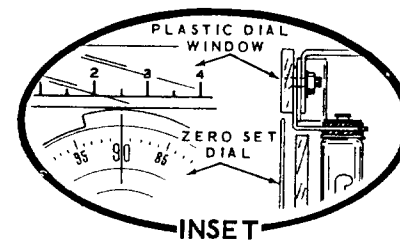

PICTORIAL 3-34

- ( ) Push the circular dial onto the LMO shaft until the tip of the nylon spiral follower is to the bottom of the first groove in the circular dial, then tighten the setscrew.

- ( ) Check to see that the front of the plastic dial window is flush with the zero set dial on the circular dial. If not, loosen the two screws on the top of the LMO and adjust the dial mounting bracket as required.

NOTE: If the zero set dial does not rotate freely under the plastic dial window, bend the dial mounting bracket up to obtain sufficient clearance.

- ( ) Check to see that the "90" marking on the circular dial is directly under the 2-1/2 mark on the plastic dial window when the shaft of the LMO is turned fully counterclockwise. If not, loosen the circular dial setscrew and make the necessary adjustment. Retighten the setscrew. See the inset drawing.

- ( ) Install a #47 pilot lamp and a pilot lamp shield at each of the two pilot lamp sockets. Position the opening of the shield toward the edge of the circular dial.

CAUTION: Be sure the lugs on the pilot lamp sockets do not touch the dial pointer when it is moved to its extreme ends. If the lugs do touch the pointer, twist the lugs away from the pointer until sufficient clearance is obtained.

## DIAL ADJUSTMENT

( ) Rotate the circular dial clockwise from the fully counterclockwise position ("90" marking) to the first zero marking. The dial pointer should be at the zero marking on the plastic dial window. If not, perform one of the following two steps.

( ) 1. If the dial pointer is to the right of the zero marking, loosen the dial pointer drive arm mounting screws and move the dial pointer drive arm base to the right until the dial pointer is at zero. Do not move the dial pointer drive arm base up or down. Retighten the screws.

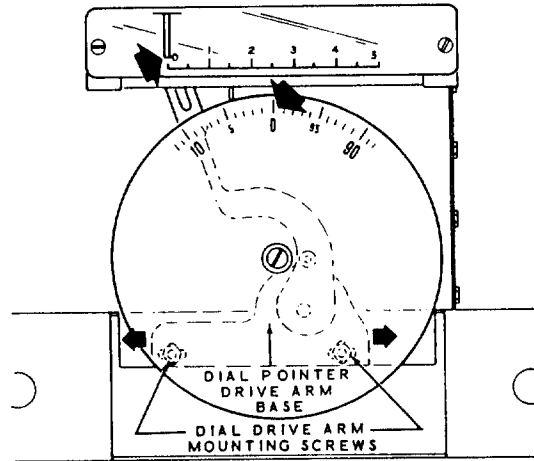

NOTE: TO ADJUST THE SCREWS OF THE DIAL POINTER DRIVE ARM, LOOSEN AND TIGHTEN THE NUTS WITH THE 1/4" OPEN END WRENCH.

( ) 2. If the dial pointer is to the left of the zero marking, loosen the dial pointer drive arm mounting screws, and move the dial pointer drive arm base to the left until the dial pointer is at zero. Do not move the dial pointer drive arm base up or down. Retighten the screws.

PICTORIAL 3-35

## Dial Adjustment - Continued

NOTE: The following adjustment may affect the dial pointer setting at the zero marking. Repeat the entire procedure as many times as necessary to obtain proper dial and pointer calibration. Because the dial pointer is only a turns counter it need not be exactly at a number when the circular dial is at one of its five possible zero settings, however, the following steps should permit fairly close calibration. Rotating the circular dial from the fully counterclockwise position to the fully clockwise position will cause the dial pointer to go to the left of the zero marking and to the right of the "5" marking on the plastic dial window. These adjustments in no way affect frequency calibration, which depends only on the circular dial reading.

- ( ) Rotating the circular dial in a clockwise direction one revolution (zero to zero) should move the dial pointer to the "1" marking on the plastic dial window. Each time the circular dial is rotated one revolution clockwise, the dial pointer should advance one more number on the plastic dial window. After five complete revolutions the dial pointer should be very close to the "5" marking on the plastic dial window. If not, perform one of the following two steps.

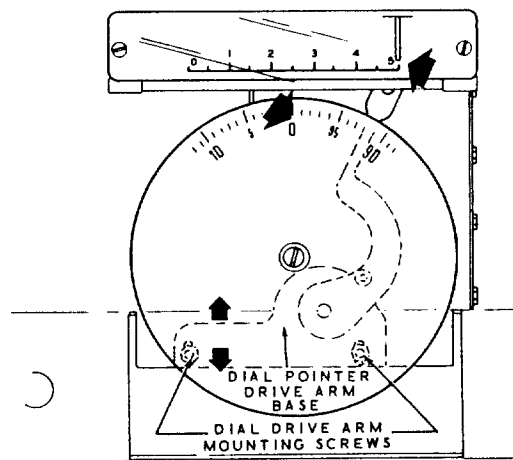

PICTORIAL 3-36

- ( ) 1. If the dial pointer is to the left of the "5" marking, loosen the dial pointer drive arm mounting screws and move the dial pointer drive arm base up until the dial pointer is at the "5" marking. Do not move the dial pointer drive arm base left or right. Retighten the screws.

- ( ) 2. If the dial pointer is to the right of the "5" marking, loosen the dial pointer drive arm mounting screws and move the dial pointer drive arm base down until the dial pointer is at the "5" marking. Do not move the dial pointer drive arm base left or right. Retighten the screws.



## PARTS MOUNTING-FRONT PANEL

( ) Lay a soft cloth on the work area to prevent scratching the front panel.

( ) Switch #63-386 at NA. Use a 3/8" control lockwasher, 3/8" control flat washer, and a 3/8-32 control nut. Position the switch as shown.

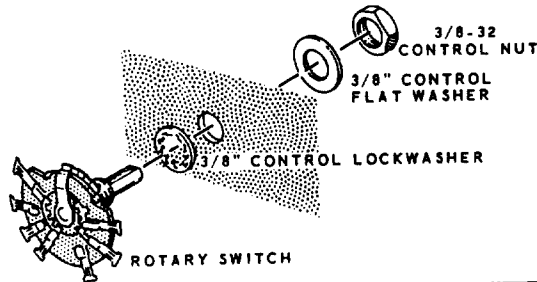

( ) Meter #407-101 at NB with a 2-lug miniature terminal strip at NC. Use the lockwashers and nuts supplied with the meter.

( ) Remove the shorting wire from between the meter terminals.

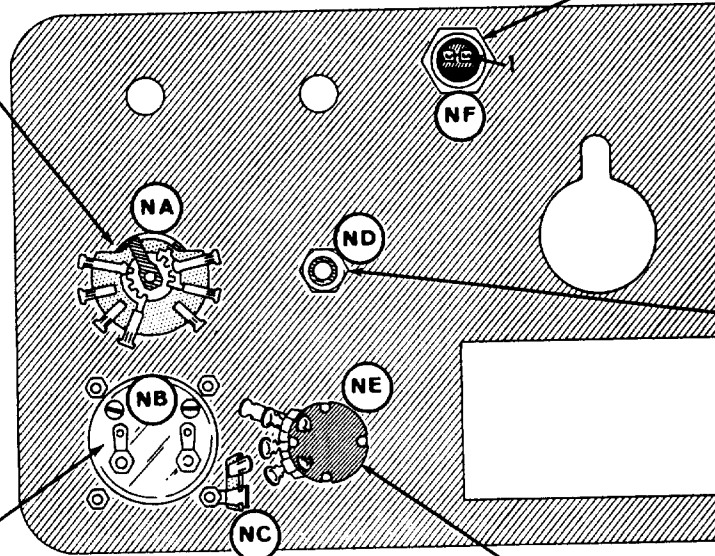
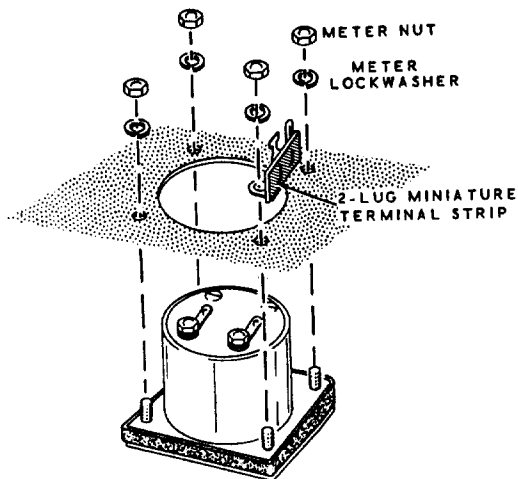

PICTORIAL 3-37

( ) Female connector at NF. Use the lockwasher and nut supplied with the connector. Position lug 1 as shown. Before mounting the connector, be sure the small screw that holds the connector together is tight. Place some glue or fingernail polish over the head of this screw to keep it from becoming loose.

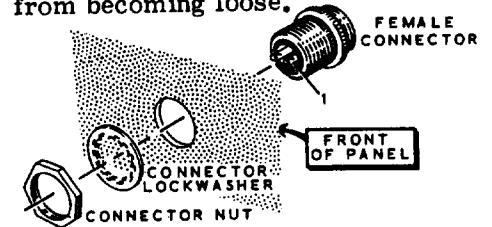

( ) Threaded bushing at ND. Use a 3/8" control lockwasher, 3/8" control flat washer, and a 3/8-32 control nut.

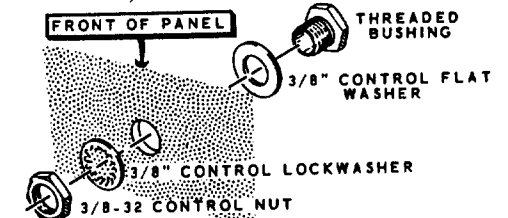

( ) 10 K $\Omega$  control with push-pull switch, #19-60, at NE. Use a 3/8" control solder lug, 3/8" control flat washer, and a 3/8-32 control nut. Position the solder lug and control as shown. Bend the solder lug as shown.

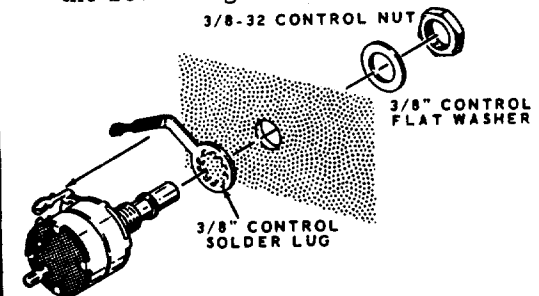

Parts Mounting-Front Panel - Continued

- ( ) 4-lug phone jack at NH. Use a 3/8" control lockwasher, 3/8" control flat washer, and a 3/8-32 control nut.

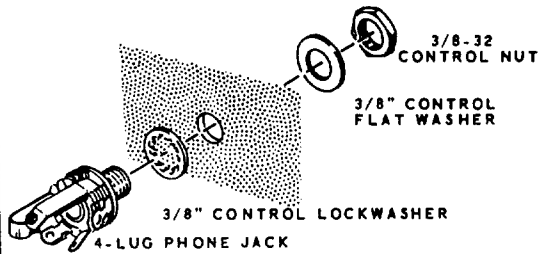

- ( ) Dial escutcheon to the front panel; use drive shaft bushing assembly #455-42. Position the tabs at the top of the escutcheon inside the front panel. Do not tighten the nut at this time. Be sure the bushing is inserted from inside the front panel. It may be necessary to sand off any excess paint from the top inside edge of the panel to allow installation of the escutcheon.

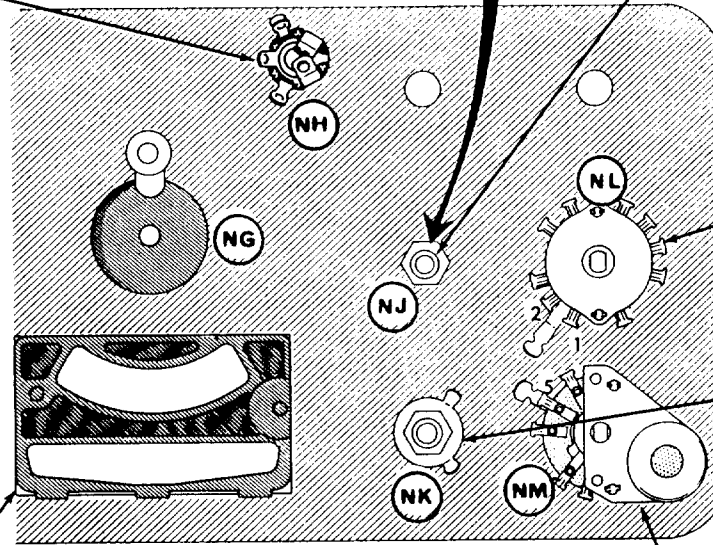
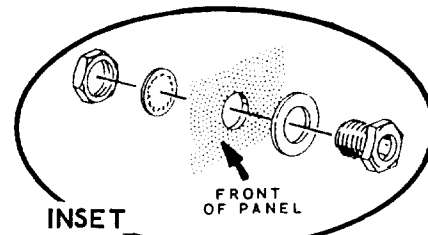
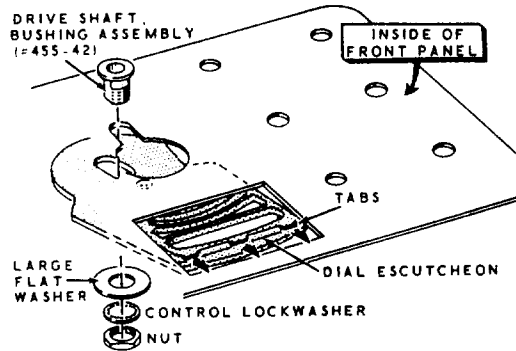

PICTORIAL 3-38

- ( ) Threaded bushing at NJ. Use a 3/8" control lockwasher, 3/8" control flat washer, and a 3/8-32 control nut.

- ( ) Switch #63-385 at NL. Use a 3/8" control solder lug, 3/8" control flat washer, and a 3/8-32 control nut. Position the solder lug and switch as shown.

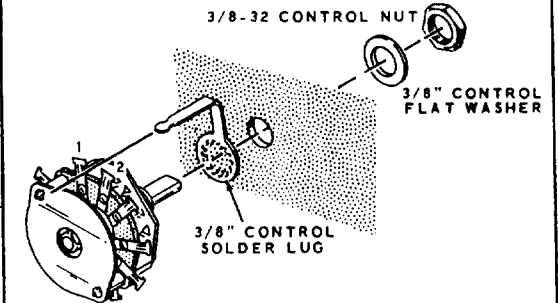

- ( ) Threaded bushing and 180 degree rotational stop at NK. Use two 3/8" control lockwashers, 3/8" flat washer, and a 3/8-32 control nut. Position the rotational stop as shown.

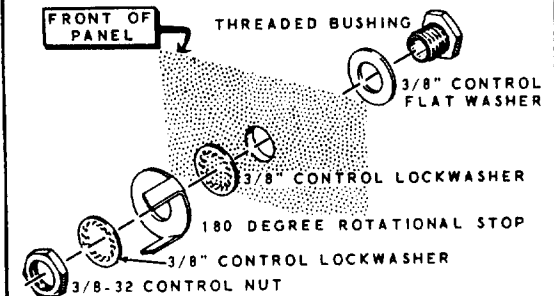

- ( ) Switch #63-383 at NM. Use a 3/8" control solder lug, a 3/8" control flat washer, and a 3/8-32 control nut. Position the solder lug and switch as shown. Bend the control solder lug against lug 5 of the switch.

## WIRING-FRONT PANEL

**CAUTION:** When soldering in the following steps, be careful not to touch the dial window or circular dial with the soldering iron.

( ) Lead from pilot lamp socket, #434-85, to HB1 (NS).

( ) Lead from 14  $\mu\mu\text{f}$  capacitor to HA1 (S-1).

( ) Lead from 14  $\mu\mu\text{f}$  capacitor to HA2 (S-1).

( ) Lead from 14  $\mu\mu\text{f}$  capacitor to HA3 (S-1).

Save the wires cut off in the next two steps, they will be used later.

( ) Cut the brn wire from BO#15 even with the end of the grn wires.

( ) Cut the yel wire from BO#15 even with the end of the wht wire.

Connect the wires from BO#15 as follows:

( ) Brn to HB1 (S-2).

( ) Blu-wht NA7 (S-1).

( ) Gry to NA6 (S-1).

( ) Wht to NA1 (S-1).

( ) Blk-wht to NA2 (S-1).

( ) Viol-wht to NA3 (S-1).

( ) Org-yel-wht to NA4 (S-1).

( ) 3-1/2" yel wire from NB1 (S-1) to NA8 (S-1).

( ) One end of a 4-1/4" brn wire to HB2 (S-1). The other end will be connected later.

Connect the wires from BO#15 as follows:

( ) Yel to NB2 (S-1).

( ) Both grn to NE5 (NS).

( ) Org to NE1 (S-1).

( ) Solder NE3 to the control solder lug (S-1).

( ) .2  $\mu\text{fd}$  resin from NC1 (NS) to NE4 (S-1). Note banded end.

( ) 5.6 megohm (grn-blu-grn) between NE2 (NS) and NE5 (NS).

( ) 100 K $\Omega$  (brn-blk-yel) from NC1 (NS) to NE2 (S-2).

( ) .02  $\mu\text{fd}$  disc from NC1 (S-3) to NE5 (S-4).

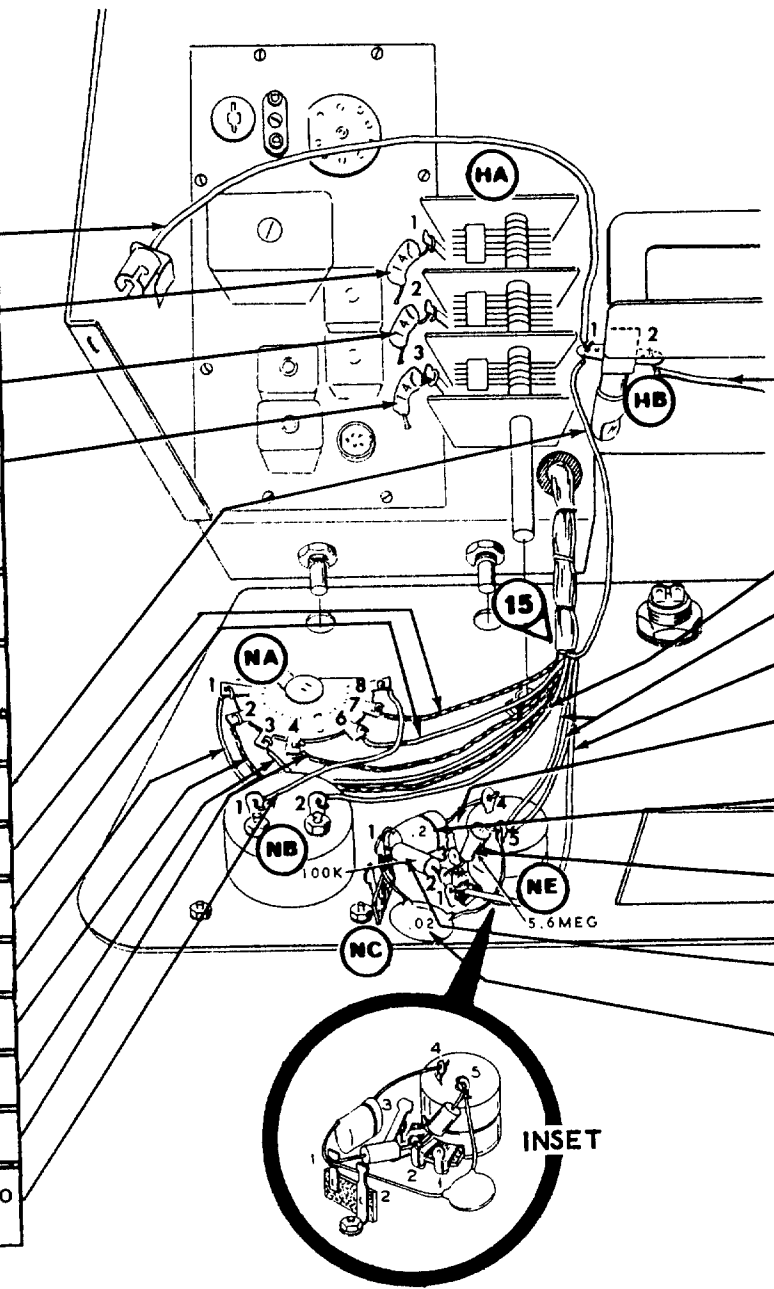

PICTORIAL 3-39

- ( ) Free end of brn wire from HB to MG1 (S-1).
- ( ) Position the wires from BO#17 against the front panel as shown.
- Connect the cables from BO#4 to switch NL as follows:
- ( ) Blk; inner lead to lug 3 (S-1), and the shield to the solder lug (NS).
- ( ) Blue; inner lead to lug 2 (S-1), and the shield to the solder lug (NS).
- ( ) Yel; inner lead to lug 1 (S-1), and the shield to the solder lug (NS).
- ( ) Coaxial cable coming from LMO; inner lead to NL12 (S-1), and the shield to the solder lug (S-4).
- ( ) One end of a 2-1/2" brn wire to NM5 (NS). The other end will be connected later.
- ( ) Connect the small black wire from BO#17 to NM5 (S-2). Be sure the solder lug is soldered to NM5.
- ( ) Cut off the red wire from BO#17 even with the end of the Blu wire. Save this wire for later use.

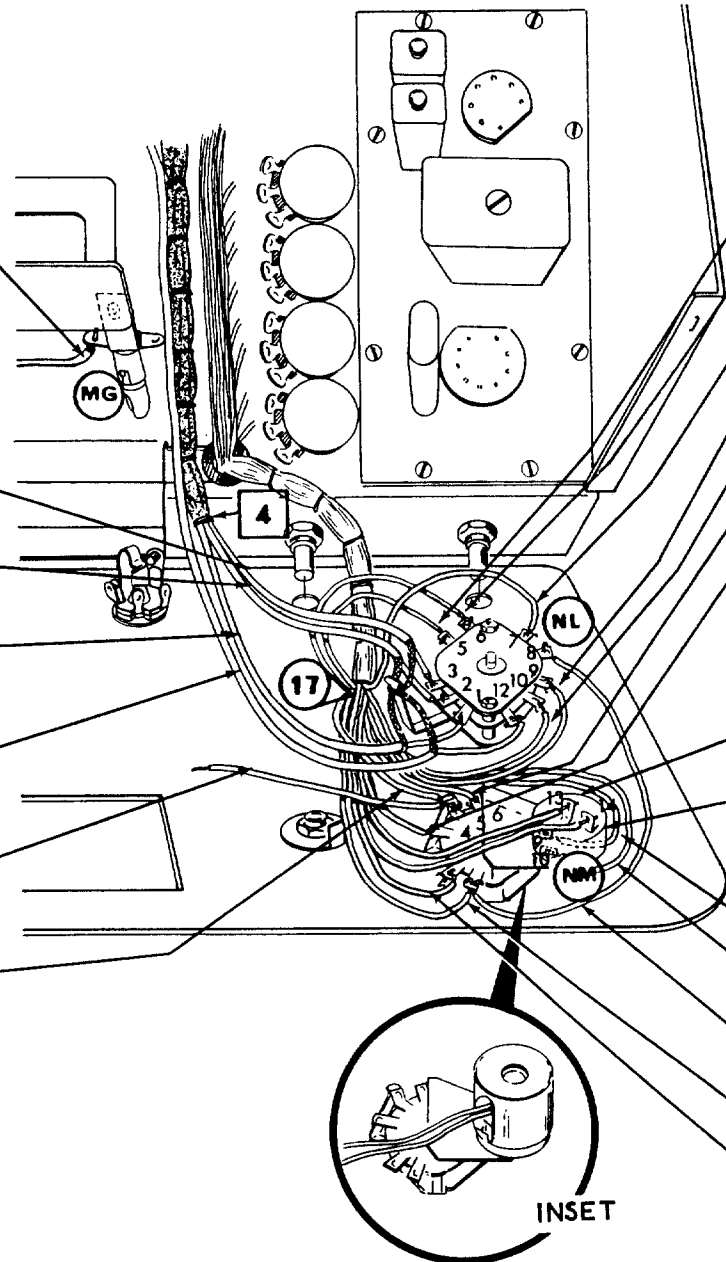

PICTORIAL 3-40

- Connect the wires from BO#17 as follows:
- ( ) Org-yel-wht to NL5 (S-1).
  - ( ) Red-wht to NL6 (S-1).
  - ( ) Viol to NL7 (S-1).
  - ( ) Gry-wht to NL9 (S-1).
  - ( ) Org-wht to NL10 (S-1).
  - ( ) Wht to NM6 (S-1).
  - ( ) Yel-wht to NM4 (S-1).
- Be very careful in the next step, when removing the switch cover, that you do not pry off the switch.
- ( ) Remove the switch cover from NM, using the blade of a screwdriver.
  - ( ) Either large blk to NM13 (S-1).
  - ( ) Other large blk to NM14 (S-1).
  - ( ) Replace the switch cover on NM. Be careful not to bend the switch frame. See the inset drawing.
  - ( ) Grn-wht to NM9 (S-1).
  - ( ) Grn to NM10 (S-1).
  - ( ) 5-1/2" red wire from NL8 (S-1) to NM1 (NS).
  - ( ) Red to NM1 (S-2).
  - ( ) Blu to NM2 (S-1).
  - ( ) Check all connections on the front panel to see that they are soldered.

## FRONT PANEL MOUNTING

( ) Remove the control nuts and control flat washers at FJ, BF, BE, and the threaded bushing and control flat washer at FH.

( ) Snap the zero set drive pulley (small shaft) onto the zero set dial. Position the pulley and dial as shown.

( ) See inset drawing #1 to open the silicone grease pod.

( ) Apply a very thin layer of silicone grease to the shaft of the dial drive pulley (large shaft). Be very careful not to get grease on the pulley or any other part of the Transceiver.

( ) Slide the shaft of the dial drive pulley into the dial drive bushing. Slide the bushing up as far as possible.

( ) Carefully position the front panel on the chassis. Place the zero set drive shaft through the small hole in the upper right-hand corner of the escutcheon. Be sure no wires are pinched between the front panel and the chassis, and do not catch the switch lugs on the flanges at the sides of the chassis.

( ) Replace the control nuts at FJ, BF, BE, and the threaded bushing and control flat washer at FH. Do not tighten the hardware at this time.

NOTE: The following adjustment of the front panel is critical and must be done carefully to obtain smooth operation of the dial mechanism.

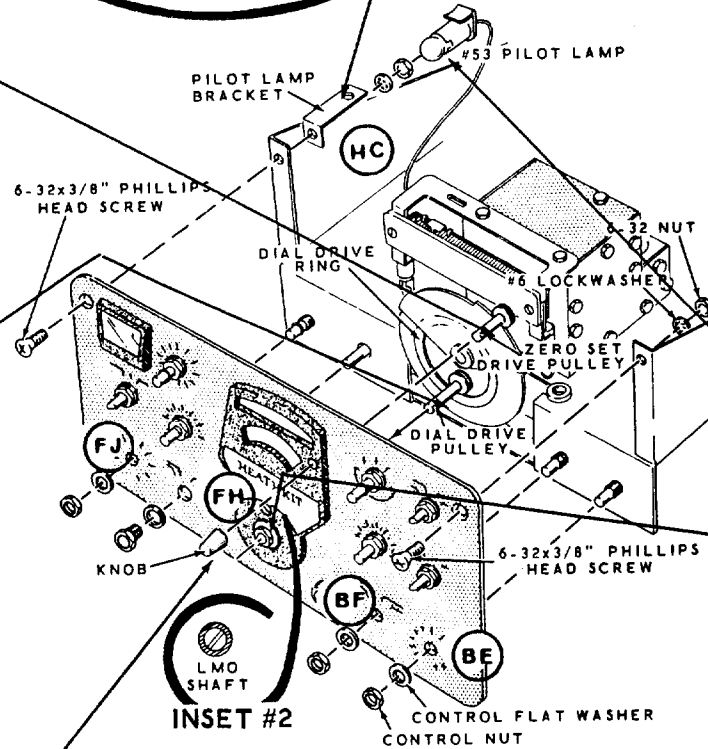
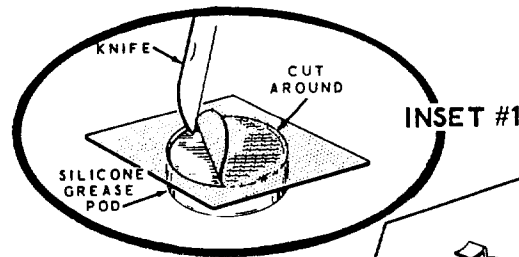

PICTORIAL 3-41

( ) Start 6-32 x 3/8" phillips head hardware at the top corners of the front panel, with the pilot lamp bracket at HC. Do not tighten the hardware at this time.

( ) By carefully moving the front panel, align the small hole in the center of the escutcheon with the end of the LMO shaft. See inset drawing #2. With the bottom edge of the front panel parallel to an imaginary horizontal line through the end of the LMO shaft, tighten the control nuts at FJ, BF, BE, and the bushing at FH.

( ) Tighten the hardware at the top corners of the front panel. Position pilot lamp bracket HC as shown.

( ) Place a #53 pilot lamp in the loose pilot lamp socket, and clip the socket to pilot lamp bracket HC.

( ) Push the dial drive bushing down so the dial pulley engages with the circular dial drive ring; there should be just enough pressure to rotate the circular dial without slippage. Tighten the dial drive bushing. The amount of torque required to turn the circular dial can be adjusted by moving the dial drive bushing up or down.

( ) Push the zero set drive pulley flush with the inside of the dial escutcheon, then install the 7/16" aluminum knob on the zero set drive pulley shaft. Use a 4-40 x 1/8" setscrew. Be sure the zero set dial does not rub against the circular dial plate. They should be separated by at least 1/64".

# FINAL WIRING-CHASSIS BOTTOM

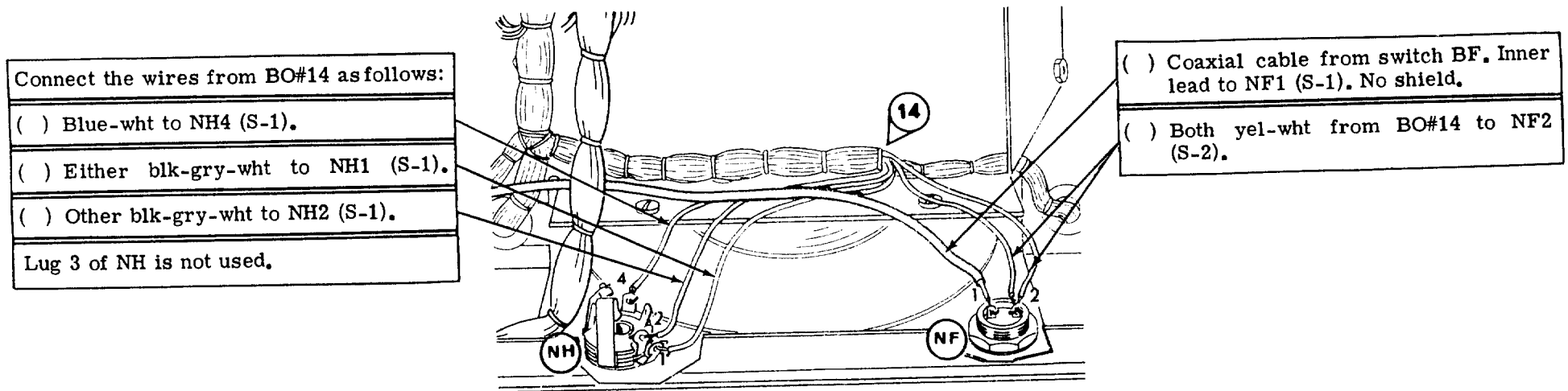

PICTORIAL 3-42

## DRIVE SHAFT INSTALLATION

- ( ) Loosen the front setscrew in the shaft coupling at LE. Be sure the split bushing is in the shaft coupling.
- ( ) Pass the end of the 9-3/8" long shaft through the bushing at NK.
- ( ) Place the dial bushing and the dial pulley, #100-458, on the 9-3/8" long shaft. Position as shown. Start an 8-32 x 7/16" setscrew in the dial bushing, and an 8-32 x 1/4" setscrew in the dial pulley.
- ( ) Fit the end of the 9-3/8" long shaft through the hole in the final shield and into the shaft bushing at LE as far as possible. Tighten the front setscrew in the shaft coupling.
- ( ) Pass the end of the 8" long tubular shaft through bushing NK, the dial bushing, the dial pulley, and against the final shield.

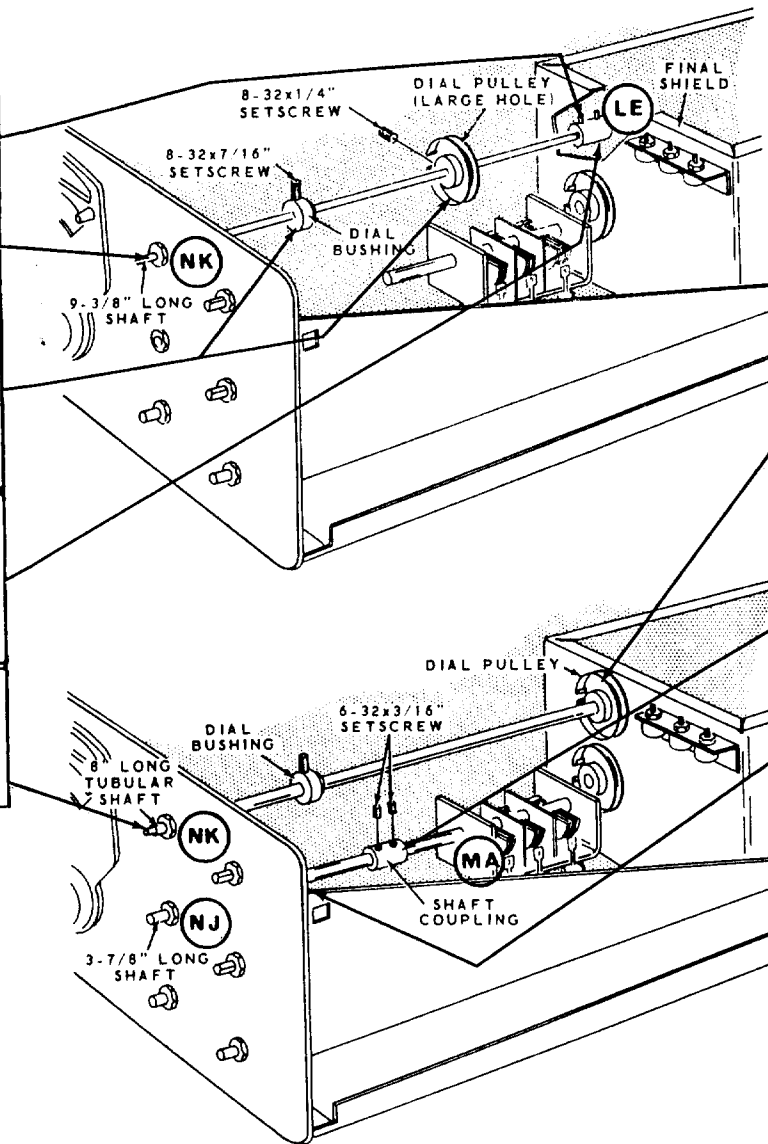

- ( ) Position the top dial pulley directly over the lower dial pulley and tighten the setscrew.
- ( ) Start two 6-32 x 3/16" setscrews in a shaft coupling.
- ( ) Slide the shaft coupling half-way on the shaft of capacitor MA, and tighten the rear setscrew.
- ( ) Pass the end of the 3-7/8" long shaft through bushing NJ and into the shaft of coupling on capacitor MA as far as possible. Tighten the front setscrew in the shaft coupling. It may be necessary to loosen the mounting screws of capacitor MA to obtain proper shaft alignment in bushing NJ. Retighten the screws after proper alignment is achieved.

PICTORIAL 3-43

Driver Shaft Installation - Continued

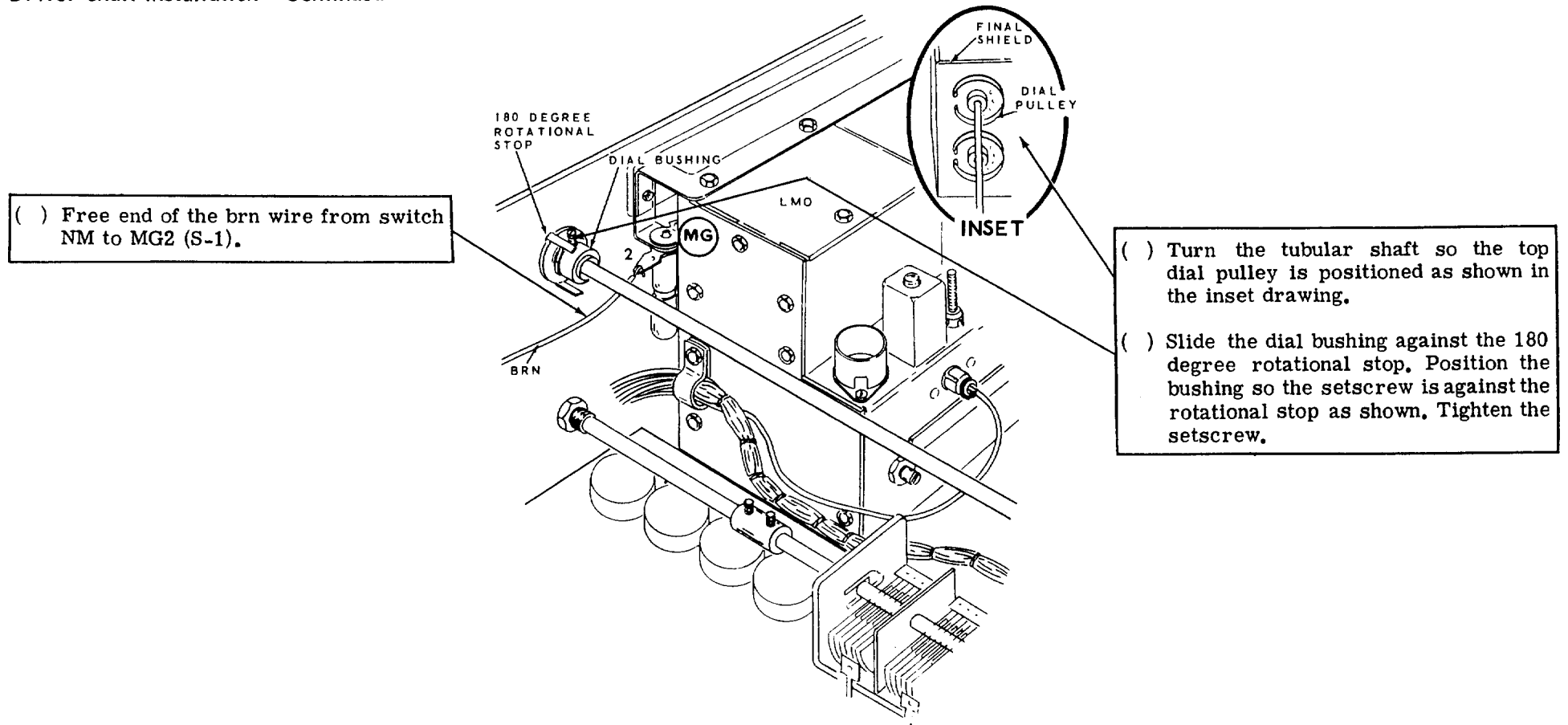

PICTORIAL 3-44



## DIAL STRINGING

- ( ) Turn the dial pulley LF to the position shown. The plates of this capacitor should now be fully opened.
- ( ) Tie a loop in one end of the dial cord. Hook the loop over the tab of dial pulley LE.
- ( ) String the dial cord by following the numbers. Make one complete loop around the tab (at 6) of dial pulley LF.

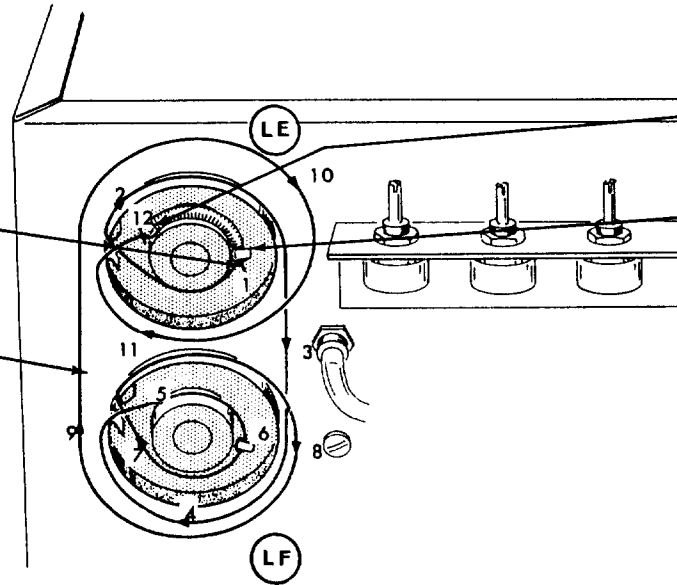

- ( ) At 12, tie the dial cord to one end of the dial cord spring. Cut off the excess dial cord.
- ( ) Open the loop to form a hook in the other end of the dial cord spring. Hook the end of the dial cord spring into the hole directly behind the tab of dial pulley LE.
- ( ) Rotate the tubular shaft from one extreme to the other to see that the dial pulleys operate together. If not, make any necessary adjustments.

PICTORIAL 3-45

## KNOB INSTALLATION

NOTE: Before installing the knobs in the following steps, turn all control and switch shafts fully counterclockwise. See that all variable capacitor plates are fully meshed (closed).

( ) 2-1/2" knob on the LMO shaft. Use two 8-32 x 1/4" setscrews.

NOTE: When installing the remaining round knobs, position the pointer at the position indicated by the arrow. If the knob pointers do not correspond to the dial markings, loosen the control or switch hardware and reposition them as required.

( ) 1-1/8" knob, using a 8-32 x 1/4" setscrew.

( ) 1-1/8" knob, using a 8-32 x 1/4" setscrew.

( ) 1-1/8" knob, using a 8-32 x 1/4" setscrew.

( ) 1-1/8" knob, using a 8-32 x 1/4" setscrew. The setscrew does not tighten against the flat of this control shaft.

( ) 1-1/8" knob, using a 8-32 x 1/4" setscrew.

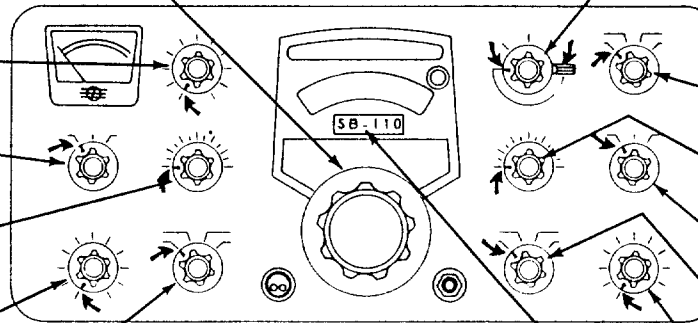

PICTORIAL 3-46

( ) Lever knob on the tubular shaft, using a 4-40 x 1/8" setscrew. Position the lever as shown with the capacitor plates fully meshed.

( ) 1-1/8" knob with a split bushing. Use a 8-32 x 1/4" setscrew. The capacitor plates should be fully meshed.

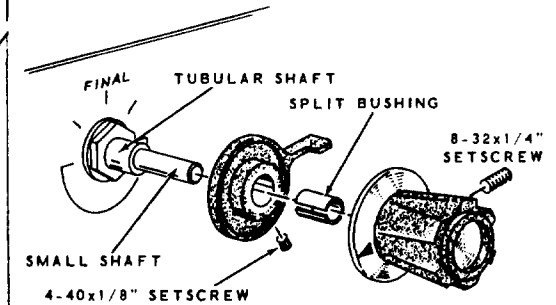

( ) 1-1/8" knob, using a 8-32 x 1/4" setscrew.

( ) 1-1/8" knob, using a 8-32 x 1/4" setscrew.

( ) 1-1/8" knob, using a 8-32 x 1/4" setscrew.

( ) 1-1/8" knob, using a 8-32 x 1/4" setscrew.

( ) 1-1/8" knob, using a 8-32 x 1/4" setscrew.

( ) Remove the protective backing from the nameplate "SB-110" and press it firmly in place in the indentation of the dial escutcheon.

This completes the wiring of the Transceiver except for the two resistors in section A and the resistor left off the receiver RF circuit board. These connections will be made later.

## CONTROL FUNCTIONS

Read through the following paragraphs carefully. A knowledge of how all the controls operate is essential for many of the remaining sections of this Manual.

### FRONT PANEL CONTROLS

#### Main Tuning

The Main Tuning (LMO) has two dials. The lower, circular, dial is divided into one-hundred 1 kc segments.

The upper dial is divided into five 100 kc segments. The distances between the numbers are each equal to one revolution of the circular dial, or 100 kc. The smaller segments are 50 kc, or one-half revolution of the circular dial.

There are three different numbers that must be added together to determine the frequency of the Transceiver. These are the BAND switch setting in megacycles, the upper dial pointer setting in hundreds of kilocycles, and the circular dial setting in kilocycles.

For example: if the BAND switch is set to 50.0, the upper dial pointer is between 2 and 3, and the circular dial is at 53, the frequency is 50.253 mc. If the BAND switch is set at 51.5, the upper dial pointer between 3 and 4, and the circular dial is at 12, the frequency is 51.812 mc.

#### Zero Set Dial

After the Main Tuning dial is adjusted for zero beat with the 100 KC calibrate signal, the Zero Set Dial hairline should be set over the zero mark on the circular dial. This should be done each time the BAND switch is changed from one band to another.

#### Meter (See Figure 1-12 on Page 105)

In the receive mode of operation, the meter is connected as an S meter that reads from 0 to 60 over S-9, regardless of the setting of the METER switch.

In the transmit mode, the METER switch selects one of the following three quantities to be read on the meter; final amplifier Plate current, Automatic Level Control voltage, and Relative (output) Power.

#### AF Gain

The AF GAIN control adjusts the audio output level of the receiver. It is adjusted to the desired listening level. Pulling "out" on this control turns on the noise limiter.

#### RF Gain

The RF GAIN control adjusts the receiver sensitivity. This control should be in the full clockwise position for most applications. With this control in the "in" position, the AGC circuit operates at a fast decay time constant. When the control is pulled "out," the AGC circuit operates at a slow decay time constant. For best results in the SSB mode of operation, this control should be in the "out" position.

#### Preselector

This control is used to peak the RF amplifier input tuned circuits. This adjustment need only be made when the BAND switch is turned to a different position.

#### Band

This switch selects any 500 kc portion of the 6-meter amateur band in the following four steps: 50.0 to 50.5, 50.5 to 51.0, 51.0 to 51.5, and 51.5 to 52.0. Crystals are supplied for each of these frequency ranges.

#### Final

The round knob at this location is the FINAL Tuning control. After the Main Tuning knob has been set to the desired operating frequency, and the Mode switch set to the Tune position, this control is adjusted for maximum (Relative Power) meter indication to tune the transmitter for maximum output.

The lever arm at this location is the FINAL Loading control. This lever is also tuned until a maximum (Relative Power) indication is shown on the meter. At this point a correct impedance match is obtained between the antenna and final amplifier circuits.

#### Driver

This control peaks the 2nd Transmitter Mixer and Driver stages for maximum output at the frequency selected on the Main Tuning dial.

#### Mode

This switch selects either the Tune, LSB, USB, or CW mode of operation.

#### Function

This switch turns the Transceiver on and off. In the PTT position, the Transceiver is changed from receive to transmit operation by the push-to-talk switch in the microphone.

In the VOX (voice-operated-transmit) position, the Transceiver is changed from receive to transmit operation when the operator talks into the microphone, or when the CW key is depressed if the Mode switch is in the CW position.

In the CAL position, the 100 kc crystal oscillator signal can be used to calibrate the Main Tuning dial at 100 kc intervals.

#### Oscillator Mode

In the LMO position of this switch, the linear master oscillator is used (Main Tuning control) for variable frequency tuning of the transmitter and receiver.

In AUX T position, the frequency of the receiver section is controlled by the Transceiver LMO, and the transmitter section frequency is determined by the crystal used in crystal oscillator V3B (crystal not supplied).

In the XTAL position the frequencies of both the receiver and transmitter sections are determined by the crystal in crystal oscillator V3B.

#### MIC/CW Level

When the Mode switch is in the LSB or USB positions, this control determines the amount of audio drive to the balanced modulator. It has sufficient range to permit adjustment for any high level crystal microphone or low level dynamic microphone.

With the Mode switch in the Tune or CW positions, this control will adjust the carrier level output of the transmitter.

#### MIC (Microphone)

This 2-terminal socket uses its shield as the third conductor. The audio input circuit is designed to operate with a high impedance microphone. It also has provisions for push-to-talk operation.

#### Phones

High impedance headphones can be connected to this jack. The speaker is automatically disconnected when the headphone plug is inserted.

### CHASSIS CONTROLS

#### Antenna

This switch makes it possible to use a linear amplifier which does not have a built-in antenna change-over relay.

#### ATG (Anti-Trip Gain)

This control, when properly adjusted, keeps the received signal (at the speaker) from turning the transmitter on by going back through the microphone and VOX circuit.

#### Delay

The DELAY control adjusts the length of time the transmitter stays on after the operator stops talking (when the VOX circuit is used). Proper setting of this control eliminates the repeated keying of the transmitter at the beginning of each word.

## VOX

The VOX control adjusts the amount of audio signal that is coupled from the microphone to the VOX amplifier. The output of the VOX amplifier energizes the VOX relay, and places the transmitter "on-the-air" when the operator talks into the microphone.

### Head Phone Level

This control is adjusted for the desired audio output level at the headphones.

## Relative Power Adjust

This control is used to set the meter sensitivity when the METER switch is in the REL PWR position.

### Side Tone Level

When the MODE switch is in the CW position and when the CW key is depressed, the Side Tone Level control adjusts the side tone audio signal to the desired monitoring level from the speaker.

## PRELIMINARY CHECKS

Before beginning the Preliminary checks, make sure that all connections are soldered, except for the following: The free leads of the 6800  $\Omega$  and 100  $\Omega$  1 watt resistors in section A of the chassis; and the 33 K $\Omega$  2 watt resistor left off of the Receiver RF circuit board.

Cut off any excess wire ends extending from the lettered sides of the circuit boards, which may touch other component connections or transformer cans.

Shake out any solder splashes or wire clippings. Position all cables and wires as shown in Figures 3-7 and 3-8 at the rear of the Manual. The two cables may be taped to the support rail on the right side of the chassis to keep them in place.

The resistance checks should be made as described in this section before you apply power to the Transceiver. The purpose of these checks is to make sure there are no short circuits or leakage paths present, since these could seriously damage the Transceiver. If your resistance readings vary more than  $\pm 20\%$  from those listed, carefully recheck your work.

- ( ) Check the mechanical zero of the panel meter. If necessary, adjust the screw in the front of the meter until the pointer is on zero.

## CONTROL SETTINGS

Preset the front panel controls as follows:

METER - PLATE.  
AF GAIN - 10 o'clock position, with the control pushed-in.  
RF GAIN - fully clockwise, with the control pushed-in.  
PRESELECTOR - 10 o'clock position.  
BAND - 50.0.  
MAIN TUNING DIAL (LMO) - 50.10 (upper dial pointer on 1 and the circular dial on 0).  
FINAL (round knob) - 10 o'clock position.  
LOADING (lever knob) - over the 50  $\Omega$  marking on the front panel.  
DRIVER - 10 o'clock position.  
MODE - USB.  
FUNCTION - OFF.  
OSC MODE - LMO.  
MIC/CW LEVEL - fully counterclockwise.

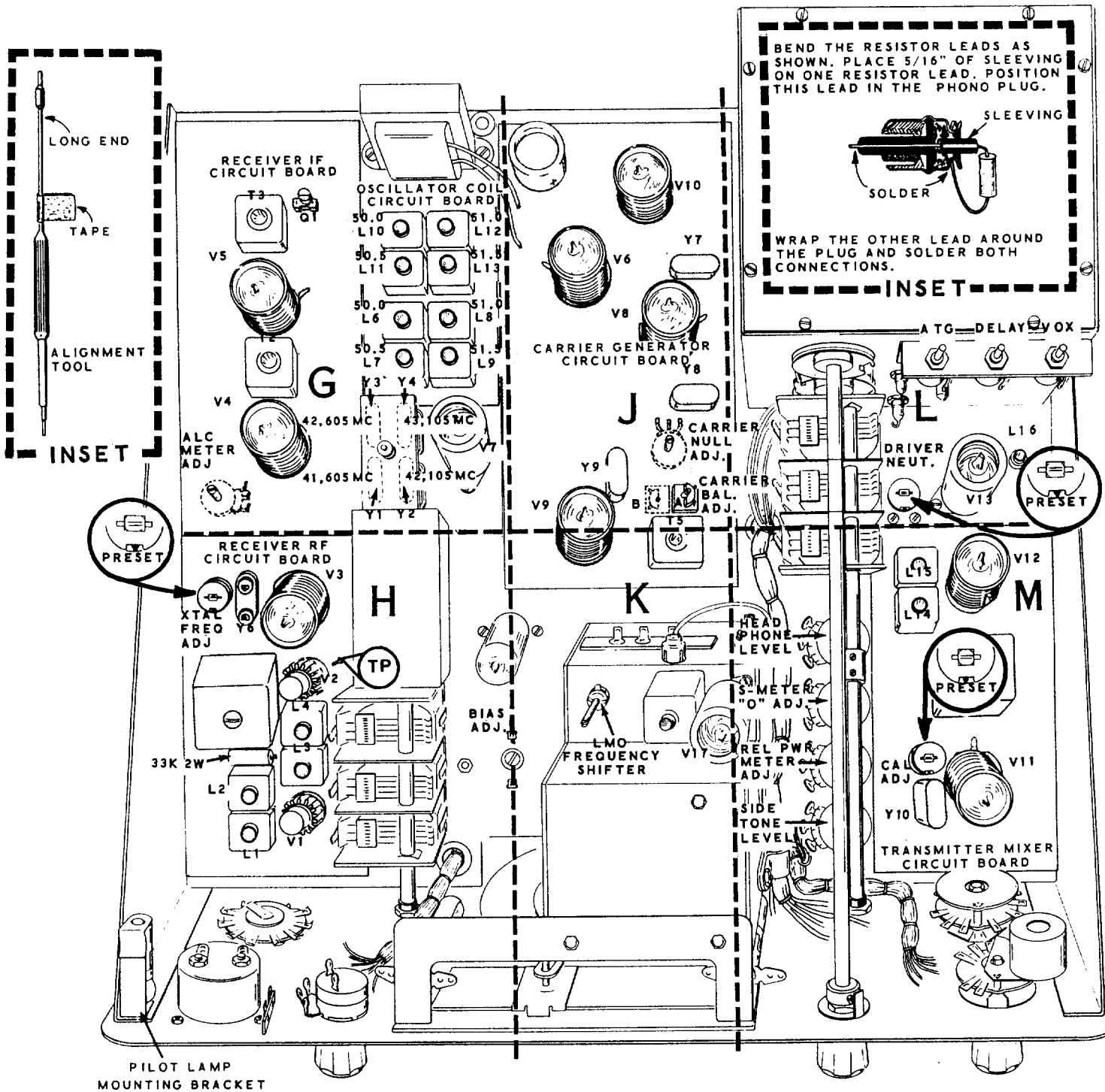

Figure 1-5

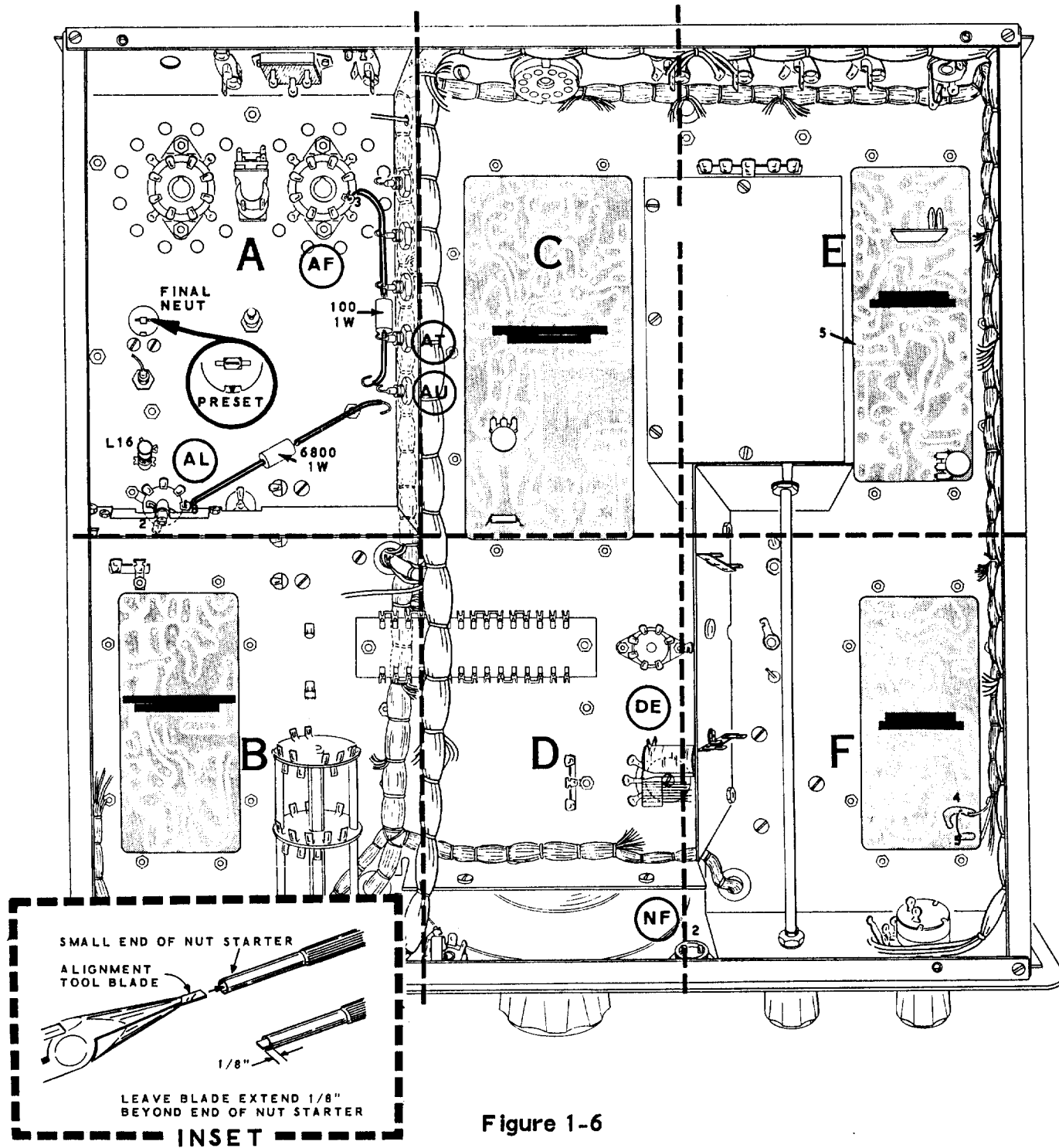

Figure 1-6

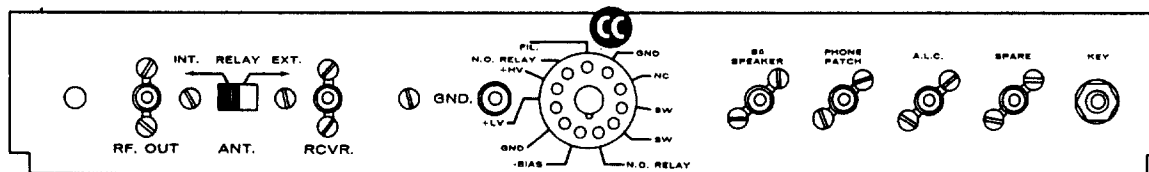

Figure 1-1

Referring to Figures 1-5 and 1-6 preset the circuit board and chassis controls as follows:

- XTAL FREQ ADJ - position the arrow as shown (section H).
- ALC METER ADJ - center of range (section G).
- BIAS ADJ - fully counterclockwise (section H).
- CARRIER BAL ADJ - capacitor plates fully meshed (section J).
- CARRIER NULL ADJ - center of range (section J).
- SIDE TONE LEVEL - center of range (section M).
- REL PWR METER ADJ - fully clockwise (section M).
- S-METER "0" ADJ - center of range (section M).
- HEADPHONE LEVEL - center of range (section M).
- ATG (fully counterclockwise (section L).
- DELAY - fully counterclockwise (section L).
- VOX - fully counterclockwise (section L).
- CAL ADJ - position arrow as shown (section M).
- DRIVER NEUT - position arrow as shown (section L).
- FINAL NEUT - position arrow as shown (adjust from bottom of chassis, section A).
- ANT RELAY switch - INT position (located on rear of chassis).

CAUTION: Be sure the loose ends of the 100  $\Omega$  and 6800  $\Omega$  1 watt resistors in section A are clear of the chassis and any connections.

## RESISTANCE CHECKS

Refer to Figure 1-1 for the following checks.

An ohmmeter will be used for the following checks. One test lead will be connected to the chassis (ground) for most of the checks. The other test lead will be connected to various pins of power plug CC on the rear of the chassis.

The various switch positions for each check are listed in the following chart. Under the "Relay DE" heading are the letters NE and E. "NE" means the relay is not energized. "E" means the relay is energized. The relay can be energized mechanically by pushing on the end of the relay actuator with your finger.

- ( ) Carefully remove the 6146 tubes from sockets V14 and V15. Be sure the anode leads are not touching the chassis.



OHMMETER TEST POINTS		FUNCTION SWITCH	MODE SWITCH	RELAY DE	RESISTANCE IN OHMS
COMMON LEAD	OTHER LEAD (Power Plug Pin)				
CHASSIS GND	1 (BIAS)	OFF	USB	NE	32 K
"	"	"	CW	"	32 K
"	"	"	TUNE	"	32 K
"	"	"	LSB	"	34 K
"	"	PTT	"	"	20 K
"	"	"	TUNE	"	32 K
"	"	"	USB	"	18 K
"	"	"	CW	"	32 K
"	"	VOX	"	"	32 K
"	"	"	USB	"	32 K
"	"	"	LSB	"	34 K
"	"	"	TUNE	"	32 K
"	"	CAL	"	"	32 K
"	"	"	LSB	"	34 K
"	"	"	USB	"	32 K
"	"	"	CW	"	32 K
"	"	PTT	"	E	16 K
"	"	"	USB	E	12 K
"	"	VOX	"	E	16 K

OHMMETER TEST POINTS		FUNCTION SWITCH	MODE SWITCH	RELAY DE	RESISTANCE IN OHMS
COMMON LEAD	OTHER LEAD (Power Plug Pin)				
CHASSIS GND	2 (GND)	-	-	-	0
"	3 (LV)	OFF	USB	NE	65 K
"	"	"	"	E	18 K
"	4 (HV)	-	-	-	INF
"	"	Temporarily short one of the anode leads of V 14 or V 15 to the chassis.			6
"	5 (N.O. RELAY)	-	-	-	INF
"	6 (FIL)	Remove the pilot lamp socket from the pilot lamp mounting bracket.			20*
"	"	Replace the pilot lamp socket on the bracket.			10*
"	7 (GND)	-	-	-	0
"	8 (NC)	-	-	-	INF
"	9 (SW)	-	-	-	INF
"	10 (SW)	-	-	-	INF
"	11 (N.O. RELAY)	-	-	-	INF
Power Plug Pin 9 (SW)	10 (SW)	OFF	-	-	INF
"	"	PTT	-	-	0

\*These readings can vary depending on the type of instrument used.

This completes the Preliminary Checks. If any incorrect resistance readings were obtained ( $\pm 20\%$  from the listed value) correct the condition before proceeding.

Preset the controls as outlined on Page 81.

## TUBE AND CRYSTAL INSTALLATION

Refer to Figure 1-5 (fold-out from Page 82) for the following steps.

- ( ) Referring to Figure 1-2, install a heat sink on each of the 6DS4 nuvistors. Place a 6-32 nut in the large end of the nut starter. Slide a heat sink on the small end of the nut starter and down over the large end of the nut starter onto the 6DS4 nuvistors.
- ( ) Install the 6DS4 nuvistors in the sockets at V1 and V2. Position the wide locating tab of the nuvistors into the wide openings of the sockets.
- ( ) Replace the tube (6BZ6) and tube shield previously removed from the LMO.
- ( ) Install the remaining tubes (including the 6146 tubes) into their sockets, as identified on the circuit boards and chassis. The 6AZ8 tube (#411-218) with the painted tip must be installed in tube socket V5. Do not install the tube shields at this time.

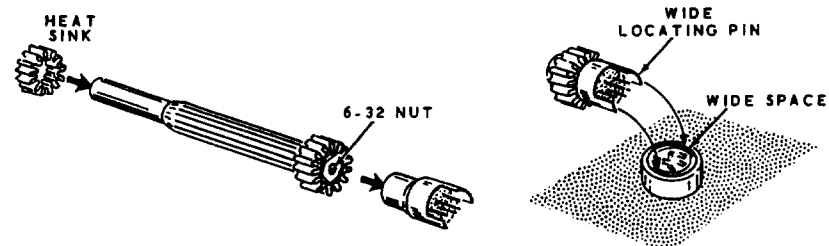

Figure 1-2

NOTE: If IF tubes V4 or V5 are replaced, the settings of the S-Meter "0" Adj control, and IF transformers T2 and T3, should be rechecked. Also, if the 6146 tubes are replaced, the neutralizing procedure should be repeated.

- ( ) Install the four crystals in sockets Y1 through Y4 on the chassis.
- ( ) Install the crystal retaining plate on the top of the crystals with a 6-32 knurled nut.

Refer to the Special Crystal Considerations section of the Manual (Page 95) for the crystals that may be used in crystal socket Y6 on the receiver RF circuit board.

## POWER SUPPLY CONNECTIONS

The Transceiver was designed to operate with the Heathkit Models HP-13A (12 VDC primary power source) and HP-23A (117 V AC primary power source) Power Supplies. The following information will help you wire the 11-pin power socket (supplied with the Transceiver) to the power cable of either of these Power Supplies.

### HEATHKIT HP-13 POWER SUPPLY CONNECTIONS

**CAUTION:** Be sure the alternate connection in the low voltage DC circuit of the HP-13A Power Supply is connected for the +250 volt output as outlined in the HP-13A Power Supply Manual.

**NOTE:** If the Heathkit mobile mount is being used, make the power supply connections as directed in the SBA-100-1 Manual.

Refer to Figure 1-3 for the following steps.

- ( ) Install the 11-pin socket cap over the free end of the 8-conductor cable from the HP-13A power supply.
- ( ) Remove 7/8" of the outer insulation from the end of the 8-conductor cable. Then remove 1/4" of insulation from the ends of the exposed wires.
- ( ) Melt a small amount of solder on the exposed wire ends.
- ( ) Cut seven 5/8" lengths of large sleeving and slip them over the indicated wires.
- ( ) Connect the wires of the 8-conductor cable to the 11-pin socket as shown. Also, slip the in-line fuse wire through the 11-pin socket cap and connect it to lug 10. Solder each connection.
- ( ) Push the lengths of sleeving over the lugs of the socket.
- ( ) Snap the socket cap onto the 11-pin socket.

**IMPORTANT:** When using the HP-13A Power Supply with the Transceiver, be sure the Bias control of the Power Supply is in its fully clockwise position. This would supply a maximum bias voltage at pin 9 of the power socket. Also, read the warning under Mobile Operation on Page 109.

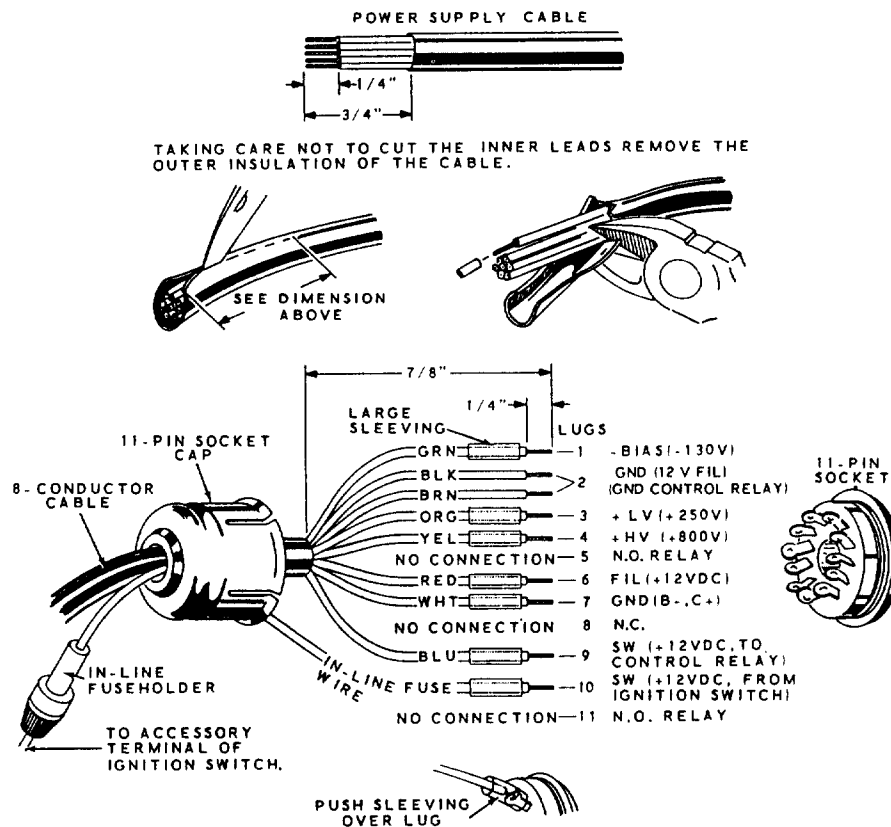

Figure 1-3

## HEATHKIT HP-23A POWER SUPPLY CONNECTIONS

CAUTION: Be sure the alternate connection in the low voltage DC circuit of the HP-23A Power Supply is connected for the +250 volt output as outlined in the HP-23A Power Supply Manual.

Refer to Figure 1-4 for the following steps.

- ( ) Install the 11-pin socket cap over the free end of the 8-conductor cable from the Power Supply.
- ( ) Remove 7/8" of the outer insulation from the end of the 8-conductor cable. Then remove 1/4" of insulation from the ends of the exposed wires.
- ( ) Melt a small amount of solder on the exposed wire ends.
- ( ) Cut seven 5/8" lengths of large sleeving and slip them over the indicated wires.
- ( ) Connect the wires of the 8-conductor cable to the 11-pin socket as shown. Solder each connection.
- ( ) Push the lengths of sleeving over the lugs of the socket.
- ( ) Snap the socket cap onto the 11-pin socket.

NOTE: With the above connections, the BIAS control in the HP-23A Power Supply is inoperative. Proper bias settings are accomplished with the BIAS control in the Transceiver.

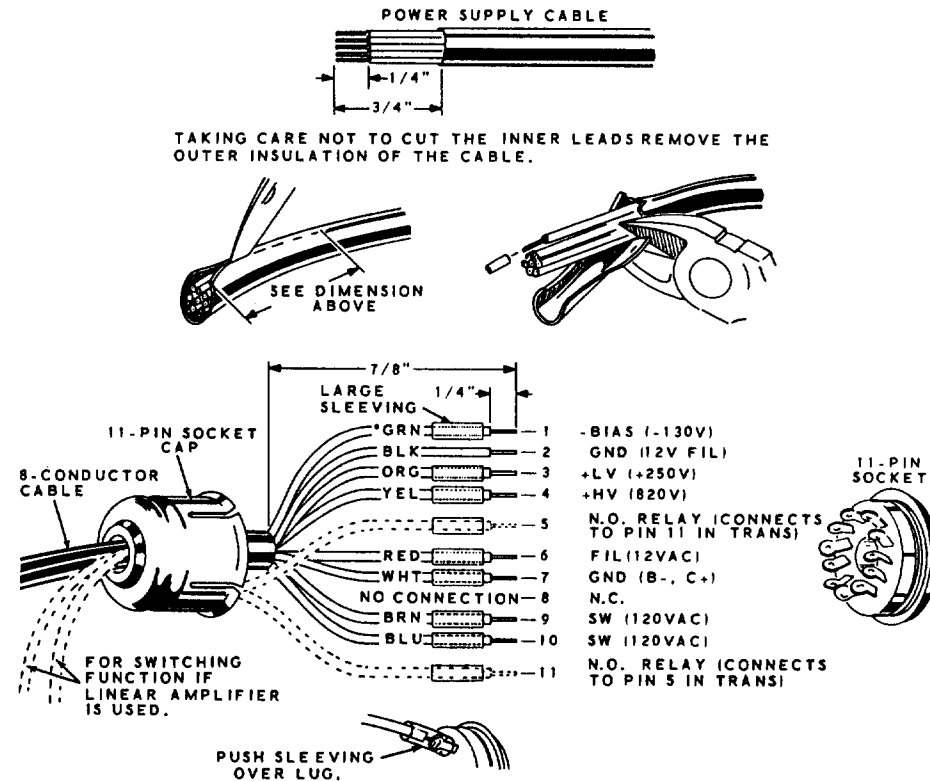

Figure 1-4

## INITIAL TEST

CAUTION: BEFORE APPLYING POWER TO THE TRANSCEIVER, NOTE THAT LETHAL VOLTAGES ARE PRESENT BOTH ABOVE AND BELOW THE CHASSIS. DO NOT TOUCH ANY HIGH VOLTAGE POINTS WITH YOUR HANDS. USE WELL INSULATED TOOLS FOR ANY ADJUSTMENTS ON THE CHASSIS.

TO LESSEN THE SHOCK HAZARD, CONNECT A LEAD FROM A GOOD EARTH GROUND TO THE GROUND BOLT LOCATED ON THE REAR OF THE CHASSIS AND TO ALL TEST EQUIPMENT.

( ) Be sure all controls are set as outlined on Page 81. Do not turn up the AF GAIN control in the following test, as oscillation may occur in the IF and audio sections when no tube shields are used.

( ) Check to see that the free leads of the 6800  $\Omega$  and 100  $\Omega$  1 watt resistors in section A are clear of the chassis and any connections.

If abnormal operation is encountered at any time during the following tests, turn the Transceiver off immediately, and refer to the In Case Of Difficulty section of the Manual (Page 110). Some symptoms of abnormal operation are: VR tube V16 does not glow violet or orange in color; either relay is activated; or any overheating.

( ) Connect the power supply to the Transceiver.

( ) Connect an 8  $\Omega$  speaker to the Transceiver. CAUTION: Never operate the Transceiver unless an 8  $\Omega$  speaker or headphones are connected.

( ) Turn the FUNCTION switch to PTT. The pilot lamps should light immediately, and in a few seconds the tubes should start to glow.

Check the following two voltages with a VTVM. See Figure 1-6 (fold-out from Page 82).

( ) Between chassis ground and feedthrough capacitor AT: -125 VDC.

( ) Between chassis ground and feedthrough capacitor AU: +250 VDC.

( ) Turn the FUNCTION switch to OFF.

Install the tube shields as follows:

( ) 1-3/4" long #206-77 tube shield at V12.

( ) 2" long #206-206 tube shield at V6.

( ) 1-15/16" long #206-3 tube shield at V7.

( ) 2-3/8" long #206-54 tube shield at V13.

( ) Seven 1-3/4" long #206-68 tube shields at the remaining locations on the circuit boards. Tube V16 has no shield.

( ) Install the final top plate on the final amplifier enclosure shield. Use #6 x 1/4" sheet metal screws.

( ) Remove the protective backing from the HIGH VOLTAGE label, then press the label firmly in place on top of the final top plate. Trim the label if necessary so it does not cover any of the holes.

# ALIGNMENT

Most of the coils and transformers in your Transceiver have been pre-set at the factory. If all wiring and components have been assembled according to the instructions and Pictorials, only slight readjustments will be necessary.

The following equipment is necessary for alignment.

1. An 11 megohm input VTVM.
2. A 50  $\Omega$  nonreactive dummy load capable of 100 watts dissipation, such as the Heathkit Model HN-31. Do not use light-bulbs as a dummy load.
3. A receiver capable of receiving WWV at 2.5, 5, 10, or 15 mc. If this type of receiver is not available, a receiver tunable to a standard broadcast station, operating at a multiple of 100 kc (such as 600 kc, 1000 kc, etc.), can be used.

## RECEIVER ALIGNMENT

Since it is necessary to get at both the top and bottom of the chassis, the alignment is much easier to perform if the chassis is positioned on its right side, with the front panel facing you.

Refer to Figures 1-5 and 1-6 (fold-out from Page 82) for the following coil, transformer, and control locations.

- ( ) Referring to the inset drawing in Figure 1-5, make up a 47  $\Omega$  load using a 47  $\Omega$  1/2 watt (yel-viol-blk) resistor (supplied with kit) and a phono plug.
- ( ) Plug the 47  $\Omega$  load into the ANT RF OUT jack on the rear of the chassis.

**WARNING:** Do not place the Transceiver in the transmit mode of operation until directed to do so or the Transceiver may be seriously damaged.

- ( ) Be sure an 8  $\Omega$  speaker is connected to the 8  $\Omega$  SPEAKER jack on the rear of the chassis.
- ( ) Refer to the inset drawing on Figure 1-5 and place a piece of tape on the long end of the alignment tool, as shown. This will give an accurate indication as to how far the alignment tool is being turned in the following adjustments.

## Section G Chassis Adjustments

**NOTE:** In a number of the following steps you will be directed to measure -DC voltages with your VTVM. These readings will be read as -DC voltages because of the way the test leads of the VTVM are connected to the Transceiver. Therefore, it is not necessary to use the -DC function, if your VTVM has this feature.

- ( ) Connect the negative lead of the VTVM to the TP (the free lead of the 100 K $\Omega$  resistor in Section H) and connect the other lead of the VTVM to the chassis. Set the range switch of the VTVM to a position where the VTVM can indicate a reading between -1.5 and -3 volts DC.
- ( ) Turn the FUNCTION switch to PTT, and allow the Transceiver to warm up for 1 or 2 minutes.
- ( ) With the BAND switch at 50.0, adjust coil L6 (50.0) for a maximum VTVM indication. Then turn the coil slug 1/4 turn counterclockwise.
- ( ) Adjust coil L10 (50.0) for a maximum VTVM indication. An approximate VTVM reading of -2 volts should be obtained.
- ( ) Set the BAND switch at 50.5 and adjust coil L7 (50.5) for a maximum VTVM indication. Turn the coil slug 1/4 turn counterclockwise.
- ( ) Adjust coil L11 (50.5) for a maximum VTVM indication.
- ( ) Set the BAND switch at 51.0 and adjust coil L8 (51.0) for a maximum VTVM indication. Turn the coil slug 1/4 turn counterclockwise.
- ( ) Adjust coil L12 (51.0) for a maximum VTVM indication.
- ( ) Set the BAND switch at 51.5 and adjust coil L9 (51.5) for a maximum VTVM indication. Turn the coil slug 1/4 turn counterclockwise.
- ( ) Adjust coil L13 (51.5) for a maximum VTVM indication.

When adjusting coils L10, L11, L12, and L13, the -2 volt VTVM reading will vary slightly with different settings of the PRESELECTOR. This is a normal condition. Any unusually high or low voltage readings should be investigated. See the In Case Of Difficulty section of the Manual.

- ( ) Return the BAND switch to the 50.0 position.
- ( ) Disconnect the VTVM leads from the Transceiver. Set the VTVM to its lowest AC voltage range.
- ( ) Connect the AC leads of the VTVM to the voice coil lugs of the speaker or the lugs of the phono socket.
- ( ) Advance the AF GAIN control until some background noise is heard from the speaker.

NOTE: There are two slug settings of transformers T2 and T3 which will give maximum VTVM indications. Use the setting that places the slug nearest the circuit board.

- ( ) Adjust transformer T3 (Section G) for maximum noise or VTVM indication.
- ( ) Adjust transformer T2 (Section G) for a maximum VTVM indication.
- ( ) Turn the FUNCTION switch to OFF.
- ( ) Temporarily connect a jumper wire between 4 and 5 (between org and grn coaxial cables) on the foil side of Receiver RF Circuit Board #85-114-1 (Section F).

#### Section H Chassis Adjustments

- ( ) Turn the FUNCTION switch to CAL.
- ( ) Set the Transceiver to 50.10 mc. (BAND switch to 50.0, the upper dial to 1, and the circular dial to 0).
- ( ) Now, rock the Main Tuning dial back and forth approximately 20 kc on each side of the 50.10 mc setting (between 20 and 80 on the circular dial). Observe that there are two signals approximately 10 kc apart. Set the Main Tuning half-way between these two signals.
- ( ) Adjust the CAL ADJ trimmer capacitor (Section M) until a signal is heard at the above Main Tuning dial setting. This signal may be weaker than the above two signals, depending on the factory preset adjustment of L2.
- ( ) With the PRESELECTOR set at the 10 o'clock position, adjust coil L4 for a maximum VTVM indication.

- ( ) Adjust coil L3 for a maximum VTVM indication.
- ( ) Adjust coil L1 for a maximum VTVM indication.
- ( ) Adjust coil L2 for a minimum signal leak-through (a null VTVM indication).
- ( ) Readjust coils L4, L3, and L1 for a maximum VTVM indication.
- ( ) Turn the FUNCTION switch to OFF.
- ( ) Place a piece of tape over the alignment hole of L2 to prevent adjustment of this coil by accident.
- ( ) Remove the temporary jumper wire from between 4 and 5 on the foil side of the Receiver RF circuit board (Section F).
- ( ) Install a 33 K $\Omega$  (org-org-org) 2 watt resistor on the Receiver RF circuit board (Section H). Solder and cut off the excess leads.
- ( ) Turn the FUNCTION switch to the CAL position. CAUTION: Do not attempt to readjust coil L2 in the following step. L2 is the neutralizing coil and can be adjusted only when the B+ voltage is removed from the RF stage.
- ( ) Carefully retouch the adjustments of transformers T3 and T2 (Section G) and coils L4, L3, and L1 (Section H) for maximum VTVM indication.
- ( ) Disconnect the VTVM leads from the speaker.

#### S-Meter Adjustment

- ( ) Turn the FUNCTION switch to PTT.
- ( ) Set the METER switch to the PLATE position, and adjust the S-METER "0" ADJ control (Section M) for a zero reading on the panel meter.
- ( ) Set the METER switch to the ALC position, and adjust the ALC METER ADJ control (Section G) for a zero reading on the panel meter.
- ( ) Repeat the previous two steps until no meter deflection occurs at the PLATE and ALC settings of the METER switch.
- ( ) Turn the FUNCTION switch to OFF.



## TRANSMITTER ALIGNMENT

- ( ) Temporarily solder the free lead of the 6800  $\Omega$  1 watt resistor from AL8 to AU (Section A). Do not make a permanent connection at this time. Be sure the 100  $\Omega$  1 watt resistor is clear of the chassis and all connections.
- ( ) Connect the negative test lead of the VTVM to AL2 (Section A), and connect the other lead to the chassis.
- ( ) Set the VTVM to read at least -150 volts DC.
- ( ) Set the FUNCTION switch to PTT. The VTVM should indicate approximately -125 volts.
- ( ) Turn the MODE switch to the TUNE position. Both relays should energize, and the VTVM reading should drop to approximately zero volts. Adjust the range switch of the VTVM to obtain a reading near center scale.
- ( ) Set the DRIVER control at the 10 o'clock position.
- ( ) Advance the MIC/CW LEVEL control fully clockwise.
- ( ) Adjust coil L14 (Section M) for a maximum VTVM indication.
- ( ) Adjust coil L15 (Section M) for a maximum VTVM indication.
- ( ) Adjust coil L16 (Section L) for a maximum VTVM indication.
- ( ) Repeat the above three steps until there is no further increase in the indication on the VTVM.

NOTE: The transformer that is adjusted in the next step is preset and should require no more than 1/2 turn for a peak adjustment.

- ( ) Adjust transformer T5 (Section J) for a maximum VTVM indication.
- ( ) Return the range switch of the VTVM to a position where the VTVM can indicate at least -150 volts.
- ( ) Turn the FUNCTION switch to OFF.
- ( ) Remove the negative lead from AL2 and connect it to AT (Section A).
- ( ) Set the MODE switch at LSB.
- ( ) Turn the FUNCTION switch to PTT. The VTVM should indicate approximately -125 volts.

- ( ) Set the MODE switch to the TUNE position. The VTVM reading should drop to approximately -45 volts. (Be sure the BIAS ADJ control is in its fully counterclockwise position.)
- ( ) With the MIC/CW LEVEL control in the fully clockwise position, adjust coil L16 (Section L) for a maximum VTVM indication.
- ( ) Adjust coil L15 (Section M) for a maximum VTVM indication.
- ( ) Adjust coil L14 (Section M) for a maximum VTVM indication. The peak indication should be approximately -60 to -70 volts.

IMPORTANT: Upon changing the OSC. MODE switch to the AUX T position, the VTVM indication should drop to approximately -45 volts. If the VTVM indication does not drop to the bias level (-45 V) coils L14, L15, and L16 have been adjusted to the heterodyne oscillator output signal. If this has occurred, turn each of the three coil slugs counterclockwise at least five full turns. Return the OSC MODE switch to the LMO position, and repeat all the previous steps beginning with the sixth step in the left-hand column on this page.

- ( ) Remove the 47  $\Omega$  load from the ANT RF OUT jack on the rear of the chassis.
- ( ) Refer to the inset drawing on Figure 1-6 and make up a trimmer alignment tool with the alignment tool blade and the nut starter. This tool is to be used for the adjustment of the FINAL NEUT and the DRIVER NEUT trimmers.
- ( ) Set the METER switch to the REL PWR position.
- ( ) Turn the FINAL load control fully clockwise.
- ( ) Be sure the REL PWR ADJ control (Section M) is in its fully clockwise position.
- ( ) Adjust the FINAL tune control for a maximum panel meter indication. This should be approximately half-scale.
- ( ) While carefully observing the panel meter, adjust the FINAL NEUT trimmer capacitor (Section A) for a minimum meter indication.
- ( ) Return the MIC/CW LEVEL control to its fully counterclockwise position.
- ( ) Adjust the BIAS ADJ control (Section K) for a -50 volt reading on the VTVM.

- ( ) Set the MODE switch to LSB.
  - ( ) Turn the FUNCTION switch to the OFF position.
  - ( ) Disconnect the VTVM leads from the Transceiver.
  - ( ) Disconnect the lead of the 6800  $\Omega$  1 watt resistor from AU (Section A).
  - ( ) Solder the free lead of the 100  $\Omega$  1 watt resistor from AF3 to AU (S-3) (Section A). This is a permanent connection.
  - ( ) Turn the FUNCTION switch to PTT.
  - ( ) Set the METER switch to PLATE.
  - ( ) Turn the MODE switch to TUNE. The panel meter should indicate 50 ma of static plate current; if it does not, readjust the BIAS ADJ control for 50 ma.
  - ( ) Set the METER switch to the REL PWR position.
  - ( ) Turn the MIC/CW LEVEL control fully clockwise.
  - ( ) Return the FINAL load control to its 50  $\Omega$  position.
  - ( ) Adjust the FINAL tune control for a maximum panel meter indication, about 1 or 2 S-units.
  - ( ) While carefully observing the panel meter, adjust the DRIVER NEUT trimmer capacitor (Section L) for a minimum meter indication.
  - ( ) Return the MIC/CW LEVEL control to its fully counterclockwise position.
  - ( ) Set the MODE switch to LSB.
  - ( ) Turn the FUNCTION switch to OFF.
  - ( ) Reconnect the 6800  $\Omega$  1 watt resistor to AU. This is a permanent connection. Be sure all leads and wires at AU are soldered.
  - ( ) Connect a 50  $\Omega$  dummy load, capable of 100 watts dissipation, to the RF OUT jack on the rear of the chassis. CAUTION: Do not use light bulbs as a dummy load.
  - ( ) Set the FUNCTION switch to PTT.
  - ( ) Be sure the MIC/CW LEVEL control is in its fully counterclockwise position.
  - ( ) Place the MODE switch in the TUNE position.
  - ( ) Adjust transformer T5 (Section J) for a minimum (null) panel meter indication. This should require no more than 1/2 turn of the coil slug. After this null is found, turn the slug clockwise until a second null indication occurs. Leave the slug set at this second null position.
  - ( ) Place the METER switch in the PLATE position. The panel meter should read 50 ma. If there is any difficulty in obtaining either a null or the above plate current reading, interchange tube V9 with V4. If a tube change is required, it will be necessary to recheck the IF alignment (transformers T2 and T3) and the S-METER "0" ADJ control settings.
  - ( ) Turn the REL PWR METER ADJ control (Section M) to the center of its range.
  - ( ) Turn the MIC/CW LEVEL control to the 11 o'clock position. The plate current should increase slightly.
  - ( ) Adjust the DRIVER control for a maximum plate current. If necessary, keep the plate current to less than 250 ma by decreasing the MIC/CW LEVEL control setting.
  - ( ) Adjust the FINAL tune control for a plate current dip (null).
  - ( ) Slowly advance the MIC/CW LEVEL control, while repeating the previous two steps, until the panel meter indicates 250 ma.
- NOTE: If the dummy load being used is 50  $\Omega$  and non-reactive, it should not be necessary to move the FINAL loading control from its preset position. However, if the dummy load is other than 50  $\Omega$  and/or reactive, the FINAL loading control must be adjusted for maximum output as follows:
- ( ) Set the METER switch at the REL PWR position.
  - ( ) Adjust the REL PWR METER ADJ (Section M) for a half scale panel meter indication.

- ( ) Adjust both the FINAL tuning and FINAL loading controls for a maximum panel meter indication. CAUTION: Be sure the plate current does not exceed 250 ma when adjusting these controls.
- ( ) Return the MIC/CW LEVEL control to its fully counterclockwise position.
- ( ) Place the MODE switch in the USB position.
- ( ) Turn the REL PWR METER ADJ control fully clockwise.

### CARRIER NULL ADJUSTMENTS

NOTE: If the CARRIER BAL ADJ capacitor is at minimum capacity (plates fully unmeshed) after the Carrier Null adjustments are completed, move the capacitor from position A to position B on the Carrier Generator circuit board. Also, if the CARRIER NULL ADJ control is at either extreme of rotation, interchange resistors R220 and R222 (see X-Ray View at the end of the manual) on the Carrier Generator circuit board. Then, repeat the following adjustments.

- ( ) Connect one end of a wire to lug 2 of MIC connector NF. Connect the other end of this wire to the chassis. This will energize the relays.
- ( ) Set the METER switch to the REL PWR position. This should result in a panel meter reading of 1 or 2 S-units.
- ( ) Adjust the CARRIER NULL ADJ control (Section J) for a null indication on the panel meter.
- ( ) Adjust the CARRIER BAL ADJ trimmer capacitor for a null indication on the panel meter.
- ( ) Repeat the previous two steps until no further improvement can be made in the null indication. The panel meter should now be at the "0" indication.

NOTE: Better carrier suppression can be achieved by placing an external receiver, tuned to either 50.1 or 8.5 mc, near the Transceiver. Temporarily place the MODE switch of the Transceiver in the TUNE position, and use the BFO of the external receiver to tune the external receiver for a beat note. Return the MODE switch of the Transceiver to the USB position, and adjust both the CARRIER NULL ADJ control

and CARRIER BAL ADJ capacitor (Section J) for minimum signal in the external receiver.

It may be necessary to connect a length of wire to the antenna terminal of the external receiver, and position it close to the Transceiver, in order to hear the signal when the suppression of the carrier gets lower.

- ( ) Turn the MODE switch to LSB. If the carrier signal increases slightly, adjust the CARRIER NULL ADJ control for a compromise between the LSB and USB positions. This can be done easily if the external receiver has an S-meter. This way, the relative readings between the two sideband positions of the MODE switch can be observed. However, with careful adjustment for a minimum carrier on one sideband, the other sideband will have carrier suppression equal to, or better than specified.

NOTE: When the carrier suppression adjustments are completed, recheck the static plate current. Readjust the BIAS control for plate current indication of 50 ma, if necessary.

- ( ) Remove the wire connected between lug 2 of MIC connector NF and the chassis.

### CRYSTAL CALIBRATOR ALIGNMENT

In the following steps, the 100 kc crystal calibrator signal is adjusted by "zero beating" it against the accurate signal from WWV on another receiver (or against the signal from a standard broadcast station that is a multiple of 100 kc). Zero beat will occur when a harmonic of the 100 kc crystal calibrator signal corresponds to the frequency of the station tuned in on the external receiver. As zero beat is approached, a tone will be heard that decreases in frequency until it stops completely; then the tone begins to increase again.

If the external receiver has an S-meter, quite accurate alignment can be achieved by observing the S-meter as zero beat is approached. When you tune close to zero beat, the S-meter will start to pulsate. The closer you approach zero beat, the slower the pulsation will become, and at zero beat the pulsation will stop.

**IMPORTANT:** For greatest accuracy, be sure to adjust the crystal calibrator as close to zero beat as possible. A 20 cps error at the 100 kc calibrator frequency for example, will cause a 10 kc error at the 6-meter frequency of 50 mc (the 500th harmonic of 100 kc is used for dial calibration purposes;  $100 \text{ kc} \times 500 = 50 \text{ mc}$ ;  $20 \text{ cps} \times 500 = 10 \text{ kc}$ ).

- ( ) Wrap the free end of the antenna wire from the external receiver, one or two turns around the insulation of the inner lead of the org shielded cable at 5 on the Receiver RF Circuit board (Section F).
- ( ) Turn the Transceiver AF GAIN control fully counterclockwise.
- ( ) Set the Transceiver FUNCTION switch to CAL.
- ( ) Tune the external receiver to WWV; or a standard broadcast station broadcasting at a frequency which is a multiple of 100 kc.
- ( ) Adjust the CAL ADJ trimmer capacitor (Section M) for a "zero beat" in the external receiver. When WWV is tuned in, the period when no tone modulation is present allows easier identification of zero beat.
- ( ) Switch the Transceiver FUNCTION switch between VOX and CAL to make sure the S-meter stays steady, thus insuring a true zero beat.
- ( ) Remove the external receiver antenna wire from the Transceiver.

**NOTE:** To make sure it is heard on the 6-meter band, a high content of harmonic energy is needed in the 100 kc calibrate signal. Because of this, some spurious signals may also appear when tuning across each 100 kc segment of the band. The desired 100 kc calibrate signals are easily identified by their larger signal strength. Also, by turning the BAND switch to the next position and back to its original position, a chirp (due to the starting of the heterodyne oscillator crystal) will be heard at the desired 100 kc calibrate signal.

#### LMO SHIFTER ADJUSTMENT

- ( ) Adjust the Main Tuning dial to 50.10 mc (BAND switch to 50.0, the upper dial to 1, and the circular dial to 0).

- ( ) Set the FUNCTION switch at CAL.
- ( ) Turn the MODE switch to LSB.
- ( ) Carefully zero beat the calibrator signal (using the Main Tuning dial) and peak the PRESELECTOR.
- ( ) Set the MODE switch to USB. Be careful not to touch the Main Tuning dial. Note that the calibrator signal may or may not be exactly at zero beat in the USB position.
- ( ) Turn the frequency shifter adjustment on the LMO for an exact zero beat in the USB mode.
- ( ) Recheck the zero beat in the LSB mode to be certain of the adjustment. Repeat the procedure if necessary.

#### DIAL CALIBRATION

- ( ) Zero beat the Main Tuning dial at 50.10 mc.
- ( ) Set the zero set dial line in the center of the circular dial window.
- ( ) Remove the knob from the Main Tuning shaft without disturbing the zero beat setting.
- ( ) Place a screwdriver through the hole, the dial escutcheon (directly above the main tuning shaft) and into the LMO dial drive shaft.
- ( ) Hold the LMO dial drive shaft on zero beat and loosen the setscrew in the circular dial. Turn the circular dial until the 0 is directly under the line on the zero set dial. Now retighten the setscrew in the circular dial.
- ( ) Make sure the circular dial turns freely and the nylon spiral follower is properly engaged in the spiral before proceeding.
- ( ) Replace the knob on the Main Tuning shaft.

This completes the alignment of your Transceiver.

## SPECIAL CRYSTAL CONSIDERATIONS

The heterodyne crystals supplied with the Transceiver provide continuous band coverage from 50 to 52 megacycles. Other 500 kc band segments can be used if other crystals are installed in place of those supplied. The following chart lists the remaining band segments and the crystal frequencies that must be used for these band segments.

If one or more heterodyne oscillator crystals are changed, readjust the associated heterodyne oscillator and oscillator amplifier coils as described in the Alignment section of the Manual.

BAND SEGMENT	HET OSC CRYSTAL FREQ.
*49.5 to 50.0 MC	41.105 MC
52.0 to 52.5 MC	43.605 MC
52.5 to 53.0 MC	44.105 MC
53.0 to 53.5 MC	44.605 MC
53.5 to 54.0 MC	45.105 MC

\*This crystal is listed to make it possible to use the Transceiver on the MARS frequencies extending 500 kc below 50.0 megacycles. NOTE: The power output and receiver sensitivity will decrease progressively as frequencies approaching 49.5 megacycles are used. See also the following information on Crystal Control For MARS Or Net Operation.

When purchasing crystals for use in the heterodyne oscillator section of the Transceiver, be sure to specify the following crystal characteristics. Crystals that do not meet these requirements will not provide optimum performance.

Operation Mode - 3rd overtone.

Tolerance -  $\pm 0.003\%$ .

Holder - HC-6/U.

Pin Diameter - .050".

Pin Spacing - .486".

Load Capacity ( $C_L$ ) - 23.2  $\mu\mu f$ .

Internal Capacity ( $C_O$ ) - 5  $\mu\mu f$  maximum.

Series Resistance ( $R_s$ ) - 30  $\Omega$  maximum.

Drive Level - 10 milliwatts.

### CRYSTAL CONTROL FOR MARS OR NET OPERATION

With the Mode switch of the Transceiver in the AUX T position, the transmitter operates at a fixed frequency that is determined by crystal Y6 in crystal oscillator circuit V3B. The receiver is still tuned by the LMO.

By placing the Mode switch in the XTAL position, both the transmitter and receiver frequencies are determined by crystal Y6.

**IMPORTANT:** Because of the steep-sided characteristics of Bandpass Couplers T1 and T6, out-of-band (below 50.0 mc) operation of the Transceiver using a crystal at Y6, will be limited to approximately 25 kilocycles. If crystal control is desired beyond this limit, it will be necessary to change to the 41.105 mc heterodyne crystal.

Select the crystal frequency for Y6 for the sideband to be used. The examples below are for one of the MARS channels located at 49,980 megacycles.

For USB operation,

$$f_{O(USB)} = (f_M - f_N) - 3.3936$$

$f_M$  = MARS Frequency. . . . . 49,9800 mc.

$f_N$  = Heterodyne Oscillator Crystal. . . -41,6050 mc.

1st IF Frequency. . . . . =8,3750 mc.

USB Carrier Generator Crystal. . . -3,3936 mc.

$f_{O(USB)}$  = Crystal for Y6 (USB). . . . . =4,9814 mc.

For LSB operation,

$$f_{O(LSB)} = (f_M - f_N) - 3.3964$$

$f_M$  = MARS Frequency. . . . . 49,9800 mc.

$f_N$  = Heterodyne Oscillator Crystal. . . -41,6050 mc.

1st IF Frequency. . . . . =8,3750 mc.

LSB Carrier Generator Crystal. . . -3,3964 mc.

$f_{O(LSB)}$  = Crystal for Y6 (LSB). . . . . =4,9786 mc.

When purchasing crystals for Y6, specify the frequency and the following characteristics.

Operation Mode. . . . . Fundamental.

Tolerance. . . . . .01%.

Holder. . . . . HC-6/U.

Pin Diameter. . . . . .050".

Pin Spacing. . . . . .486.

Load Capacity ( $C_L$ ). . . . . 15  $\mu$ f.

Internal Capacity ( $C_O$ ). . . . . 7  $\mu$ f maximum.

Series Resistance ( $R_s$ ). . . . . 25  $\Omega$  maximum.

Drive Level. . . . . 2 milliwatts.

The trimmer capacitor next to Y6 (XTAL ADJ) can be adjusted for an exact MARS or Net frequency.

## CABINET INSTALLATION

**NOTE:** If the Transceiver is to be mounted with the Heathkit Mobile Mount, Model SBA-100-1: be sure to install the plastic snap-in nuts in the side-front corners of the chassis, and install the threaded bushing in the rear apron of the chassis. These parts are supplied with the Mobile Mount.

Refer to Pictorial 3-47 for the following steps.

- ( ) Position the cabinet right-side up on the work area.
- ( ) Slide the chassis into the cabinet from the front.
- ( ) Carefully turn the cabinet and chassis over.
- ( ) Install a rubber foot at each rear corner using 6-32 x 5/8" screws and #6 flat washers. The screws fit through the cabinet holes into the threaded holes in the chassis.
- ( ) Install a rubber foot and a foot spacer at each front corner of the cabinet, using a 6-32 x 1-1/2" screw and a #6 flat washer.
- ( ) Start 8-32 x 1/4" oval head screws into the front-side holes of the cabinet.
- ( ) Close the cover and tighten the screws.

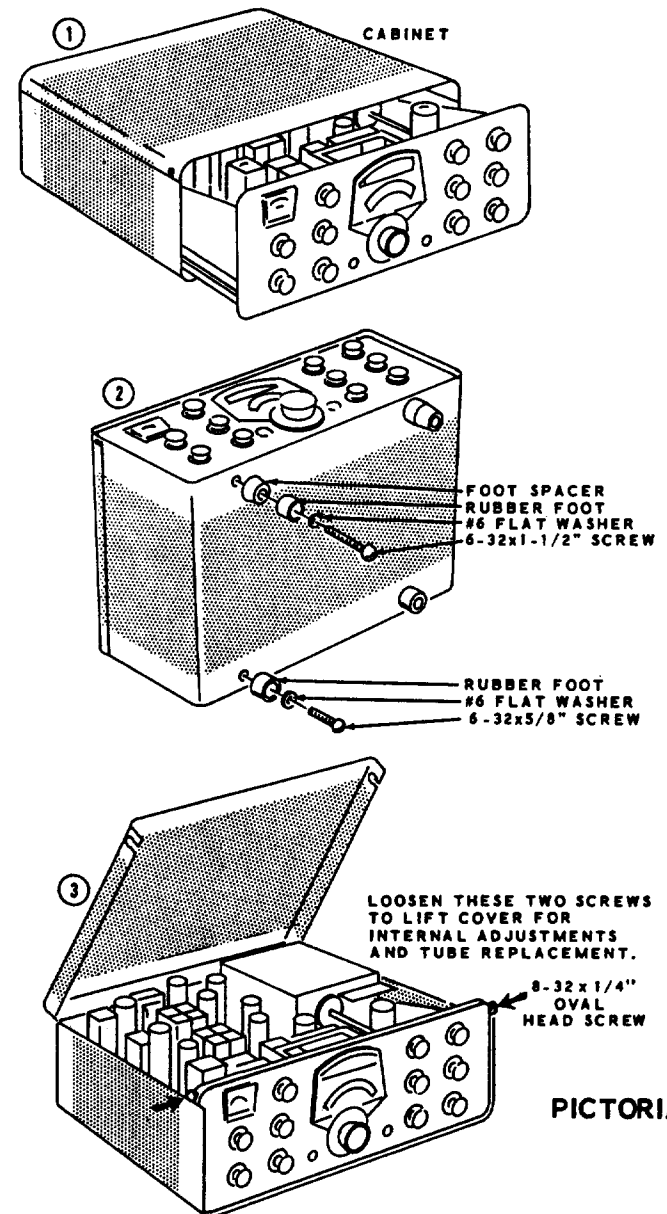

## MICROPHONE CONNECTION

Refer to Figure 1-7 for the following step.

**NOTE:** It is recommended that a high impedance microphone equipped with a push-to-talk switch be used with this Transceiver, so that advantage may be taken of the PTT operation in addition to VOX. A 2-pin male microphone connector (Amphenol 80MC2M) is furnished for this purpose.

- ( ) Determine the desired length of your microphone cord and cut off any excess. Unbraid the shield for a distance of  $7/8$ ". Remove the two conductors to a length of  $1/2$ " and melt a small amount of solder on the exposed wire ends. Then proceed to the steps on Figure 1-7.

## IDENTIFICATION LABEL

**NOTE:** The blue and white identification label shows the Model Number and Production Series Number of your kit. Refer to these numbers in any communications with the Heath Company; this assures you that you will receive the most complete and up-to-date information in return.

- ( ) Install the identification label in the following manner:

1. Select a location for the label where it can easily be seen when needed, but will not show when the unit is in operation. This location might be on the rear panel or the top of the chassis, or on the rear or bottom of the cabinet.
2. Carefully peel away the backing paper. Then press the label into position.

- ① DETERMINE WHICH LEAD IS THE AUDIO LEAD

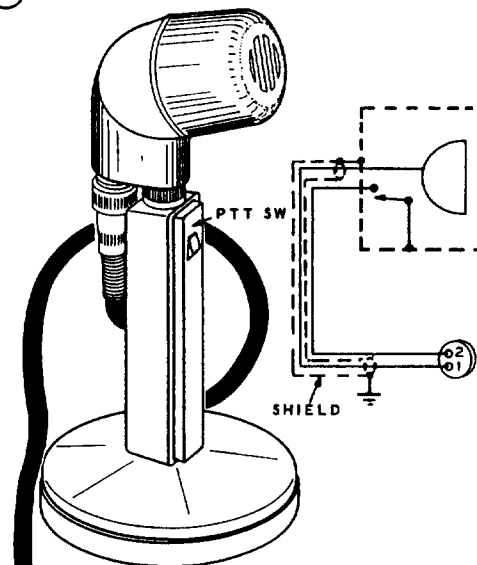

- ② PREPARE THE END OF THE MICROPHONE CABLE AS SHOWN.

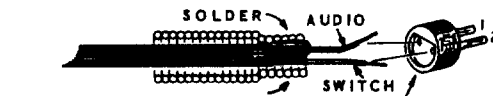
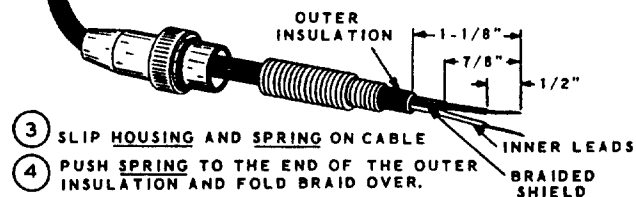

NOTE NUMBERS INSIDE OF CONNECTOR BASE

- ⑤ PUSH THE AUDIO LEAD THROUGH PIN 1 AND THE PTT LEAD THROUGH PIN 2
- ⑥ SOLDER BOTH PINS FROM THE BOTTOM THEN CUT OFF THE EXCESS WIRE

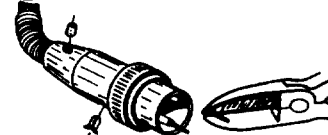

- ⑦ SLIP THE HOUSING OVER THE ASSEMBLY AND FASTEN BOTH SETSCREWS

Figure 1-7



## INSTALLATION

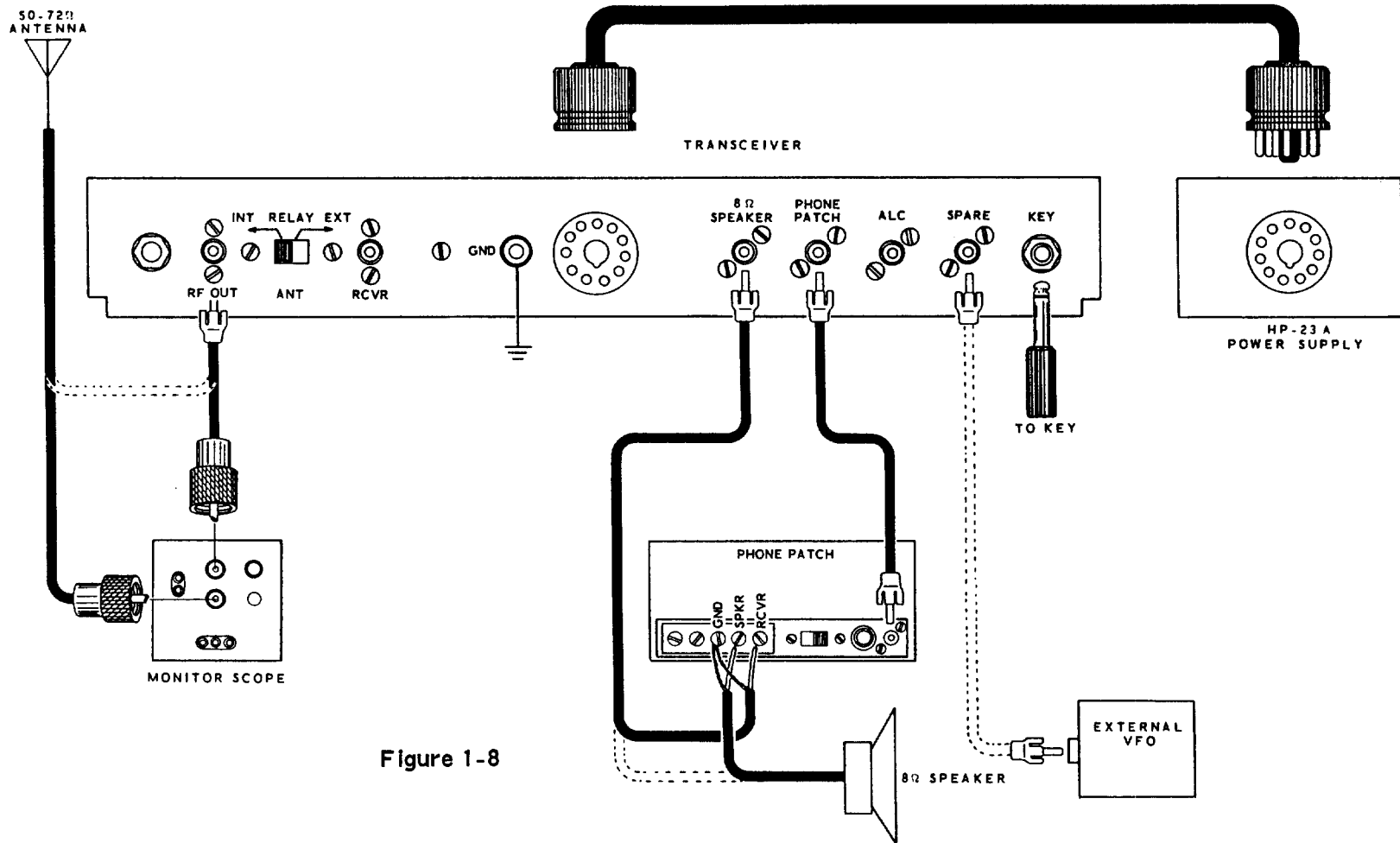

Figure 1-8

Because of the heat generated by the tubes of the Transceiver, it should be placed where adequate air circulation is present. Do not place other equipment, papers, or other objects under or on top of the Transceiver, since this would cut off air circulation through the chassis.

### FIXED STATION INSTALLATION

Figure 1-8 shows a typical fixed station hookup. Various accessories are shown that may be used with the Transceiver. These same accessories may be used when using a linear amplifier; however, the linear

amplifier hookup is shown separately in Figure 1-10 for clarity.

When using the Transceiver as a complete station unit, the ANT RELAY switch should be at the INTERNAL position, as shown in Figure 1-8.

CUT THE CABLE ACCORDING TO THE DIMENSIONS BELOW. PREPARE EACH END AS SHOWN.



INSERT THE INNER LEAD OF ONE END OF THE CABLE THROUGH THE PLUG AND WRAP THE SHIELD AROUND THE PLUG.



APPLY HEAT TO THE TIP OF THE PIN ONLY LONG ENOUGH FOR THE SOLDER TO BE DRAWN UP INTO THE PIN BY CAPILLARY ACTION. CUT OFF EXCESS WIRE FROM THE TIP OF THE PIN. SOLDER THE SHIELD TO THE PLUG.

Figure 1-9

Cables can be prepared following the instructions in Figure 1-9. Make the cables to the lengths required for your installation.

### Linear Amplifier Considerations

Information regarding antenna switching, cutoff bias, and ALC should be obtained from the Linear Amplifier Instruction Manual. Figure 1-10 shows a typical installation using a linear amplifier. This linear amplifier provides ALC voltage and uses cutoff bias during receive or standby periods, but it does not have an internal antenna switching relay.

A spare set of normally-open relay contacts are available at the power plug of the Transceiver (lugs 5 and 11). These contacts can be used to switch an external antenna relay. Power for the external antenna relay will have to be obtained externally. Under these conditions, the ANT RELAY switch should be in the EXTERNAL position with the coaxial cables connected as shown.

The external antenna relay should have an extra set of relay contacts to remove the cutoff bias of the linear amplifier during transmit periods.

If the linear amplifier being used has internal antenna switching capabilities, the ANT RELAY switch on the Transceiver can be at the INTERNAL position. Under these conditions, the external antenna relay

is not necessary, and there will be no connection at the ANT RCVR jack on the Transceiver. The spare relay contacts in the Transceiver can now be used to switch either the cutoff bias or the internal antenna relay of the linear amplifier.

If ALC voltage is available from the linear amplifier, be sure a high output impedance is available at the ALC output jack. See Operation With a Linear Amplifier on Page 109.

If the output power of the Transceiver is too high for the drive requirements of the linear amplifier, a swamping T-pad must be used between the two units. Such a pad is shown below. This pad will provide 10 db of attenuation with a terminal impedance of 50 ohms. This will allow adequate driving power for a linear amplifier that requires 10 watts input.

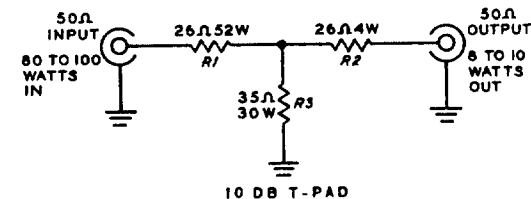

Resistors R1, R2, and R3 can be made from combinations of common 2 watt carbon resistors wired into a metal box with phono-type jacks for connectors. NOTE: Do not use wirewound resistors; the resistors in the T-pad must be a non-inductive type.

Combinations of 2 watt carbon resistors, for a pad suitable for SSB service at reduced power dissipation, are listed below. WARNING: Steady full level carrier excitation should be avoided except for very brief test periods, since the dissipation rating of the resistors will be exceeded.

R1 = thirteen 330  $\Omega$  2 watt carbon resistors in parallel.

R2 = two 47  $\Omega$  2 watt carbon resistors in parallel.

R3 = eight 270  $\Omega$  2 watt carbon resistors in parallel.

The preceding resistor combinations use the standard RETMA values that are closest to the exact (calculated) pad resistances. These resistance values are close enough to the calculated values for most applications.

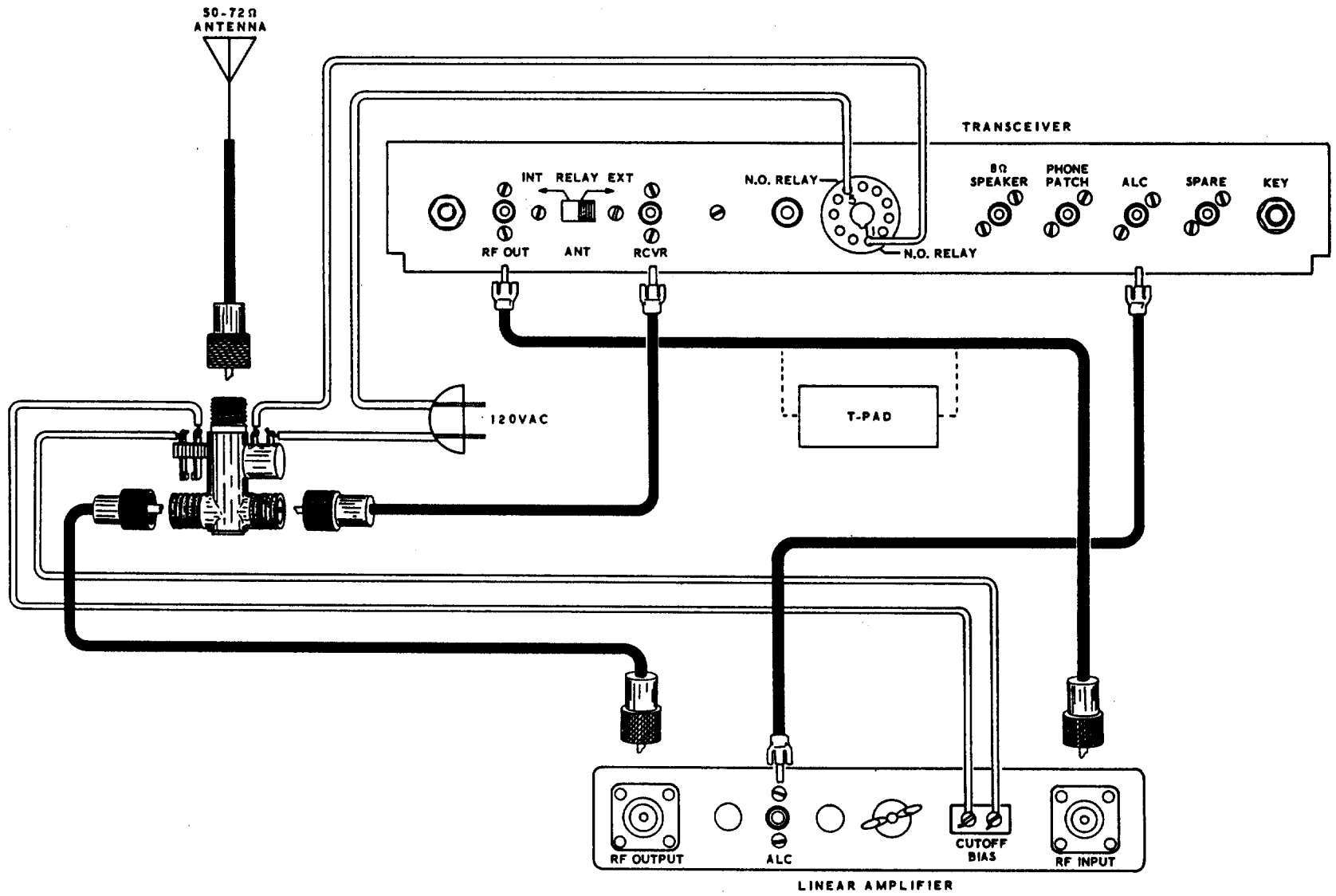

Figure 1-10

## MOBILE INSTALLATION

A mobile mount (Heathkit Model SBA-100-1) is available for use with the Transceiver, and is recommended for Mobile operation. With this mount, the Transceiver can be quickly and easily installed or removed, so it can be used for both mobile and fixed station operation.

Mobile antennas will not be discussed here because of the numerous types that are available. The only requirement is that the antenna be matched as close as possible to 50 ohms.

### Noise Suppression

The SB-110A Transceiver has an excellent noise-limiter circuit included in its design. This circuit will limit most electrical interference. However, the noise limiter should not be given too much work to do as at high engine speeds, a noisy ignition system, generator "whine," and voltage regulator "hash" will tend to mask weak signals, although with the limiter working, the interference may appear to be completely eliminated.

Another reason for good electrical interference suppression at the source, is that strong electrical pulses contain enough energy, when integrated, to block the AGC circuit of the receiver, causing the gain to drop whenever the engine is speeded up. In addition, the IF amplifiers of the receiver will tend to lengthen the duration of the noise pulses, because the relatively high-Q IF tuned circuits will ring, or oscillate, when excited by a sharp pulse such as produced by ignition noise.

Determining the source of various types of noise can be difficult, particularly when several items are contributing to the noise. Follow the procedure outlined below to isolate and identify the various items that may be producing the major noise interference.

In some cases, one source of interference will mask all others. Consequently, it will be necessary to suppress the questionable item and then continue with the other steps. Figure 1-11 shows a typical ignition system and the suggested placement of noise suppression components.

1. Locate the vehicle in an area that is free from other man-made electrical interference such as power lines, manufacturing processes, and particularly other automobiles.
2. With the Transceiver on and the NOISE LIMITER off, run the automobile at medium speed. Then let up on the gas, turn the ignition switch off and to the accessory position. Allow the vehicle to coast in gear. If all noise stops, the major source of interference is from the ignition system.
3. If the noise interference continues from step 2, but at a reduced level, both the ignition and generator systems are at fault.
4. If the noise has a "whine" characteristic and changes in pitch with varying engine speed and is still present with the ignition off, then the generator is the major source of interference.
5. A distinct but irregular clicking noise, or "hash" as it is sometimes called, that disappears with the ignition off, indicates the voltage regulator is at fault.
6. A steady popping noise that continues with the ignition off indicates wheel or tire static interference. This is more pronounced on smooth roads.
7. The same type of interference as in step 6, but more irregular when on bumpy roads, particularly at slow speeds, indicates body static.

Refer to the Noise Suppression Troubleshooting Chart on Page 104 and to Figure 1-11 on Page 103 to help determine how to suppress most noise interference. Naturally, not all vehicles will require suppression to the extent shown in Figure 1-11, but some stubborn cases may require all the suppression components as shown, plus shielding of the ignition system.

Bonding of various parts of the automobile, starting from the hood and continuing to the trunk, even including bonding of the transmission line every few feet from the antenna cannot be overemphasized.

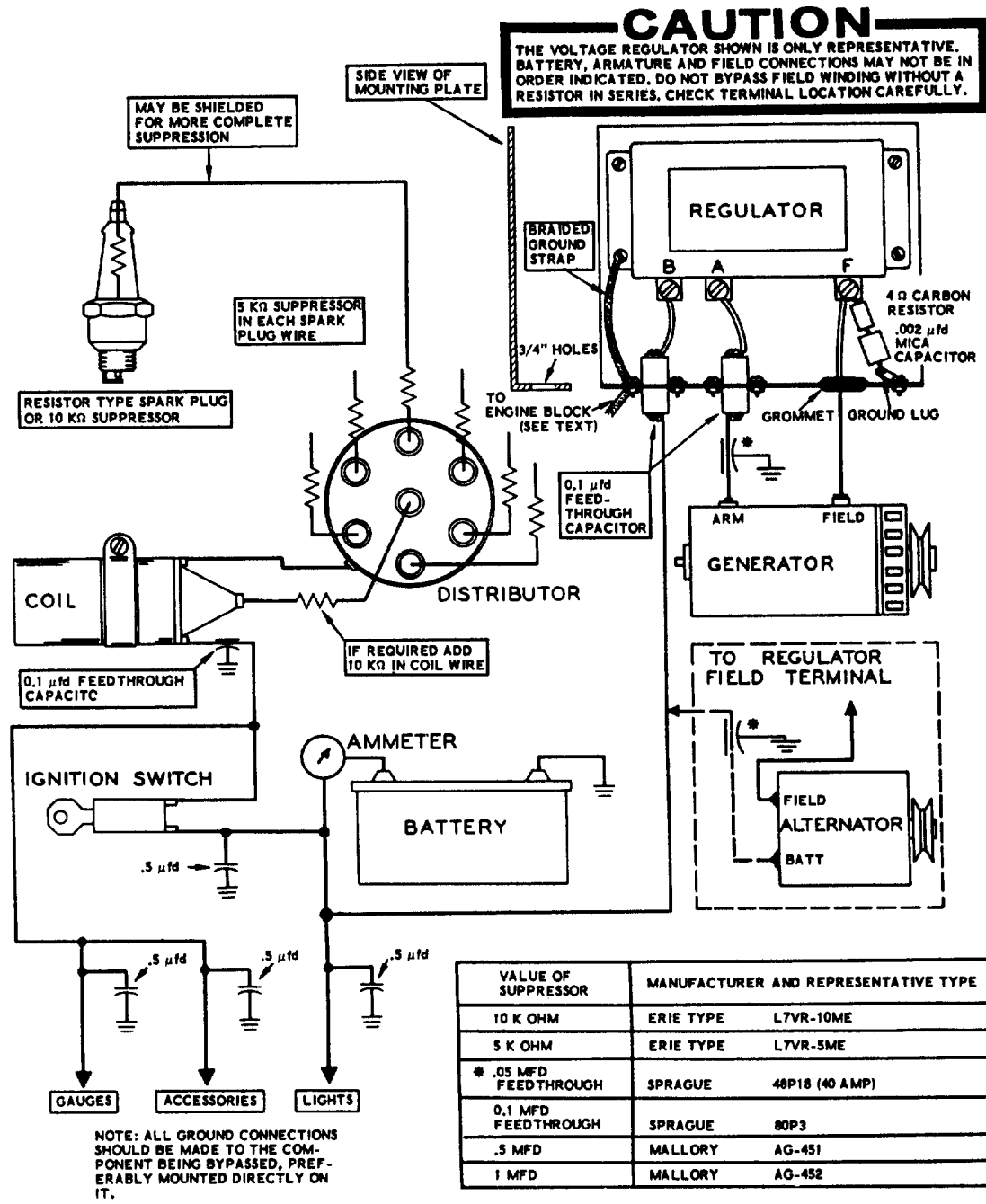

Figure 1-11

### NOISE SUPPRESSION TROUBLESHOOTING CHART

TYPE OF NOISE	PROBABLE CAUSE	RECOMMENDED REMEDY
Loud popping increasing to buzz with increased engine speed.	Ignition system.	<ol style="list-style-type: none"> <li>1. Replace plugs with resistor type. (Most recommended.)</li> <li>2. Loose crimped connections should be cleaned and soldered.</li> <li>3. Place resistors in distributor system.</li> </ol>
Whine - varies with engine speed.	Generator.	<ol style="list-style-type: none"> <li>1. 0.1 <math>\mu</math>fd coaxial type capacitor in series with the armature (A lead).</li> <li>2. Clean commutator.</li> <li>3. Replace brushes.</li> <li>4. Ground generator shaft.</li> <li>5. Parallel trap (#10 wire-coil and suitable capacitor) in series with armature lead, tuned to operating frequency.</li> </ol>
Distinct but irregular clicking noise.	Voltage regulator.	<ol style="list-style-type: none"> <li>1. 0.1 <math>\mu</math>fd coaxial type capacitor in series with the battery (B) and armature (A) leads.</li> <li>2. A series combination of a .002 <math>\mu</math>fd mica capacitor and a 4 <math>\Omega</math> carbon resistor to ground from the field (F) terminal. All components should be mounted as shown in diagram, close to voltage regulator.</li> </ol>
Same as above.	Energy transfer to primary system.	<ol style="list-style-type: none"> <li>1. Bypass at the following points: coaxial bypass in lead to coil from ignition switch (0.1 <math>\mu</math>fd). Battery lead to ammeter (.5 <math>\mu</math>fd); to gas gauge (0.5 <math>\mu</math>fd); to oil signal switch (0.5 <math>\mu</math>fd); head and tail light leads (.5 <math>\mu</math>fd); accessory wiring from engine compartment (.5 <math>\mu</math>fd).</li> </ol>
Loud popping noise that changes from one type road to another. Most pronounced on concrete.	Wheel static.	<ol style="list-style-type: none"> <li>1. Installation of front wheel static collectors (available from most automotive distributors). These should be checked every 5000 miles for excessive wear.</li> </ol>
Same as above.	Tire static.	<ol style="list-style-type: none"> <li>1. Injection of anti-static powder into tire through valve stem.</li> </ol>
Irregular popping noise when on bumpy roads, particularly at slow speeds.	Body static.	<ol style="list-style-type: none"> <li>1. Tighten all loose screws.</li> <li>2. Use heavy flexible braid and bond the engine to the frame and fire wall. Bond the control rods, speedometer cable, exhaust pipes, etc., to the frame.</li> </ol>

If an extensive amount of suppression is required, the engine should be retimed and tuned up at a reputable garage.

## OPERATION

NOTE: YOU MUST HAVE AN AMATEUR RADIO OPERATORS AND A STATION LICENSE BEFORE PLACING THE TRANSMITTER SECTION OF THE TRANSCEIVER ON THE AIR. INFORMATION ABOUT LICENSING, AND AMATEUR FREQUENCY ALLOCATIONS, IS AVAILABLE FROM PUBLICATIONS OF THE FEDERAL COMMUNICATIONS COMMISSION OR THE AMERICAN RADIO RELAY LEAGUE.

Operation of the Transceiver has been simplified as much as possible to permit rapid adjustment by the operator. Once the initial settings have been made, it should not be necessary to readjust most of the controls. Read the following information carefully. Good operating techniques will provide good clean signals and long trouble-free life of the station equipment.

CAUTION: Be sure a 50 to 75  $\Omega$  non-reactive load is connected to the ANT RF OUT jack before you operate the Transceiver. This load can be an antenna, a dummy load, or a properly adjusted linear amplifier. (See the Installation section of the Manual.)

### READING THE METER

Referring to Figure 1-12, study the meter scale and note how it reads for various positions of the Meter switch. Observe that the meter has two main scales and an ALC area.

For receiver operation, the meter operates as an S meter and reads from 0 to 60, regardless of the position of the Meter switch.

For transmit operation, the scale numbered from 0 to 10 is read directly for relative power indications. Read the 0 to 500 scale directly to read plate current in milliamperes.

### RECEIVER SECTION

Connect an 8  $\Omega$  speaker to the 8  $\Omega$  SPEAKER jack, or plug a set of headphones into the PHONES jack.

1. Set the MODE switch to either LSB or USB. NOTE: Most of the 6-meter sideband operation is on the upper sideband (USB) at the time of the writing of this Manual.
2. Set the OSC MODE switch to LMO.
3. Place the BAND switch at 50.0.

TOP EDGE OF ALC AREA REPRESENTS MAXIMUM ALLOWABLE MODULATION DETERMINED BY MICROPHONE LEVEL CONTROL

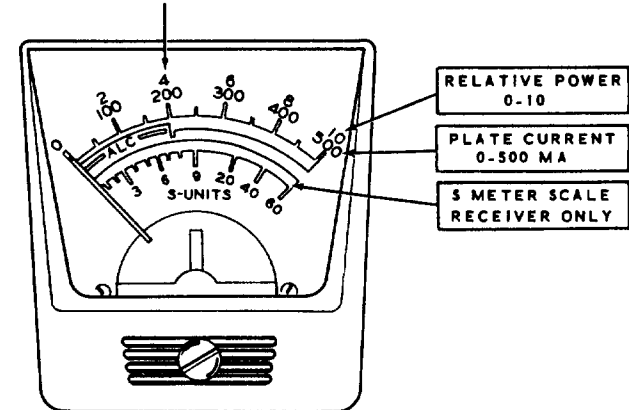

Figure 1-12

4. Turn the RF GAIN control to its fully clockwise position and pull the control knob (AGC switch) out. With the AGC switch out, a slow decay time-constant is applied to the AGC circuit. This prevents the receiver circuits from "pumping" when single sideband signals are received. When listening to extremely weak signals, use the fast decay time-constant by pushing the RF GAIN control knob in.

If an extremely strong station overloads the receiver front end, or if there are many weaker signals near the desired signal, leave the AF GAIN control set for comfortable listening; then adjust the receiver level with the RF GAIN control. This will keep the front end from overloading and mask the weaker signals that would otherwise interfere with the desired signal.

The S Meter will still read correctly with the RF GAIN set at less than maximum, if the received signal level is high enough to register on the S Meter. For example: if the RF GAIN control is set for a no-signal meter reading of S-5, and then the meter registers S-9 with a signal, the received signal is S-9.

5. Set the FUNCTION switch to PTT and allow the Transceiver to warm up.

6. Adjust the AF GAIN control clockwise until some receiver noise is heard.

NOTE: The AF GAIN control adjusts the overall receiver (speaker and headphones) volume. When headphones are used, set the HEADPHONE LEVEL control to the same relative level as the speaker. Then regardless of whether a speaker or headphones are used, only the AF GAIN control need be changed for different volume levels.

7. Adjust the PRESELECTOR control for peak noise from the receiver. NOTE: If this control peaks outside of its range after an antenna is connected, the antenna transmission line is not matched and this condition should be corrected. For slight mismatches, readjust receiver antenna coil L1 with the antenna connected. Be sure when making this adjustment, that the PRESELECTOR control is set as outlined in the Alignment section.

8. The Transceiver is now ready to receive. Turn the BAND switch to select the desired 500 kc band segment. The frequency of the tuned signal is determined by adding together the settings of the BAND switch, the slide rule pointer, and the circular dial.

9. Turn the FUNCTION switch to CAL. Rotate the Main Tuning dial (LMO) to the nearest 100 kc point (0 on the circular dial).

Adjust the Main Tuning dial until the calibrate signal is at zero beat. (To be sure that the correct calibrate signal is being used, turn the BAND switch to the next position and back again while listening for the characteristic "chirp.") When the calibrate signal is at zero beat, set the hairline over the "0" mark on the circular dial with the zero set knob. Now return the FUNCTION switch to the PTT position.

10. If strong noise pulses interfere with weak signals, turn on the noise limiter by pulling out on the AF GAIN control. It may also be necessary to increase the setting of the AF GAIN control. NOTE: Signal distortion increases when the noise limiter circuits receive large input signals. This is true of most noise limiter circuits. However, a signal that is large enough to cause excessive distortion usually overrides the noise, so the noise limiter is not needed.

This noise limiter is very effective with weak signals when high impulse noise is encountered. However, with the limiter turned on and with a strong signal input, there will be some compression of the output signal and lowering of the S meter reading.

WARNING: The first 100 kc portion of the 6-meter band, 50.0 to 50.1 mc, is for CW operation only. Do not operate the transmitter (with modulation) in the VOX or PTT modes, if the receiver is tuned to this portion of the band and the OSC MODE switch is in the LMO position, or the transmitted signal will be outside of the phone part of the band. (When the OSC MODE switch is in the LMO position, the transmitter and receiver always operate on the same frequency.)

## TRANSMITTER SECTION

### Initial Tune Up

The first 13 steps of this procedure must be performed for all modes of operation.

1. Set the BAND switch and Main Tuning dial for the desired frequency.
2. Place the METER switch in the PLATE position.
3. Turn the MIC/CW LEVEL control fully counterclockwise.
4. Set the OSC MODE switch to LMO. If crystal control of the transmitter is used, set the OSC MODE switch to AUX T. (See the Special Crystal Considerations section of the Manual.)
5. With the RF load connected to the ANT RF OUT jack, set the MODE switch to TUNE. The meter should read 50 ma.

CAUTION: For the following setups, do not leave the transmitter on at full output for extended periods of time, or the final amplifier tubes and/or the power supply may be damaged.

6. Advance the MIC/CW LEVEL control for a plate current reading of 100 to 150 ma. Turn the FINAL tuning control (round knob) immediately, for minimum plate current.



7. Adjust the DRIVER control for peak plate current. If the plate current exceeds 250 ma, reduce the MIC/CW LEVEL control.
8. Keep advancing the MIC/CW LEVEL control, while maintaining plate current, until the final amplifiers are loaded to 250 ma.
9. Set the METER switch to REL PWR.
10. Adjust the FINAL loading control (lever knob) for a peak meter reading. Readjust the FINAL tuning control for a peak meter reading.
11. Return the METER switch to the PLATE position. Readjust the MIC/CW LEVEL control, for 250 ma maximum plate current. IMPORTANT: Observe while turning the MIC/CW LEVEL control clockwise, that the plate current and relative power readings reach a saturation point. Further increase in the setting of this control will show little or no increase in meter readings. Be sure this control is set just below the saturation point. Setting beyond this point will cause a time lag when changing from transmit to receive operation.
12. Return the MIC/CW LEVEL control to its full counterclockwise position.
13. Place the MODE switch in the position for the desired mode of operation: USB, LSB, or CW.

CAUTION: If the frequency of the Transceiver is changed by any great amount, be sure to readjust the DRIVER, FINAL Tuning, and Loading controls.

This completes the Initial Tune Up. Before placing the Transceiver in operation, complete either the following CW or Single Sideband adjustments.

### CW Operation

For CW operation the FUNCTION switch can be set to either the PTT or VOX positions.

Be sure steps 1 through 11 have been satisfactorily completed before proceeding with the following adjustments.

14. Place the MODE switch in the CW position.
15. Plug a key into the KEY jack.
16. While holding the key down, adjust the VOX control until the relays operate.
17. While sending a series of "Vs," adjust the DELAY control so the relays stay energized between each group of characters. Clockwise rotation of this control will increase the holding time of the relays.  
  
The final setting of the DELAY control will be determined by the sending speed of the operator. The slower the sending speed, the higher the setting of this control. NOTE: Be sure the DELAY control is adjusted so the relays do not open after each character is sent.
18. Hold the key down and adjust the SIDETONE LEVEL control for a comfortable monitoring level. NOTE: The VOX control also affects the side tone monitoring level. Be sure the VOX control is set just high enough to close the relays when the key is depressed.

NOTE: The frequency of the CW output signal is 800 cycles higher than the dial reading. The received signal is actually in the USB position, even though the MODE switch is set at CW. Consequently, cross-mode operation is possible between USB and CW without any resetting of the Main Tuning dial. For example, if two stations begin operation in the USB mode of operation and one operator decides to change to CW, the other station will hear an 800 cycle note without retuning his receiver. Also, the station operating in the CW mode will receive the USB signal from the other station without changing back to the USB position of the MODE switch.

## Single Sideband Operation

Be sure steps 1 through 13 have been satisfactorily completed before proceeding with the following adjustments.

14. Set the MODE switch to either the USB or LSB position.
15. Set the BAND switch and the Main Tuning dial to the desired operating frequency.
16. Connect a microphone to the MIC connector.
17. Place the FUNCTION switch in the PTT position. (If your microphone does not have push-to-talk capabilities, make the VOX adjustments first, and then proceed with step 18.)
18. Set the METER switch to ALC.
19. Actuate the transmitter (PTT or VOX) and while speaking into the microphone, turn the MIC/CW LEVEL control clockwise until the peak deflections register at about S3 on the meter. Do not allow the meter to deflect beyond the top of the ALC (S8) region on the meter.

## VOX Adjustments

The VOX, ATG, and DELAY controls are located on the front of the final amplifier shield, under the cabinet cover.

- ( ) Turn the MIC/CW LEVEL control fully counterclockwise. Leave this control in this position for the following adjustments.

- ( ) Set the FUNCTION switch to VOX.

NOTE: Close-talk into the microphone when using VOX operation to prevent background noise from tripping the Transceiver into transmit operation.

- ( ) While speaking into the microphone, turn the VOX control to just beyond a setting that will energize the relays. Be sure this control is not set so high that it will allow background noise to trip the relays.
- ( ) Tune the receiver to a fairly strong signal and adjust the AF GAIN control for a comfortable listening level.
- ( ) Place the microphone where it will normally be used. Advance the ATG (anti-trip gain) control to just beyond a setting that will keep the speaker signal from tripping the relays (through the microphone and VOX circuits). Be sure this control is not set so high that it completely disables the relay closing action.
- ( ) While speaking into the microphone, turn the DELAY control to a setting that will hold the relays energized during the slight pauses between words. This prevents the relays from tripping at the beginning and end of each word.

NOTE: There will be a slight interaction between the VOX, ATG, and DELAY controls. Consequently, it may be necessary to readjust these controls slightly to achieve the desired results.

The Transceiver is now ready for transmit operation in the SSB mode. Speaking into the microphone (VOX) or using the microphone push-to-talk switch (PTT) will change the Transceiver from receive to transmit operation. Remember, as long as the OSC MODE switch is in the LMO position, the receiver and transmitter are locked on the same frequency.

### OPERATION WITH A LINEAR AMPLIFIER

Operation with a linear amplifier is similar to operation with an antenna at the output of the Transceiver, except that the linear amplifier input may have a different impedance. This will make it necessary to adjust the FINAL Tuning and Loading controls for maximum output (input to the linear amplifier). Figure 1-10 on Page 101 shows the proper connections between a linear amplifier and the Transceiver.

### MOBILE OPERATION

If the Heathkit Model HP-13A Power Supply is to be used with the Transceiver in a mobile installation and the BIAS control in the Transceiver has already been preset for fixed station operation, make the following adjustments.

- ( ) Turn the MIC/CW LEVEL control fully counterclockwise.
- ( ) Place the MODE switch in either the USB or LSB position.
- ( ) Set the FUNCTION switch to PTT.
- ( ) Place the METER switch in the PLATE position.

NOTE: The following adjustment should be made with the automobile engine running at an idle, and will require the aid of another person.

Activate the transmitter with the push-to-talk button on the microphone, and adjust the bias control in the HP-13A Power Supply for a plate current reading of 50 ma. This will make it unnecessary to readjust the BIAS control of the Transceiver each time it is changed from mobile to fixed station use.

The VOX, DELAY, and ATG circuits will operate in mobile use, but because of the different power supplies, it may be necessary to readjust these controls. For VOX operation, leave clearance in the mobile installation so the Transceiver cover can be opened to make these adjustments.

Transmitter loading may be somewhat more critical on mobile antennas because of their sharper frequency characteristics. Consequently, the mobile antenna should be tuned as close as possible to the desired operating frequency.

WARNING: Measure the output voltage of the vehicle generator or alternator. This output voltage must not exceed 14.5 volts. The LV B+ from the Power Supply should not exceed 290 volts. If either of the above voltages exceed these limits, it will be necessary to have the voltage regulator adjusted for a maximum of 14.5 volts DC output from the charging system. Failure to do this will result in shortened component life, inoperative VOX, and possible instability of the Transceiver.

## IN CASE OF DIFFICULTY

Refer to the Kit Builders Guide for Service and Warranty information.

NOTE: At no time should the LMO be opened or the Warranty will be voided. The LMO was aligned using the tube supplied. Changing this tube may cause some slight difference in calibration. Replace the tube with one of the same brand if replacement is necessary.

Refer to the Schematic Diagram (fold-out from Page 149) and to the Chassis Photos and X-Ray Views (Pages 147 to 150) for the locations of parts.

Check the voltage and resistance readings in the Transceiver against the readings shown in Figure 1-13 (fold-out from Page 111) and Figure 1-14 (fold-out from Page 112). All voltage readings were taken with an 11 megohm input vacuum tube voltmeter. Voltages may vary as much as 10%.

NOTE: Breaks in the foil of the circuit boards can easily be detected by placing a bright light under the foil side of the board and looking through the board from the lettered side. A break will appear as a hair-line crack in the foil.

Wiring errors are the most common cause of difficulty. Therefore, the first step in troubleshooting is to recheck all wiring against the Pictorials and Schematic diagrams. Often having a friend check the wiring will locate an error consistently overlooked.

Quite often soldered connections that appear good will have an insulating coating of rosin between the wire, the terminal, and the solder. This results from insufficient heat being applied when soldering. Many troubles can be eliminated by reheating each connection to make sure that it is properly soldered as illustrated in the Proper Soldering Techniques section of the Kit Builders Guide. The power cable should be removed from the power supply for such tests. As additional insurance against shock, a screwdriver blade should be used to short from the chassis to the hot ends of all electrolytic filter capacitors in the power supply.

If fuses blow instantly when power is applied to the unit, make resistance checks of the power supply, B+ circuits, and filament circuits. Check all tubes for possible shorts. Also refer back to the resistance checks on Page 82, and Initial Test section on Page 88. Check to be sure that all tubes are in their proper locations.

Be sure to read the Circuit Description so that "Cause-and-Effect" reasoning may be employed as the search for the trouble progresses. If some difficulty still persists after the steps outlined in the Troubleshooting Chart have been completed, try to localize the trouble to a particular stage in the circuit by using the voltage and resistance charts. Then refer to the Block Diagram and Schematic to visualize circuit relationships.

A grid dip meter or wavemeter and a general coverage receiver are ideal instruments for checking operation of the RF circuits.

NOTE: If there is instability in the unit, check all circuit board mounting screws. These screws should be tight to the chassis and to the circuit board. Be sure lockwashers are against the foil side of the boards for good grounding.

The relays used in this unit ordinarily will be troublefree for several years of normal use. However, if the Transceiver is exposed to wind blown dust, difficulty may be encountered with foreign matter lodging between the contacts. Using compressed air often removes such foreign matter. If it has caused contact arcing, the contacts should be cleaned with a burnishing tool only. DO NOT TRY TO USE PAPER, FINGER NAIL BOARDS OR LIQUID CONTACT CLEANERS. Further damage of the contacts will only result by using these items.

DO NOT REMOVE ANY OF THE TUBES OR PILOT LAMPS WITH POWER APPLIED TO THE UNIT. Because of the series-parallel filament circuit arrangement when using a 12 volt supply, removing a tube with power applied may destroy other tubes due to an increase in a filament current through them.

## TROUBLESHOOTING CHART

NOTE: References will often be made to previous Symptoms and Causes. Therefore, each Symptom is identified by a number, and each Possible Cause has an identifying letter. If you are directed, for example, to "check item 1C," refer to Symptom number 1, Possible Cause C.

### GENERAL

SYMPTOMS	POSSIBLE CAUSES
1. No power, pilot lamps do not light, filaments do not light, no B+ voltage, no bias voltage.	<ul style="list-style-type: none"> <li>A. Power plug wired incorrectly.</li> <li>B. Power cable from power supply wired incorrectly.</li> <li>C. Defective AC snap switch on Function switch.</li> <li>D. In mobile installation, power supply leads to battery reversed.</li> <li>E. Fuses or circuit breakers open.</li> <li>F. Defective power supply.</li> </ul>
2. Pilot lamps and filaments light, but no bias or B+ voltage.	<ul style="list-style-type: none"> <li>A. Check items 1A and 1B.</li> <li>B. Rectifiers defective in power supply.</li> <li>C. Transformer defective in power supply.</li> </ul>
3. Bias and B+ voltage ok, but pilot lamps and filaments not lit.	<ul style="list-style-type: none"> <li>A. Check items 1A, 1B and 2C.</li> <li>B. Brn wire from power plug CC6 to terminal strip EG5 open or wired incorrectly.</li> </ul>
4. Low filament voltage on V1 and V2.	<ul style="list-style-type: none"> <li>A. Wht and brn leads reversed at points A and B on Receiver RF circuit board.</li> </ul>
5. No regulated B+ voltage (+150).	<ul style="list-style-type: none"> <li>A. Incorrect wiring on tube socket V16.</li> <li>B. Bad OA2 regulator tube, V16.</li> <li>C. Open or incorrectly wired resistor R160.</li> </ul>
6. Regulated B+ voltage too high.	<ul style="list-style-type: none"> <li>A. Check items 5A and 5B.</li> <li>B. Resistor R160 wrong value.</li> </ul>
7. Regulated B+ voltage too low.	<ul style="list-style-type: none"> <li>A. Check items 5B and 6B.</li> </ul>

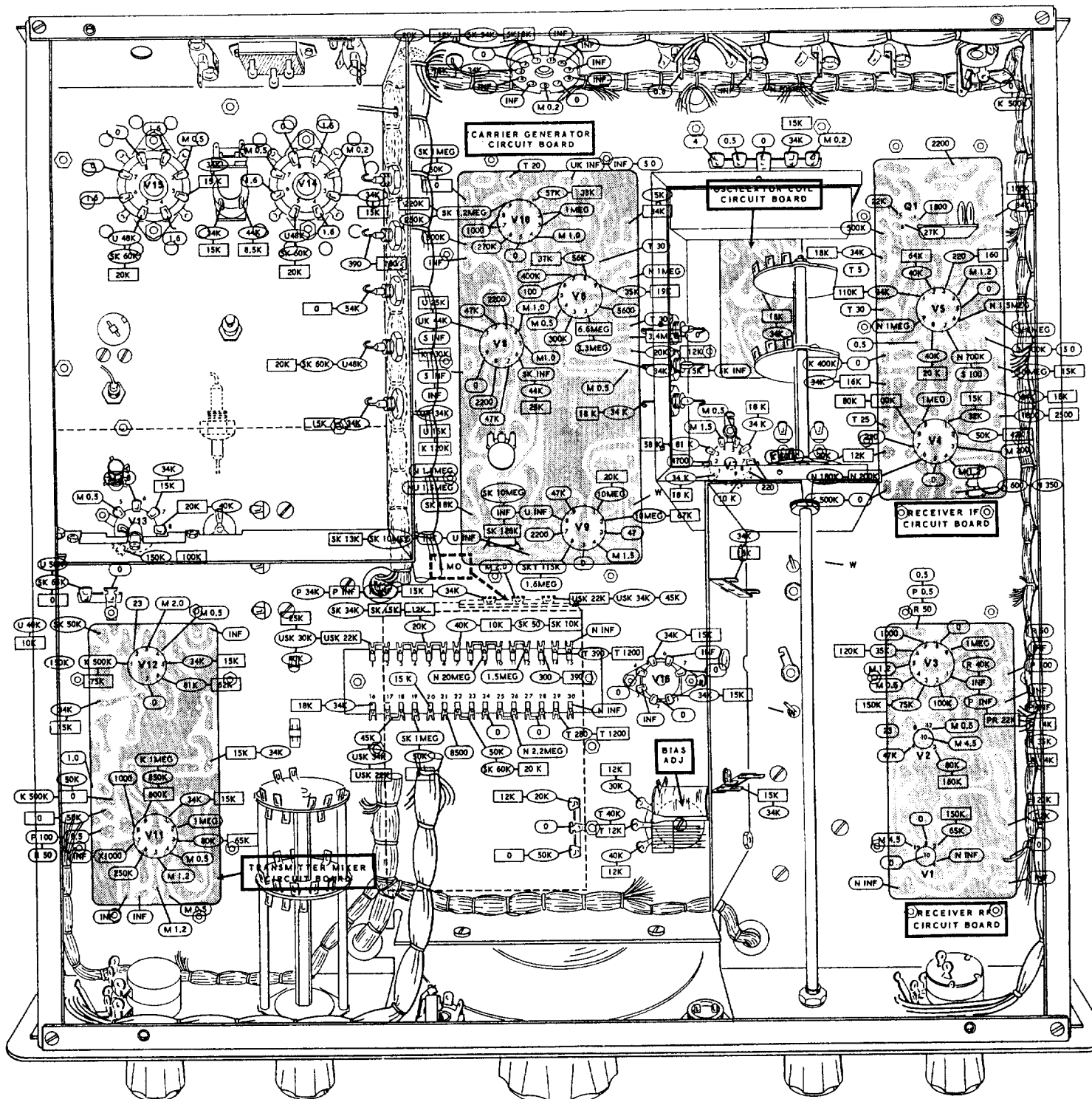

## RESISTANCE CHART

NOTE: THESE MEASUREMENTS WERE MADE WITH ALL TUBES INSTALLED AND THE POWER SUPPLY DISCONNECTED.

- K. MODE SWITCH IN CW POSITION.
- M. THESE READINGS ARE OF THE FILAMENT LINE AND MAY VARY FROM THOSE LISTED DEPENDING ON TYPE OF OHMMETER USED.
- N. BECAUSE OF THE SOLID STATE DIODES USED IN THESE CIRCUITS, READINGS MAY VARY FROM THOSE LISTED, DEPENDING ON OHMMETER RANGE SELECTED AND TYPE OF OHMMETER USED. SELECT THE LOWEST METER RANGE THAT WILL GIVE A READABLE INDICATION. NOTE: IT MAY BE NECESSARY TO REVERSE METER LEADS.)
- P. OSC MODE SWITCH IN AUX T POSITION.
- R. OSC MODE SWITCH IN XTAL POSITION.
- S. MODE SWITCH IN TUNE POSITION.
- T. INDICATES THERE IS A POTENTIOMETER IN THE CIRCUIT. READINGS WILL VARY FROM THOSE LISTED DEPENDING ON SETTING OF THE POTENTIOMETER.
- U. MODE SWITCH IN USB POSITION.
- W. READINGS INDETERMINATE.
- X. FUNCTION SWITCH IN CAL POSITION.

- INDICATES RESISTANCE WITH RELAY RL1 IN RECEIVE POSITION.
  - ◻ INDICATES RESISTANCE WITH RELAY RL1 IN TRANSMIT POSITION. (THIS IS ACCOMPLISHED BY PUSHING IN ON THE END OF THE RELAY.)
  - ◌ INDICATES RESISTANCE REGARDLESS OF RELAY DE POSITION.
- ALL POTENTIOMETER CONTROLS ARE SET AT FULL COUNTERCLOCKWISE POSITIONS, EXCEPT FOR THE RF GAIN CONTROL WHICH IS AT ITS FULL CLOCKWISE POSITION.
- MODE SWITCH IS NORMALLY IN THE LSB POSITION UNLESS THE LEGEND ABOVE INDICATES OTHERWISE.
- FUNCTION SWITCH IS NORMALLY IN THE PTT POSITION UNLESS THE LEGEND ABOVE INDICATES OTHERWISE.
- OSC MODE SWITCH IS NORMALLY IN THE LMO POSITION UNLESS THE LEGEND ABOVE INDICATES OTHERWISE.
- METER SWITCH IS NORMALLY IN THE PLATE POSITION.
- ALL RESISTANCE CHECKS ARE MEASURED FROM POINT INDICATED TO GROUND.

FIGURE 1.14

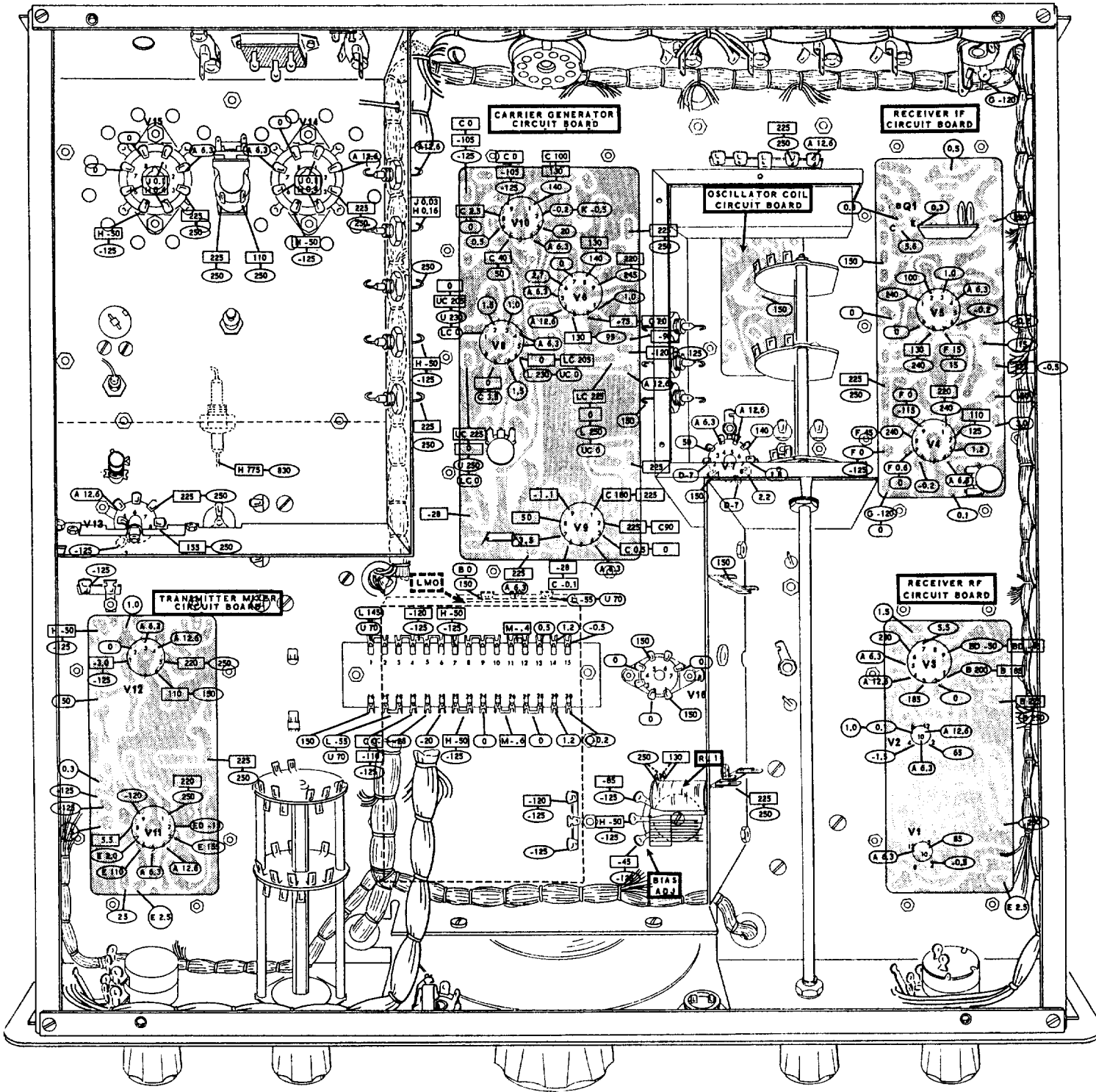

### VOLTAGE CHART

- A. FILAMENT VOLTAGE, MAY BE AC OR DC DEPENDING ON POWER SUPPLY SOURCE.
- B. WITH OSC. MODE SWITCH IN XTAL POSITION AND WITH CRYSTAL IN SOCKET.
- C. WITH MODE SWITCH IN EITHER USB OR LSB AND TRANSMITTER ACTIVATED BY PTT.
- D. THESE VOLTAGE READINGS ARE DUE TO RF RECTIFICATION AND MAY VARY ±50% FROM THE LISTED VOLTAGES.
- E. WITH FUNCTION SWITCH IN CAL POSITION.
- F. WITH FUNCTION SWITCH IN VOX POSITION.
- G. WITH MODE SWITCH IN CW POSITION.
- H. VOLTAGE WILL VARY, DEPENDING ON BIAS CONTROL SETTING, BUT SHOULD BE AS INDICATED FOR NORMAL TRANSMIT OPERATION.
- J. SMALLER VOLTAGE INDICATION CORRESPONDS TO 50 MA FINAL AMPLIFIER PLATE CURRENT, LARGER VOLTAGE INDICATION CORRESPONDS TO 250 MA FINAL AMPLIFIER PLATE CURRENT.
- K. MODE SWITCH IN CW POSITION.
- L. MODE SWITCH IN LSB POSITION.
- M. THESE VOLTAGE READINGS REQUIRE TWO TONE TEST SIGNAL INPUT AND WILL VARY DEPENDING ON INPUT AUDIO LEVEL.
- U. MODE SWITCH IN USB POSITION.

- INDICATES VOLTAGE IN RECEIVE OPERATION ONLY (MODE SWITCH IN EITHER USB OR LSB POSITION).
- INDICATES VOLTAGE IN TRANSMIT OPERATION ONLY (MODE SWITCH IN TUNE POSITION).
- INDICATES VOLTAGE IN RECEIVE OR TRANSMIT OPERATION.
- INDICATES RMS VALUE OF RF VOLTAGE AND MAY VARY ±50% FROM THE LISTED VOLTAGE.

ALL VOLTAGE READINGS TAKEN WITH THE **CW** LEVEL CONTROL IN ITS FULLY COUNTERCLOCKWISE POSITION. THE FUNCTION SWITCH IS NORMALLY IN THE PTT POSITION UNLESS THE LEGEND ABOVE INDICATES OTHERWISE.

THE OSC MODE SWITCH IS NORMALLY IN THE LMO POSITION UNLESS THE LEGEND ABOVE INDICATES OTHERWISE.

ALL VOLTAGES ARE MEASURED FROM POINT INDICATED TO GROUND WITH AN 11 MEGOHM INPUT VTVM. VOLTAGES MAY VARY ±50%.

ALL VOLTAGES ARE POSITIVE UNLESS MARKED OTHERWISE.

FIGURE 1.13

SYMPTOMS	POSSIBLE CAUSES
8. No receiver B+ voltage, other voltages ok.	<ul style="list-style-type: none"> <li>A. Relay DE contacts 17 and 18 open or dirty.</li> <li>B. Org-wht and red leads reversed to relay DE contacts 16 and 17.</li> <li>C. Org-wht and red-wht leads reversed to relay DE contacts 16 and 18.</li> </ul>
9. No audio output at speaker or headphones.	<ul style="list-style-type: none"> <li>A. Check items 5A, 5B, 5C, 8A, 8B, and 8C.</li> <li>B. Defective output transformer T4.</li> <li>C. Resistor R68 open or wrong value.</li> <li>D. Filter capacitor C67 shorted or installed backwards.</li> <li>E. Audio output amplifier tube V6 defective.</li> <li>F. Defective transistor Q1, or transistor installed backwards.</li> <li>G. Blk and/or brn shielded cables connected to AF GAIN control (FJ) shorted.</li> <li>H. Relay DE contacts 2 and 3 open or dirty.</li> <li>I. Gry and blk leads reversed to contacts 1 and 2 of relay DE.</li> <li>J. Gry and blk-wht leads reversed to contacts 1 and 3 of relay DE.</li> <li>K. PHONES socket wired incorrectly.</li> </ul>
10. No audio output from speaker but headphone output ok.	<ul style="list-style-type: none"> <li>A. Contacts 1 and 2 on phone jack (NH) open.</li> <li>B. Blk-gry-wht and blu-wht leads reversed to lugs 1 and 4 of phone jack (NH).</li> <li>C. Gry-wht and blk-gry-wht leads reversed to phono sockets ED (ALC) and EA (8 <math>\Omega</math> SPEAKER).</li> <li>D. Gry-wht and blk-gry-wht leads reversed between phono socket ED (ALC) and lug 2 of terminal strip EG.</li> <li>E. Speaker lead connected to wrong phone socket.</li> <li>F. Defective speaker.</li> </ul>
11. Low or no audio output from headphones but speaker output ok.	<ul style="list-style-type: none"> <li>A. HEADPHONE LEVEL control set in its full counterclockwise position.</li> <li>B. Blk-gry-wht and blu-wht leads reversed between phone jack NH lugs 2 and 4. (Also check item 10B.)</li> <li>C. Grn-wht and blk-gry-wht leads reversed between lugs 1 and 2 of terminal strip EG.</li> <li>D. Grn-wht and gry-wht leads reversed between terminal strip EG lug 1 and phono socket ED (ALC).</li> <li>E. Defective headphones.</li> </ul>



SYMPTOMS	POSSIBLE CAUSES
<p>12. No signal or noise output, but very low hum output can be heard (speaker or phones).</p>	<ul style="list-style-type: none"> <li>A. Check items 9A, 9F, 9G, 9H, 9I and 9J.</li> <li>B. RFC1 open.</li> <li>C. Product detector diodes GD200, GD201, GD202, and GD203 wired incorrectly or defective.</li> <li>D. No carrier generator injection signal at product detector. (Check items 29A through 29F.)</li> <li>E. Red coaxial cable connected at point 1 on receiver IF circuit board open or shorted.</li> <li>F. IF transformer T3 defective or misaligned.</li> <li>G. Noise limiter circuit board installed improperly on receiver IF circuit board or diodes SD50 and SD51 incorrectly wired or defective.</li> <li>H. Second IF amplifier tube V5A (6AZ8) defective.</li> <li>I. First transmitter mixer tube V11 (6EA8) has open filament.</li> </ul>
<p>13. No signal output, but noise output can be heard.</p>	<ul style="list-style-type: none"> <li>A. IF transformer T2 defective or misaligned.</li> <li>B. Crystal filter Y5 defective.</li> <li>C. No LMO injection signal at the cathode of V3A. (Check items 30A through 30F.)</li> <li>D. Yel coaxial cable connected at point 1 on the receiver RF circuit board shorted or open.</li> <li>E. First IF amplifier tube V4A (6AZ8) defective.</li> <li>F. Second receiver mixer tube V3A (6EA8) defective.</li> <li>G. Bandpass coupler T1 defective.</li> <li>H. Capacitors C22 and C31 wrong value.</li> <li>I. No heterodyne oscillator injection signal at cathode of V2. (Check items 32A through 32G.)</li> <li>J. Red coaxial cable at point 3 on receiver RF circuit board open or shorted.</li> <li>K. First receiver mixer V2 or RF amplifier V1 (6DS4's) defective. Also check item 4A.</li> <li>L. Grn coaxial cable at point 4 on receiver RF circuit board open or shorted.</li> <li>M. Antenna relay RL2 or ANT RELAY switch wired incorrectly. Open or dirty contacts.</li> </ul>
<p>14. Audio output with signal, but weak.</p>	<ul style="list-style-type: none"> <li>A. Low B+ supply voltage.</li> <li>B. Coils L1, L2, L3, and L4 misaligned.</li> <li>C. Check items 4A, 7A, 12B through 12I, 13A through 13M.</li> <li>D. RF GAIN control is full counterclockwise or wired incorrectly.</li> </ul>

SYMPTOMS	POSSIBLE CAUSES
15. Receiver tends to be unstable, oscillates, (Receiver noise may be extremely high, or "birdies" appear across tuning range.)	<ul style="list-style-type: none"> <li>A. Neutralization coil L2 misaligned.</li> <li>B. PRESELECTOR tuning capacitor mounting hardware not tight.</li> <li>C. Receiver RF and IF circuit board mounting hardware not tight, or lockwashers left out from between the chassis and circuit board.</li> <li>D. Antenna transmission line either open or shorted, or has high SWR.</li> <li>E. Supply voltage too high (see warning on Page 109). Also check items 6A and 6B.</li> </ul>
16. Sideband reception reversed or highly distorted.	<ul style="list-style-type: none"> <li>A. Carrier generator crystals Y7 and Y8 interchanged.</li> <li>B. CW carrier generator crystal Y9 interchanged with either Y7 or Y8.</li> <li>C. Gry-wht and blu-wht leads reversed between lugs 22 and 18 of MS1R.</li> </ul>
17. S-meter inoperative, or indicates backwards, or is inoperative in some meter switch positions, or does not zero.	<ul style="list-style-type: none"> <li>A. Two yel leads connected to the meter terminals reversed.</li> <li>B. Improper wiring at METER switch.</li> <li>C. Relay DE contacts 14 and 15 open or dirty.</li> <li>D. Wht and yel leads reversed to relay DE contacts 13 and 14.</li> <li>E. S METER "0" ADJ and/or ALC METER ADJ improperly adjusted.</li> <li>F. One of the following resistors is a wrong value: R42, R43, R44, R52, R53, R54, R230, or R231.</li> <li>G. 30-lug terminal strip improperly wired or some interconnecting segments left between lugs. (See Pictorial 3-12).</li> <li>H. First or second IF amplifier tubes (V4A or V5A) defective.</li> </ul>

#### TRANSMITTER

SYMPTOMS	POSSIBLE CAUSES
18. No transmitter B+ voltage (other voltages ok).	<ul style="list-style-type: none"> <li>A. Relay DE not energized. Check items 33A through 33E, 34A through 34G.</li> <li>B. Relay DE contacts 16 and 17 open or dirty.</li> <li>C. Red and red-wht leads reversed to contacts 17 and 18 of relay DE.</li> <li>D. Org-wht and red-wht leads to relay DE contacts 16 and 18 reversed.</li> </ul>
19. Bias voltage does not shift to operating levels in transmit conditions.	<ul style="list-style-type: none"> <li>A. Check item 18A.</li> <li>B. Relay DE contacts 1 and 2 open or dirty.</li> <li>C. Blk and blk-wht leads reversed to contacts 2 and 3 of relay DE.</li> <li>D. Gry and blk-wht leads reversed to contacts 1 and 3 of relay DE.</li> <li>E. 30-lug terminal strip improperly wired or some interconnecting segments left between lugs. Check between lugs 6 and 7. (See Pictorial 3-12 and detail.)</li> <li>F. Resistors R125, R127 or Bias Adj control wrong values.</li> <li>G. BIAS ADJ control set improperly.</li> </ul>

SYMPTOMS	POSSIBLE CAUSES
<p>20. No RF output from final, regardless of MODE switch position. (Driver output appears to be ok.)</p>	<ul style="list-style-type: none"> <li>A. High voltage B+ missing from plates of final amplifier tubes V14 and V15.</li> <li>B. RF choke RFC6 open.</li> <li>C. Resistor R151 not connected at feedthrough capacitor AU.</li> <li>D. Antenna relay AE not energized or contacts 1 and 2 open or dirty. Also check items 33A through 33E, 34A through 34G.</li> <li>E. Bias voltage too high at grids of V14 and V15. (Check items 19B through 19G.)</li> <li>F. FINAL and Loading controls not adjusted properly.</li> <li>G. Coaxial cable from loading capacitor LF to antenna relay AE open or shorted.</li> <li>H. Final amplifier tubes V14 and/or V15 defective.</li> </ul>
<p>21. No RF output from driver regardless of MODE switch position. (Second transmitter mixer output appears to be ok.)</p>	<ul style="list-style-type: none"> <li>A. B+ voltage missing from plate of driver tube V13. Check items 18A through 18D.</li> <li>B. RF choke RFC4 open.</li> <li>C. Resistor R132 not connected at feedthrough capacitor AU.</li> <li>D. Bias voltage too high at grid of V13. Check items 19B through 19G.</li> <li>E. Coils L14, L15, and L16 misaligned.</li> <li>F. DRIVER tuning control not adjusted properly.</li> <li>G. Driver tube V13 defective.</li> </ul>
<p>22. No RF output from second transmitter mixer, regardless of MODE switch position. (First transmitter mixer output appears to be ok.)</p>	<ul style="list-style-type: none"> <li>A. Check items 5A, 5B, 5C, 18A through 18D, 19B through 19G, 21E and 21F.</li> <li>B. No heterodyne oscillator injection signal at the cathode of V12. (Check items 32A through 32G.)</li> <li>C. Red coaxial cable connected at point 1 on the transmitter mixer circuit board either open or shorted.</li> <li>D. Second transmitter mixer tube V12 defective.</li> <li>E. LMO tube V17 has open filament.</li> </ul>
<p>23. No RF output from first transmitter mixer regardless of MODE switch position. (First IF amplifier output appears to be ok.)</p>	<ul style="list-style-type: none"> <li>A. Check items 18A through 18D, and 19B through 19G.</li> <li>B. No LMO oscillator injection signal at the cathode of V11B. (Check items 30A through 30E.)</li> <li>C. Blu coaxial cable, connected at point 3 on the transmitter mixer circuit board, either open or shorted.</li> <li>D. Capacitors C117, C118, and/or C120 wrong values.</li> <li>E. Bandpass coupler T6 defective.</li> <li>F. First transmitter mixer tube V11B defective.</li> <li>G. Second IF amplifier tube V5 has open filament.</li> </ul>

SYMPTOMS	POSSIBLE CAUSES
<p>24. No RF output from first IF amplifier regardless of MODE switch position. (Isolation amplifier output appears to be ok.)</p>	<p>A. Check items 13A, 13B, 13E, and 18A through 18D.  B. Brn coaxial cable, connected at point 4 on receiver IF circuit board, either open or shorted.  C. Relay DE contacts 4 and 5 open or dirty.  D. Brn-wht, and grn leads reversed between contacts 5 and 6 of relay DE.  E. Gry-wht, and grn leads reversed between contacts 4 and 6 of relay DE.  F. Resistors R40, R41, R42, R43, R230, and/or S-METER "0" ADJ control wrong values.</p>
<p>25. No RF output from isolation amplifier, regardless of MODE switch position.</p>	<p>A. Check items 18A through 18D and 19B through 19F.  B. Blu and brn leads reversed to lugs 17 and 19 of wafer MS2F.  C. Resistors R95, R96, R97, R98, R223, and/or R224 wrong values.  D. 30-lug terminal strip improperly wired, or some interconnecting segments left between lugs. Check between lugs 19 and 20, 20 and 21.  E. Transformer T5 defective or misaligned.  F. Isolation amplifier tube V9B defective.</p>
<p>26. No RF output with MODE switch in USB or LSB, but output ok in TUNE or CW positions.</p>	<p>A. Check items 9C, 9D, 9E, 19A through 19F, 25A through 25E.  B. No carrier generator injection signal to balanced modulator. (Check items 29A through 29F).  C. Balanced modulator diodes GD220, GD221, GD222 and GD223 either wrong type, installed improperly, or defective .  D. RF choke RFC2 or RFC3 open.  E. CARRIER BAL ADJ and CARRIER NULL ADJ misaligned.  F. Yel coaxial cable, from MIC CW LEVEL control to point 4 on carrier generator circuit board, either open or shorted.  G. Blk coaxial cable, from MIC CW LEVEL control to point 3 on carrier generator circuit board, either open or shorted.  H. Yel coaxial cable, from lug 4 of wafer MS1F to point 5 on carrier generator circuit board, either open or shorted.  I. Blk coaxial cable, from the MIC connector to lug 21 of wafer MS1F, either open or shorted.  J. Wafer MS1F wired incorrectly.  K. MIC connector wired incorrectly.  L. Microphone amplifier-cathode follower tube V10 defective.  M. Defective microphone.</p>

SYMPTOMS	POSSIBLE CAUSES
<p>27. No RF output with MODE switch in TUNE or CW, but output ok in LSB or USB.</p>	<p>A. Check items 18A through 18D, 19B through 19F, 25B through 25E, and 28A through 28E.</p>
<p>28. No carrier generator injection signal with MODE switch in TUNE or CW position. (LSB and USB output ok.)</p>	<p>A. CW crystal Y9 improper frequency or defective.            B. Capacitors C90, C91, C92 wrong value.            C. Resistors R91 or R92 wrong value.            D. Incorrect wiring of MODE switch wafer MS1R.            E. Tube V9A defective.</p>
<p>29. No carrier generator injection signal with MODE switch in either LSB and/or USB position. (TUNE and CW output ok.)</p>	<p>A. Check items 18A through 18D.            B. Red coaxial cable, from point 1 on carrier generator circuit board, shorted.            C. USB crystal Y7, or LSB crystal Y8, improper frequency or defective.            D. Capacitors C80, C81, C82, C85, or C86 wrong value.            E. Resistors R81, R82, or R83 wrong value.            F. Tube V8 defective.</p>
<p>30. No LMO injection signal at cathodes of V3A or V11B.</p>	<p>A. Check items 5A, 5B, and 5C.            B. OSC MODE switch wired incorrectly or not in LMO position.            C. Any one of the following coaxial cables connected at the OSC MODE switch-open or shorted, Blk, blue or yel.            D. LMO tube V17 defective, NOTE: If this tube is defective, replace with tube from the same manufacturer.            E. Defective LMO unit, IMPORTANT: If after making all the above checks it is determined that the LMO unit is faulty, return the complete LMO to the Heath Company for replacement. See Page 10 in the Kit Builders Guide.</p>

SYMPTOMS	POSSIBLE CAUSES
<p>31. LMO frequency does not shift properly with MODE switch in various positions.</p>	<p>A. Check items 2A, 2B, 2C, 5A, 5B, 5C, 28A, 29C, 30D, and 30E.            B. MODE switch wafer MS1R wired incorrectly.            C. Resistors R190, R191, and/or R192 wrong value.            D. 30-lug terminal strip improperly wired or some interconnecting segments left between lugs. Check between lugs 2 and 3, 16 and 17, 16 and 15, and 18 and 19.</p>
<p>32. No heterodyne oscillator injection signal at cathodes of V2 or V12.</p>	<p>A. Check items 5A, 5B, and 5C.            B. One of the crystals Y1, Y2, Y3, or Y4 defective, depending on the band segment in use.            C. Oscillator circuit board installed backwards on chassis.            D. Band switch wafers BS1R, BS2R, or BS3R wired incorrectly.            E. Red coaxial cable from lug 5 of Bandswitch BS3R either open or shorted.            F. Capacitors C70, C73, C77, or C78 wrong value.            G. Tube V7 defective.</p>
<p>33. Relay DE will not energize with MODE switch in TUNE position.</p>	<p>A. Tube V5B defective.            B. Relay coil RL1 defective.            C. Function switch wafer FS1R wired incorrectly. Check blu and red leads at lugs 11 and 12, wht and yel-wht at lugs 7 and 8.            D. MODE switch wafer MS1R wired incorrectly. Check yel-wht and wht leads at lugs 7 and 9.            E. FUNCTION switch in CAL position.</p>

SYMPTOMS	POSSIBLE CAUSES
<p>34. Relay DE will not energize with MODE switch in LSB or USB and Function switch in VOX position.</p>	<ul style="list-style-type: none"> <li>A. Check items 9C, 9D, 9E, 26G through 26M, 33A through 33E.</li> <li>B. VOX sensitivity control improperly adjusted.</li> <li>C. Tube V4B defective.</li> <li>D. Diode SR52 wrong type or installed backwards.</li> <li>E. Zener diode wrong type or defective.</li> <li>F. FUNCTION switch wafer FS1R wired incorrectly. Check grn and grn-wht leads at lugs 3 and 4.</li> <li>G. ATG (anti-trip gain) control set too high.</li> </ul>
<p>35. Relay DE energizes and stays energized regardless of VOX control settings.</p>	<ul style="list-style-type: none"> <li>A. Zener diode wrong type or installed backwards.</li> <li>B. Anti-trip rectifiers SR50 and SR51 installed backwards.</li> <li>C. VOX rectifier SR52 defective.</li> <li>D. Check item 33B.</li> <li>E. B+ supply voltage too high (see warning on Page 109).</li> </ul>
<p>36. Transmitter tends to be unstable.</p>	<ul style="list-style-type: none"> <li>A. Final and/or driver neutralization not proper.</li> <li>B. Driver tuning capacitor mounting hardware not tight.</li> <li>C. Transmitter mixer, and carrier generator circuit board mounting hardware not tight. Lockwashers left out from between the chassis and circuit boards.</li> <li>D. Check items 15D and 15E.</li> <li>E. Defective feedthrough capacitors AP through AU.</li> <li>F. Coils L14, L15, and L16 misaligned.</li> </ul>
<p>37. Receiver has slow recovery from transmit condition. (More predominant in CW mode of operation.)</p>	<ul style="list-style-type: none"> <li>A. MIC CW LEVEL control set too high. (See Page 105 under Operation.)</li> <li>B. Resistor R51, R232, or R233 wrong value.</li> <li>C. Components at the RF GAIN control and AGC switch wired incorrectly.</li> </ul>

SYMPTOMS	POSSIBLE CAUSES
<p>38. Relay DE will not energize with MODE switch in CW position (with key depressed), but operates in all other positions.</p>	<p>A. Check items 34B and 34G.            B. Tube V10A defective.            C. Brn coaxial cable from lug 2 on the MODE switch to point 2 on the carrier generator circuit board open or shorted.            D. Wiring incorrect on front wafer of MODE switch.            E. P.E.C. (#84-22) defective.</p>
<p>39. Anti-Trip Gain (ATG) control has no effect. Transmitter keeps tripping "on" when listening to loud signals.</p>	<p>A. ATG control improperly adjusted.            B. Diode rectifiers SR50 and/or SR51 defective or installed backwards.            C. Resistors R56, R57, or R65 wrong value.            D. Capacitors C47 or C66 wrong value or defective.</p>
<p>40. Automatic Level control (ALC) has very little or no effect on RF output.</p>	<p>A. Diode rectifiers SR150 or SR51 defective or installed backwards.            B. Capacitors C155, C156, C157, or C158 wrong value or defective.            C. Relay DE contact 4 and 5 dirty or open.            D. Grn and brn-wht wires reversed to contacts 6 and 5 of relay DE.            E. MODE switch wired incorrectly. Check brn and blue wires at lugs 19 and 17 of MS2F.            F. 30 lug terminal strip improperly wired or some interconnecting segment left between lugs. Check between lug 10 and 11, lugs 24 and 25, lug 26 and 27.            G. Final and/or driver stage not neutralized.            H. Drive plate coil L16 misadjusted.</p>
<p>41. RF output increases slowly.</p>	<p>A. 30-lug terminal board improperly wired or some interconnecting segment removed from between lugs by mistake. Check between lugs 11 and 12.            B. Check items 40A through 40E.</p>
<p>42. Plate meter reads backwards and ALC meter reads full scale with audio oscillations heard from speaker.</p>	<p>A. Check for a short circuit between contacts 17 and 18 of relay DE. (Receiver circuits still have B+ voltage applied in transmit condition.)</p>



# SPECIFICATIONS

## RECEIVER

Sensitivity. . . . .	0.1 microvolt for 10 db of signal-plus-noise to noise ratio.
Selectivity. . . . .	2.1 kc at 6 db down, 5 kc maximum at 60 db down.
Image Rejection . . . . .	50 db or better.
IF Rejection. . . . .	50 db or better.
Spurious Responses. . . . .	All below 0.1 microvolt equivalent signal input, except at 51.250 mc which is below 0.3 microvolt.
Antenna Input Impedance. . . . .	50 $\Omega$ nominal (unbalanced).
Audio Output Impedance -	
Matching Speaker. . . . .	8 $\Omega$ .
Matching Headphones. . . . .	600 $\Omega$ or higher.
Audio Output Power. . . . .	1 watt.
AGC Characteristics . . . . .	Audio output level varies less than 12 db for 50 db change of input signal level (0.5 $\mu$ v to 150 $\mu$ v).

## TRANSMITTER

DC Power Input -	
SSB . . . . .	180 watts PEP.
CW. . . . .	150 watts.
RF Power Output -	
SSB . . . . .	100 watts PEP (50 $\Omega$ non-reactive load).
CW. . . . .	90 watts (50 $\Omega$ non-reactive load).

Output Impedance. . . . .	50 $\Omega$ nominal with not more than 2:1 SWR.
Carrier Suppression. . . . .	55 db down from rated output.
Unwanted Sideband Suppression. . . . .	55 db down from rated output at 1000 cps and higher.
Distortion Products . . . . .	30 db down from rated PEP output.
Hum And Noise. . . . .	40 db or better below rated carrier.
Audio Input. . . . .	.010 volt minimum for rated output.
RF Compression (ALC). . . . .	10 db or better at 30 microamperes of final amplifier grid current.
CW Sidetone. . . . .	Internally switched to speaker with transmitter in CW Mode and key depressed. Approximately 800 cps tone.
Oscillator Feedthrough or Mixer Products. . . . .	55 db below rated peak output.
Keying Characteristics. . . . .	VOX operated from keyed tone, using grid-block keying.
<b>GENERAL</b>	
Frequency Coverage. . . . .	49.5 to 54.0 mc in 500 kc segments (50.0 to 52.0 mc with crystals supplied).
Frequency Selection . . . . .	Built-in LMO, or crystal control.
Frequency Stability. . . . .	Less than 100 cps drift per hour, after 20 minutes warm-up, under normal ambient conditions. Less than 100 cps drift for $\pm 10\%$ supply voltage variations.
Modes Of Operation -	
SSB. . . . .	Single sideband (suppressed carrier, with selectable upper or lower sideband).
Tune. . . . .	Continuous wave.
CW. . . . .	Keyed continuous wave (800 cps offset crystal for cross-mode operation between USB and CW).

Dial Accuracy -	
Electrical. . . . .	Within 400 cps on all band segments, after calibration at nearest 100 kc point.
Visual. . . . .	Within 200 cps.
Dial Backlash. . . . .	No more than 50 cps.
Calibration. . . . .	Every 100 kc.
Intermediate Frequencies -	
Receiver First IF And Transmitter Second IF. . . . .	8,395 to 8,895 mc passband.
Receiver Second IF And Transmitter First IF. . . . .	3,395 mc center frequency.
Power Requirements -	
High Voltage. . . . .	+700 volts DC at 250 ma with 1% maximum ripple.
Low Voltage. . . . .	+250 volts DC at 100 ma with .05% maximum ripple.
Bias Voltage. . . . .	-115 volts DC at 10 ma with .5% maximum ripple.
Filament Voltage. . . . .	12.6 volts AC/DC at 4.355 amps.
Cabinet Dimensions. . . . .	14-7/8" wide x 6-5/8" high x 13-3/8" deep.
Net Weight. . . . .	17 lbs.
FRONT PANEL CONTROLS . . . . .	
	Main Tuning (LMO).
	Meter.
	AF Gain with noise limiter switch.
	RF Gain with AGC switch.
	Preselector.
	Band.
	Final Tuning.
	Final Loading.
	Driver.
	Mode.
	Function.
	Oscillator Mode.
	Mic/CW Level.

INTERNAL CONTROLS. . . . .

- Bias.
- Crystal Frequency.
- ALC Meter.
- LMO Sideband shift.
- Carrier Balance
- Carrier Null.
- Calibrate Adjust.
- CW Sidetone Level.
- Relative Power Meter.
- S-Meter.
- Headphone Level.
- VOX Gain.
- VOX Delay.
- VOX Anti-Trip Gain.

TUBE COMPLEMENT. . . . .

- 1 - OA2: Voltage regulator.
- 1 - 6BZ6: LMO.
- 1 - 12AT7: USB and LSB carrier generator.
- 4 - 6EA8: Heterodyne oscillator and amplifier, Microphone preamplifier and cathode follower; receiver second mixer and auxiliary crystal oscillator; transmitter first mixer and 100 kc crystal calibrator.
- 3 - 6AZ8: Receiver/transmitter IF amplifier and VOX amplifier; receiver IF amplifier and VOX relay amplifier; transmitter isolation amplifier and CW carrier generator.
- 1 - 6CB6: Transmitter second mixer.
- 1 - 12BY7: Transmitter driver amplifier.
- 2 - 6146: Final amplifiers.
- 1 - 6EB8: Receiver second audio preamplifier and audio power output amplifier.
- 2 - 6DS4: Receiver RF amplifier; receiver first mixer.
- 1 - 2N2712: Receiver first audio amplifier.

TRANSISTOR COMPLEMENT. . . . .

EQUIPMENT USED TO PREPARE SPECIFICATIONS. . . . .

- Heath AG-9A Audio Generator.
- Heath V-7A VTVM.
- Heath MM-1 VOM.
- Heath AW-1 Audio Wattmeter.
- Heath HO-10 Monitor Scope.
- Heath HN-31 "Cantenna" Dummy Load.
- Hewlett Packard 606A Signal Generator.
- Dynascan Corp., 111 Digital Voltmeter.
- Boonton Electronics 91-CA RF Voltmeter.
- Bird Electronics Corp., 43 Thruline Wattmeter.
- Tektronix Inc., 581A Oscilloscope.
- Radio Products Inc., SB-12 Panoramic Panalyzer.
- Hewlett Packard 524B Electronic Counter.

## DIODE COMPLEMENT

Silicon Rectifier. . . . .	6 - 1N2079: VOX rectifier; anti-trip rectifier; ALC rectifier; DC blocking.
Silicon Diode. . . . .	3 - GE S187: Noise limiter; AGC rectifier.
Germanium Diode. . . . .	10- 1N191: Balanced modulator; product detector; AGC rectifier; RF sampling rectifier.
Zener Diode. . . . .	1 - 1N4166A: Voltage regulator (15 V).

## HEATHKIT ACCESSORIES

The following Heathkits are available for use with the SB-110A Transceiver.

ITEM	FUNCTION
HP-23A AC Power Supply. . . . .	Supplies the necessary B+, filament and bias voltages for fixed station operation from a 120 VAC, 50/60 cps source.
HP-13A Transistorized DC Power Supply. . . . .	Supplies the necessary B+, filament and bias voltages for mobile operation from a 12 VDC source.
SBA-100-1 Mobile Mounting Kit. . . . .	Provides easy and simple mounting by plugging the Transceiver into the Mobile Mounting unit. There are no cables or wires to connect or disconnect except the microphone, once the mounting kit is installed.
SB-600 Speaker. . . . .	Matching 8 ohm SB-series speaker for fixed station use.
HS-24 Speaker. . . . .	Matching 8 ohm speaker for mobile or fixed station use.
HDP-21 SSB Microphone . . . . .	Special audio frequency microphone (300 to 3000 cps) that favors voice frequencies for SSB communications. Stand mounted: High impedance output with PTT switch.
GH-12 Handheld Microphone. . . . .	Ideal for mobile operation. High impedance output with PTT switch.
HO-10 Monitor Scope. . . . .	Checks the quality of the output signal by displaying RF envelopes and trapezoidal patterns. Contains a built-in two-tone test oscillator.

HM-15 Reflected Power Meter. . . . .	Indicates the transmission line and antenna match. Shows the forward or reflected power and standing wave ratio.
HD-15 Hybrid Phone Patch. . . . .	Transfers calls from the Transceiver to phone lines and vice versa.
HN-31 "CANTENNA" Transmitter Dummy Load. . . . .	Ideal for testing the transmitter section of the Transceiver. It is a 50 ohm non-reactive load with less than 1.5 V SWR and handles up to 1 kilowatt ICAS power.

---

The Heath Company reserves the right to discontinue instruments and to change specifications at any time without incurring any obligation to incorporate new features in instruments previously sold.

## CIRCUIT DESCRIPTION

The circuit of the Transceiver may be more easily understood if you refer to the Schematic Diagram (fold-out from Page 149) and the Block Diagram (fold-out from Page 126) while reading the Circuit Description. There is also a large Schematic Diagram on the back of the fold-in sheet which contains Figure 3-9. Since the Transceiver uses some complex circuitry, small sections of the Schematic Diagram are also included in this description to make the circuits easier to follow.

Letter-number designations for resistors, capacitors, and diodes are coded by tube stages. For example, the components for stage V1 are numbered 10 through 19; the components for stage V13 are numbered from 130 through 139, and so on throughout the tube stages of the Schematic. The components in transistor stage Q1 are numbered from 210 through 219. The product detector and balanced modulator stages also have their own series of numbers, and the miscellaneous components throughout the Schematic that are not tied to any particular stage are numbered upward from 230.

The switches and controls are identified by the front panel or chassis name. Rotary switches that have more than one wafer have letter-number designations. For example, the designation BS1R means this switch section is part of the Band Switch, the 1st wafer from the knob end of the switch, with lugs on the Rear side of the wafer. The designation MS2F means this is part of the Mode Switch, the 2nd wafer, with lugs on the Front side of the wafer.

Both relays are shown in the receive position on the Schematic Diagram.

Note that the receiver circuits are across the top, and the transmitter circuits across the bottom of the Schematic and Block Diagrams. An upper sideband signal at a frequency of 50,110 megacycles will be used to trace through the Transceiver to show what action the various stages have on this signal. The transmitter stages will be explained first to show how they develop a single sideband signal. The frequency chart shows the various frequencies found throughout the Transceiver.

### TRANSMITTER CIRCUITS

Relay amplifier tube V5B, which controls transmit-receive relay RL1, is held in cutoff in the receive mode by a positive voltage at its cathode. This tube is made to conduct and place the transmitter "on the air" in the following ways: by either the PTT (Push-To-Talk) or the VOX (Voice-Operated-Transmit) method. For PTT operation, the cathode of tube V5B is connected to ground through resistor R236 and the Push-To-Talk switch on the microphone. For VOX operation a positive voltage is applied at the grid that overcomes the cutoff bias at the cathode of V5B.

BAND SEGMENT MC	CARRIER GENERATOR CRYSTAL FILTER (FIXED) KC	LMO (BETWEEN 5 - 5.5) MC	BANDPASS COUPLER (BETWEEN 8.395- 8.895) MC	HETERODYNE OSCILLATOR (CRYSTAL FIXED) MC	2ND TRANSMITTER MIXER-TRANSMITTED SIGNAL MC			
50.0	USB 3393.6	5.1114	8.5050	41.605	50,110			
	LSB 3396.4	5.1086				8.5050	41.605	50,110
	CW 3394.4	5.1114				8.5058	41.605	50,1108

FREQUENCY CHART

When relay amplifier V5B conducts, it applies power to transmit-receive relay RL1, causing all circuits to be switched to the transmit mode of operation. Lugs 11 and 12 of RL1 cause power to be applied to relay RL2, which connects the antenna to the transmitter section of the Transceiver.

During transmit operation, the following receiver stages are turned off by relay RL1, which removes their B+ voltage: RF amplifier V1; first receiver mixer V2; second receiver mixer V3A; and second IF amplifier V5A. First audio preamplifier stage Q1 is left in operation, but the following stage, second audio preamplifier V6A, is biased to cutoff by relay RL1, which disconnects its grid from ground. This action disables both of these stages.

First IF amplifier V4A and audio output amplifier V6B operate for both receive and transmit operations.

### Microphone Amplifier And CW Tone Oscillator (Figure 2-1)

The audio signal from the Microphone socket is coupled to Mode switch wafer MS1F. In the LSB and USB switch positions, the signal is coupled through the switch, and through capacitor C100 and RFC2 to the grid of microphone amplifier V10A. The frequency response of this amplifier stage is limited on the low end by capacitor C100, and on the high end by capacitor C101, RFC2 and capacitor C101 prevent any RF signals that may be picked up by the microphone, from appearing at the grid of V10A.

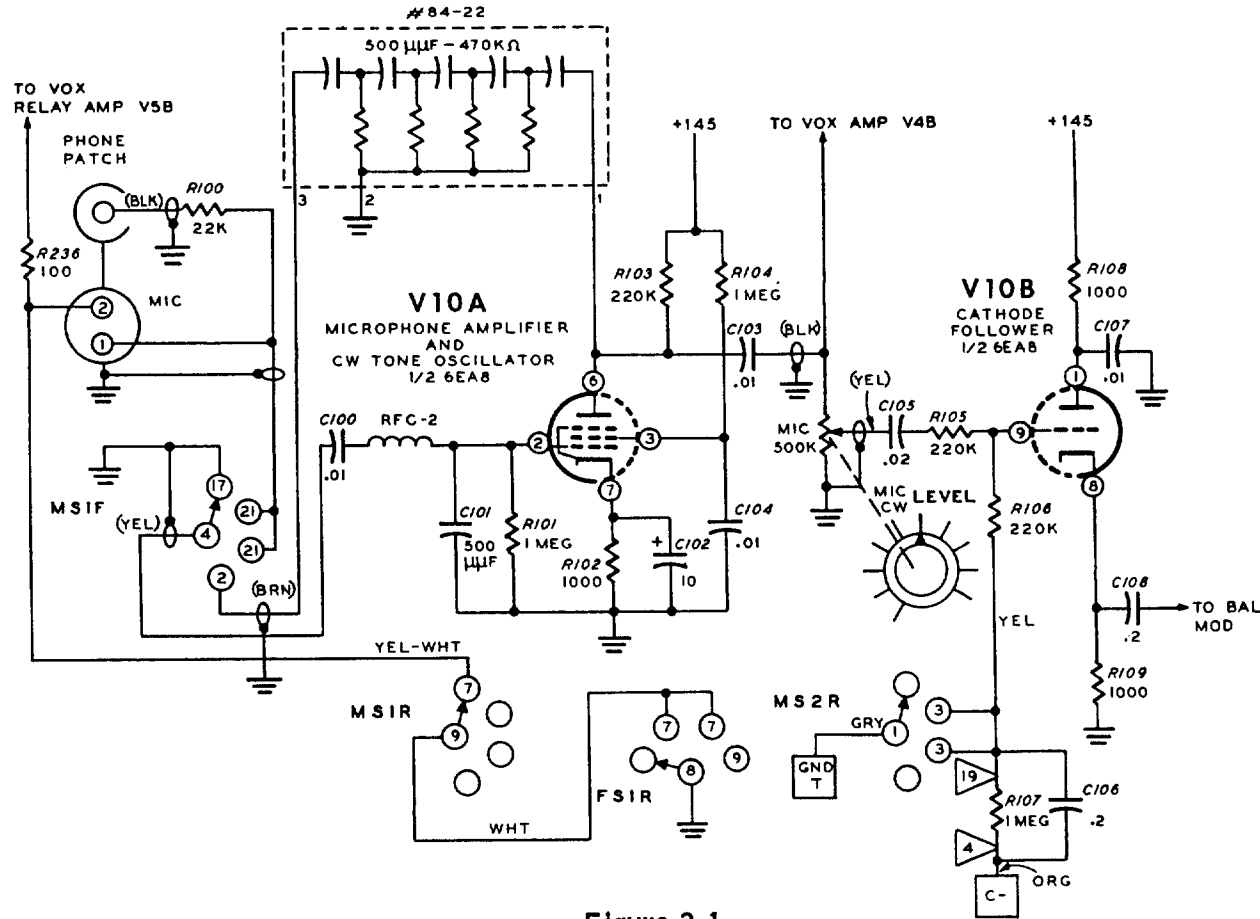

Figure 2-1



The amplified microphone signal from V10A is coupled through capacitor C103 and the Microphone Level control to cathode follower V10B. V10B which couples the signal to the low impedance input circuit of the balanced modulator stage, is disabled by Mode switch wafer MS2R for CW and Tune operation.

When the Mode switch is in the CW position, the phase shift network (P.E.C.) is connected between the plate and grid of V10A, causing it to function as a 800 cps phase-shift oscillator. CW operation of the Transceiver will be explained later.

### VOX Amplifier And Relay Amplifier (Figures 2-2 and 2-3)

When the Function switch is in the VOX position, the transmitter is turned on and off in the following manner by the amplified microphone signal. The signal from V10A is coupled through the VOX control and capacitor C45 to the grid of VOX amplifier V4B. The amplified signal from the plate of V4B is coupled through capacitor C46 to diode SR52. SR52 rectifies the signal and the positive DC pulses that result are filtered by capacitor C59. Thus, only a DC voltage is coupled to relay amplifier V5B.

Relay amplifier V5B is held in a cutoff state by a Zener diode-controlled positive voltage at its cathode. When the positive voltage from V4B appears at the grid, it causes V5B to conduct and places transmit-receive relay RL1 in the transmit position.

The length of time that V5B conducts (and holds the transmitter on the air) after the voice signal stops coming from V4B is determined by the VOX Delay control. This control, along with resistor R58, controls the discharge time of capacitor C59. When capacitor C59 discharges more slowly through a larger resistance, the positive voltage remains on the grid of V5B for a longer period of time, and relay RL1 remains in the transmit position.

When the Function switch is in the PTT position, the C- bias voltage is connected to the grid of V4B. This places the tube in a cutoff condition for the USB and LSB settings of the Mode switch, and no audio (VOX) signal can pass through this tube to trigger relay amplifier V5B.

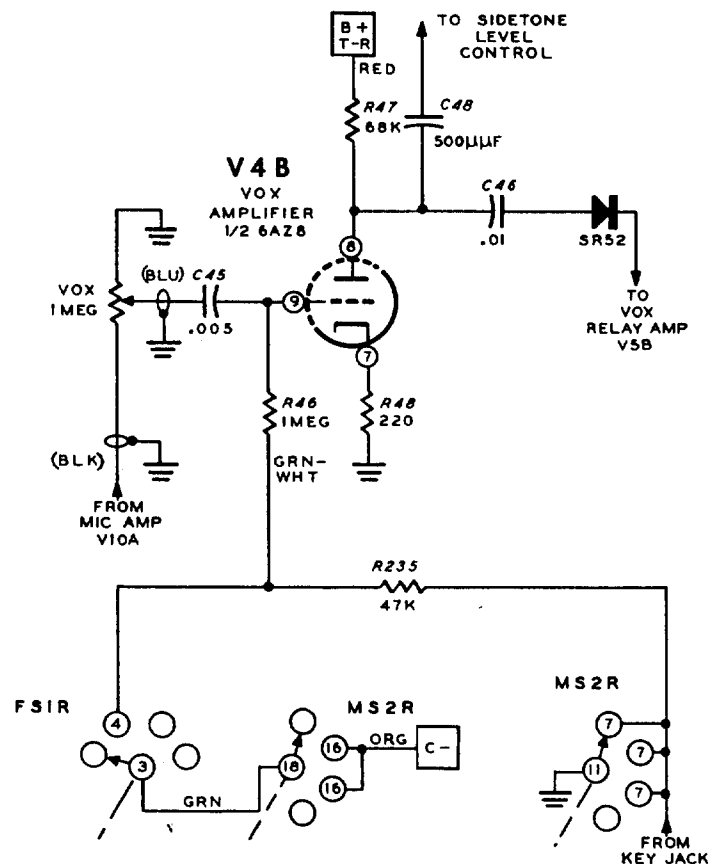

Figure 2-2

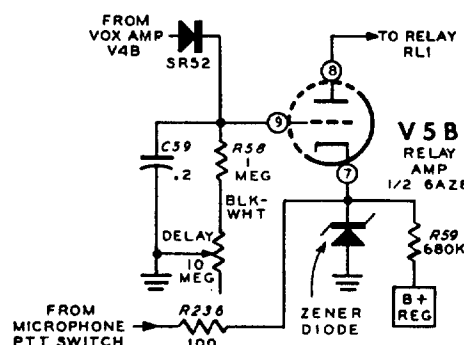

Figure 2-3

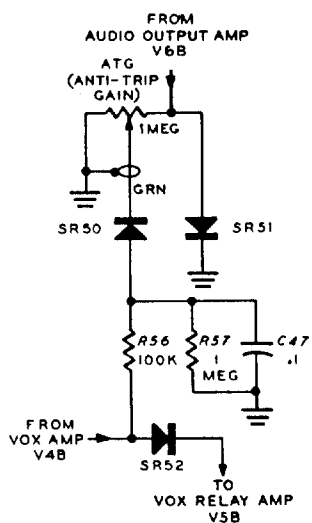

Figure 2-4

### Anti-VOX Circuit (Figure 2-4)

The anti-VOX circuit is used in the receive mode of operation to keep the speaker signals from activating the VOX circuit. An audio signal from the plate of audio output amplifier V6B is coupled through the ATG (Anti-Trip-Gain) control to diodes SR50 and SR51, where the signal is rectified. The negative voltage pulses are filtered by capacitor C47 and resistor R57. The resulting negative DC voltage is applied through resistor R56 to the input side of diode SR52. This biases SR52 so it will not conduct. As a result, the speaker signals that appear at the microphone can not reach relay amplifier V5B, and relay RL1 will not close.

### Carrier Generator (Figure 2-5)

Tubes V8A and V8B are used in Colpitts oscillator circuits that furnish carrier signals to the balanced modulator circuit. V8A serves as the USB (upper sideband) carrier generator, and V8B serves as the LSB (lower sideband) carrier generator. The output of V9A, the CW carrier gen-

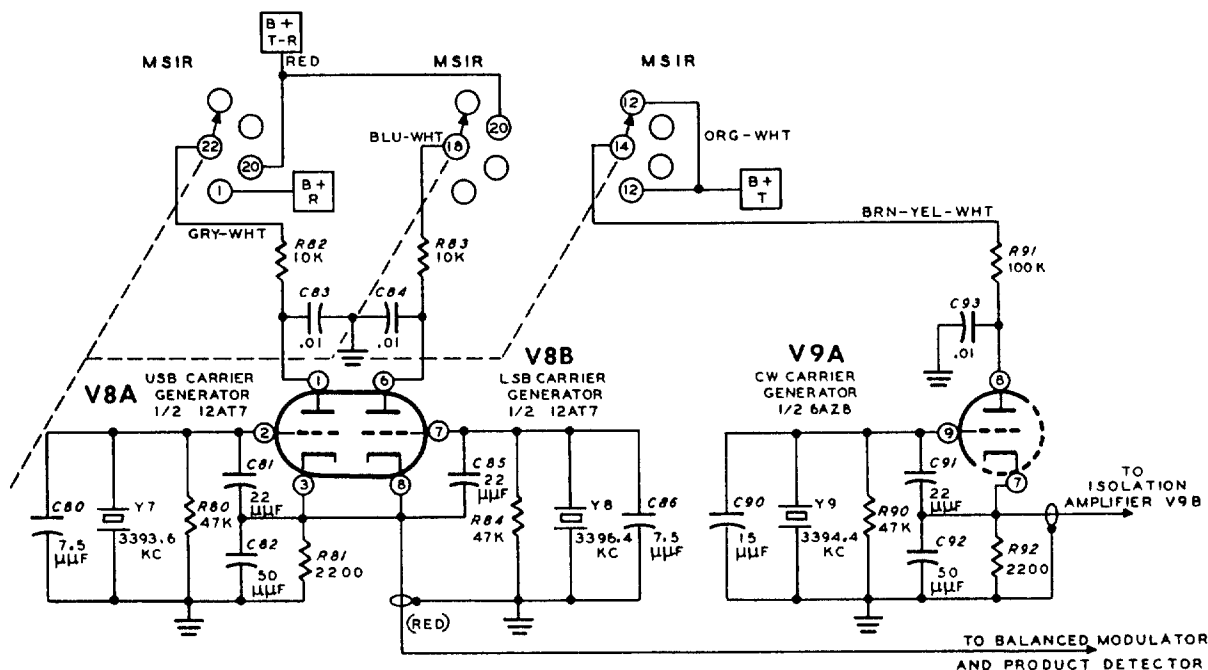

Figure 2-5

erator, is coupled to the grid of isolation amplifier V9B. The correct carrier generator is placed into operation by Mode switch wafer MS1R, which controls the B+ supply voltage to the plates of these tubes.

Note that the frequency of the CW carrier oscillator is 800 cps higher (3394.4 kc) than the frequency of the USB carrier oscillator (3393.6 kc). The reason for this frequency difference is explained in the following paragraph.

For transceive operation in the CW mode, the receiver must be tuned 800 cps below the frequency of the received CW signal. This causes an 800 cps beat note to be produced in the receiver. (If the transmitter and receiver were tuned to the same frequency, as in normal transceive operation, no beat note would be produced.) The transmitter CW carrier generator automatically compensates for this 800 cps difference, and transmits a signal that is 800 cps above the receiver dial setting. This allows the transmitted and received signals to be on the same frequency, yet allowing the receiver to produce an audible tone.

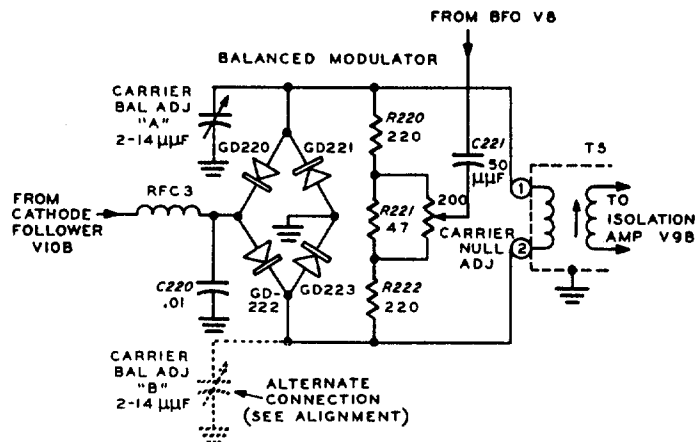

Figure 2-6

### Balanced Modulator (Figure 2-6)

Diodes GD220 through GD223 are connected in a ring-type balanced modulator circuit. When the audio signal from V10B, and the RF signal from carrier generator V8A or V8B are applied to this balanced modulator, two additional frequencies are produced. One is equal to the sum of the audio and carrier frequencies; and the other is equal to the difference between the audio and carrier frequencies. These sum and difference signals are the upper and lower sidebands.

Only the upper and lower sideband signals appear at the output of this circuit. The carrier signal, which is applied across the modulator diode ring, one winding of the balanced modulator transformer T5, resistors R220 through R222, and the Carrier Null Adjust control, is balanced out by the Carrier Null Adjust control and the Carrier Balance Adjust capacitor. Neither the audio or carrier signal appears at the output of the balanced modulator, but the effect of the audio signal unbalancing the nulled circuit at an audio rate produces the sum and difference frequencies called sidebands. With no audio input signal, there is no output from the balanced modulator.

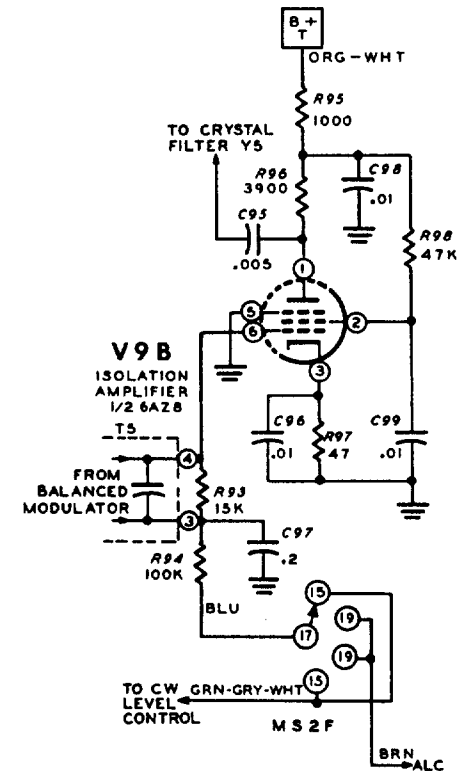

Figure 2-7

### Isolation Amplifier (Figure 2-7)

Both sideband signals are coupled through transformer T5 to the grid of isolation amplifier V9B. Tube V9B amplifies the sideband signals, and also isolates the balanced modulator from crystal filter Y5, to provide proper impedance matching to the crystal filter. The gain of V9B is varied by the ALC (automatic level control) voltage that is applied to its grid through resistors R93 and R94, and through wafer MS2F of the Mode switch (in USB and LSB positions). The complete ALC circuit will be described later.

The output of V9B is coupled through capacitor C95 to crystal filter Y5. During receive periods, V9B is biased sufficiently to cut the tube off and prevent any signal feedthrough.

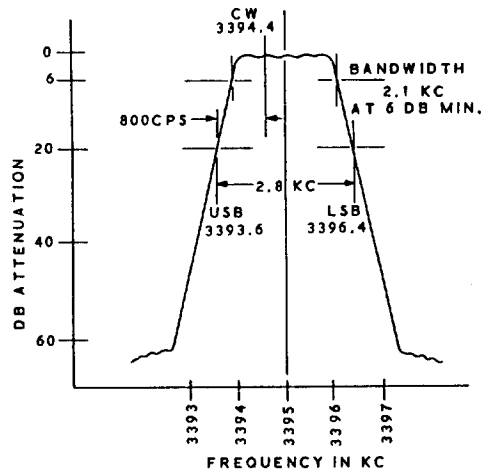

Figure 2-8

### Crystal Filter (Figure 2-8)

Crystal filter Y5 has a center frequency of 3395 kc and a usable bandwidth of 2.1 kc (3393.95 kc to 3396.05 kc at the 6 db points). This filter in the USB mode of operation, passes only the sum frequencies (the sum of the 3393.6 kc carrier generator frequency plus all audio frequencies from 350 cps to 2450 cps); this contains the upper sideband intelligence. The carrier frequency, itself, as shown in Figure 2-8, is further reduced 20 db by the crystal filter. This attenuation plus that of the balanced modulator give an ultimate carrier attenuation of at least 55 db.

In the LSB Mode, the filter passes only the difference frequencies (the 3396.4 kc carrier generator frequency minus all audio frequencies from 350 to 2450 cps); this contains the lower sideband intelligence.

In the CW Mode, a carrier of 3394.4 kc passes through the crystal filter with no attenuation.

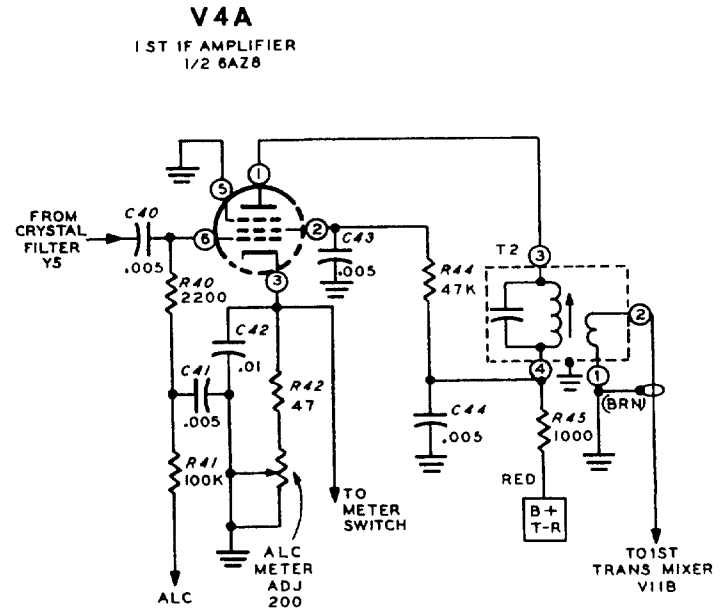

Figure 2-9

### First IF Amplifier (Figure 2-9)

The 3393.6 kc (USB) signal from the crystal filter is coupled through capacitor C40 to first IF amplifier V4A and is amplified. From V4A, the signal is coupled through IF transformer T2 to the grid of the first transmitter mixer, V11B.

### LMO/Xtal Oscillator

Precise oscillator frequencies between 5 and 5.5 mc are needed at the first transmitter mixer stage to obtain the proper output frequencies. These frequencies are supplied through the Osc Mode switch from either the LMO (linear master oscillator) or crystal oscillator.

The LMO, which consists of tube V17 and its associated circuitry, is a very stable linear oscillator that operates over a frequency range of 5 to 5.5 mc. The output of the LMO is coupled through the Oscillator Mode switch (in the LMO position) and capacitor C116 to the cathode of first transmitter mixer V11B.

Because the LMO changes the frequencies in the first transmitter mixer (and second receiver mixer) changing the frequency of the LMO changes the Transceiver operating frequency. For suppressed carrier frequency in both USB and LSB to be centered at the same frequency in the RF spectrum, it is necessary when changing from one of these modes to the other, to shift the frequency of the Transceiver 2.8 kc (see Figure 2-8). This frequency shift is accomplished internally in the LMO and is controlled by the Mode switch. In this manner, the frequency of the suppressed carrier in either mode is the same as the output frequency.

Crystal oscillator V3B may be switched into the circuit by the Osc Mode switch in place of the LMO for crystal-controlled operation of the Transceiver.

### First Transmitter Mixer (Figure 2-10)

The 3393.6 kc IF signal at the grid and an LMO signal of 5.114 mc (see Frequency Chart) at the cathode are mixed in first transmitter mixer tube V11B to produce sum and difference frequencies. The 8.5050 mc output sideband signal from V11B is then coupled through bandpass coupler T6 to the grid of second transmitter mixer V12.

The bandpass coupler is tuned to pass only signals with a frequency

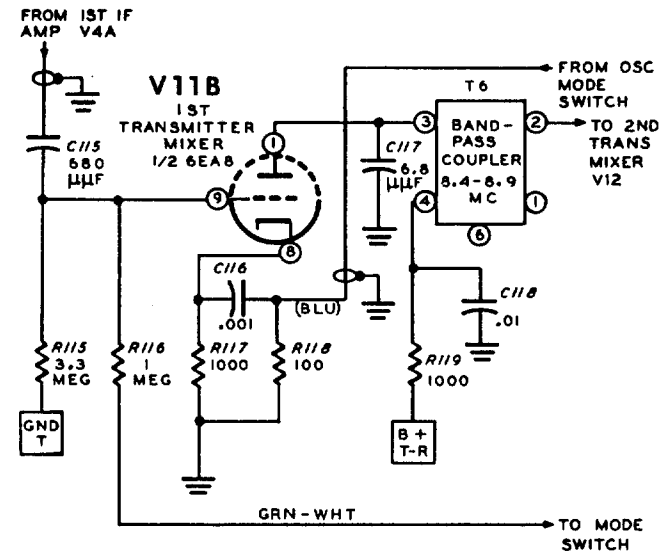

Figure 2-10

between 8.395 and 8.895 mc. Only the sum of the carrier generator and LMO signal frequencies fall within this frequency range. In all cases, it is only the sum of the frequencies from V11B that is passed through the crystal filter; the difference frequencies always fall outside its frequency range.

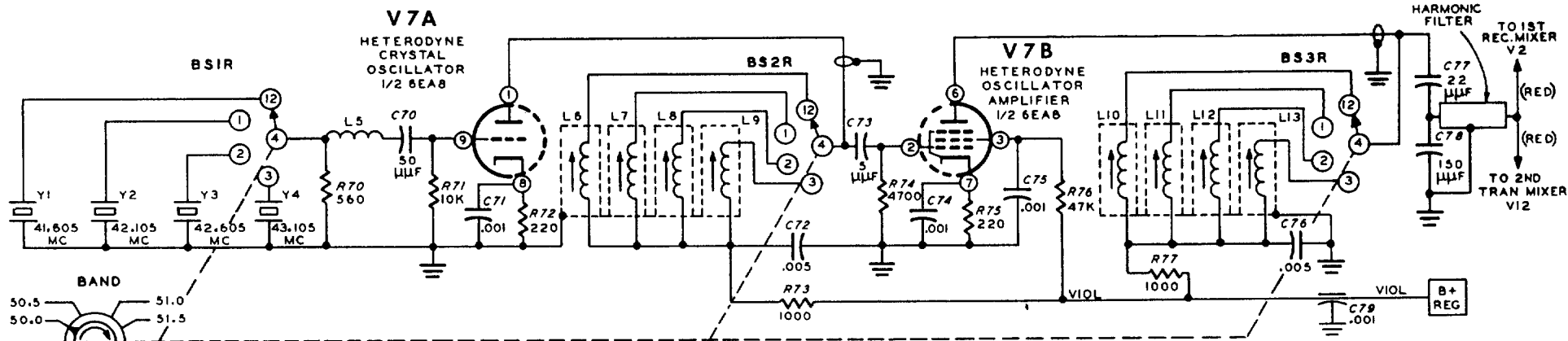

Figure 2-11

### Heterodyne Crystal Oscillator And Amplifier (Figure 2-11)

A precise oscillator frequency of 41,605 mc is needed at the second transmitter mixer stage to obtain the proper 50,110 mc output frequency. This 41,605 mc signal originates at the heterodyne crystal oscillator circuit of tube V7A. Band switch wafer BS1R selects the proper crystal for the grid circuit of this stage, and wafer BS2R selects the proper plate coil.

The oscillator signal from V7A is coupled through capacitor C73 to the grid of heterodyne oscillator amplifier V7B. Band switch wafer BS3R selects the proper coil for the plate circuit of V7B. The output signal from V7B is coupled through capacitor C77 to a half-wave harmonic filter which has high attenuation to any harmonic content that may be present. The signal is then fed to the cathode of second transmitter mixer V12.

### Second Transmitter Mixer (Figure 2-12)

The 8,5050 mc bandpass coupler output signal at the grid of second transmitter mixer V12 is mixed with the 41,605 mc heterodyne oscillator signal at the cathode to produce sum and difference frequencies. The plate of V12 is tuned by L14 and variable capacitor C125A to pass only those frequencies between 50 and 54 mc. All other frequencies are bypassed to ground through C127.

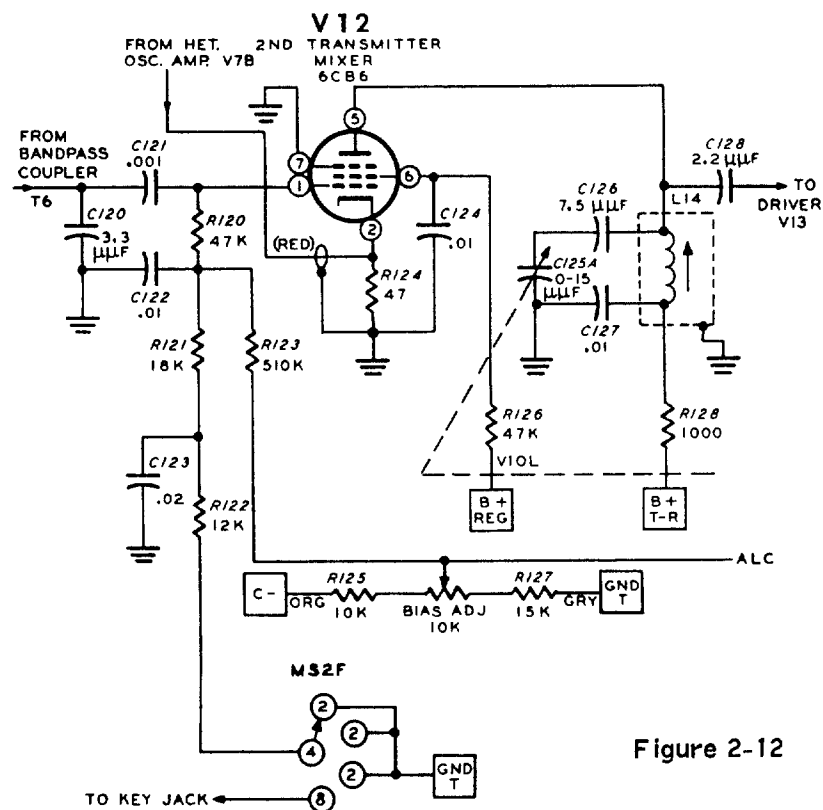

Figure 2-12

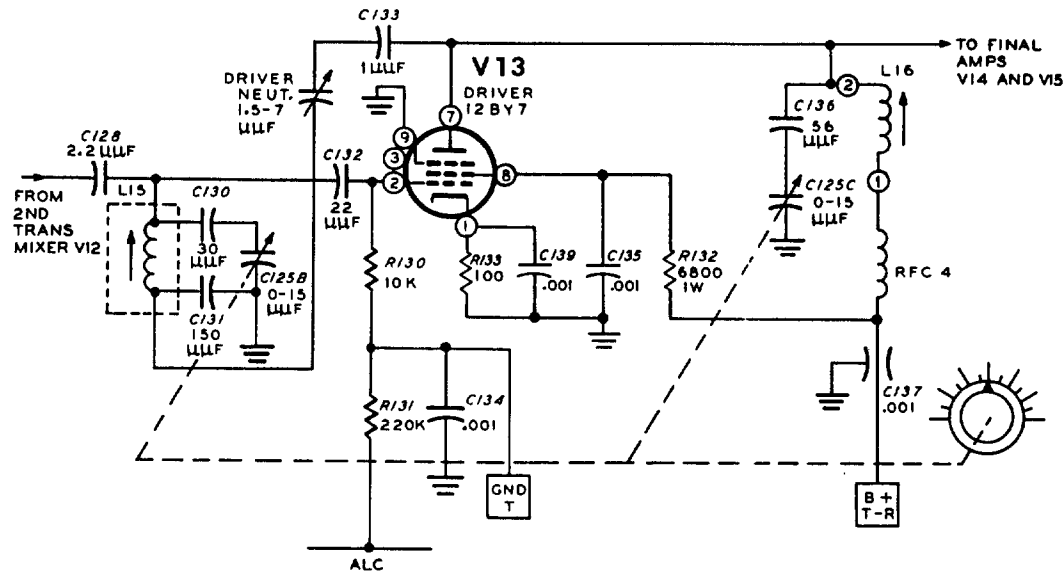

Figure 2-13

### Driver (Figure 2-13)

Driver stage V13 functions as a voltage amplifier. This stage increases the signal to a level sufficient to drive the final amplifiers. Since the grid and plate circuits are tuned to the same frequency, the tube socket is shielded to prevent self-oscillation.

The grid of V13 is tuned to the desired frequency by coil L15 and variable

capacitor C125B, another section of the driver tuning capacitor. Coil L16 and capacitor C125C, the last section of the driver tuning capacitor, tune the plate circuit of V13.

Neutralization of V13 is accomplished by feeding a portion of the plate signal back to the grid through the Driver Neutralizing capacitor and coil L15.

## Final Amplifiers (Figure 2-14)

From driver V13, the signal is coupled to the grids of final amplifiers V14 and V15, which are connected in parallel and function as Class AB<sub>1</sub> linear amplifiers. RF driving voltage is developed across RFC5.

The plate voltage is shunt fed through RFC6. Zero signal plate current is limited to 50 ma in transmit conditions. Neutralizing is accomplished by feeding a portion of the plate signal back to the grids of V14 and V15 through the Final Neutralizing capacitor and coil L16.

The output of V14 and V15 is coupled through capacitor C144 to the pi-section plate tank circuit. The plate tank resonance is tuned by the Final Tuning capacitor. The Final Loading capacitor provides a 50  $\Omega$  impedance point and permits matching to reactive loads up to a 2.1 SWR. The output is coupled through antenna relay RL2 to the RF Out connector. RFC7 is a DC protection device in case of failure of C144.

## CW Operation

For CW operation, tube V10A operates as an 800 cps phase-shift oscillator. This 800 cps tone is coupled to the receiver audio circuits so an operator can hear his keying during transmission; it is also used to key the transmitter on by means of the VOX circuit.

The Mode switch, in the CW position, causes the following circuit changes to occur: cutoff bias is applied to the grids of cathode follower V10B and VOX amplifier V4B; the CW Level control is connected into the grid circuit of isolation amplifier V9B; and the key is connected into the bias line.

When the key is pressed, cutoff bias (-115 V) is removed from VOX amplifier V4B, as well as from first transmitter mixer V11B and second transmitter mixer V12, allowing these stages to conduct. When V4B conducts, the amplified 800 cps tone is coupled through capacitor C48 and the Side Tone Level control to audio output amplifier V6B. Tube V6B amplifies the tone and couples it to the speaker or headphone.

The tone signal from V4B is also applied through diode SR52 to relay amplifier V5B, where it causes relay RL1 to be placed in the transmit position in the manner described previously.

The output signal from CW carrier oscillator V9A is coupled through capacitor C94 to the grid of isolation amplifier V9B. From V9B, the signal proceeds through the rest of the transmitter in the same manner as the LSB and USB signals.

## Automatic Level Control (ALC)

ALC voltage is obtained by rectifying and filtering part of the RF signal in the grid circuit of the final amplifiers. The resulting -DC voltage is applied as bias to the grids of isolation amplifier V9B and first IF amplifier V4A. The ALC action adjusts the gain of these tubes so they will not overdrive the final amplifiers.

ALC voltage is developed in the following manner: When the final amplifiers begin to draw current, this current flows through resistor R152 and causes a voltage to be developed across it. This voltage which follows the audio voltage peaks, is coupled through capacitor C155 to silicon rectifiers SR150 and SR151. The voltage is rectified by these diodes and then appears as a bias voltage across resistors R153 and R154. These two resistors, and capacitors C157 and C158, are connected in a fast-attack, slow-decay RC filter network which prevents overdrive in all but the extreme settings of the Mic/CW Level control.



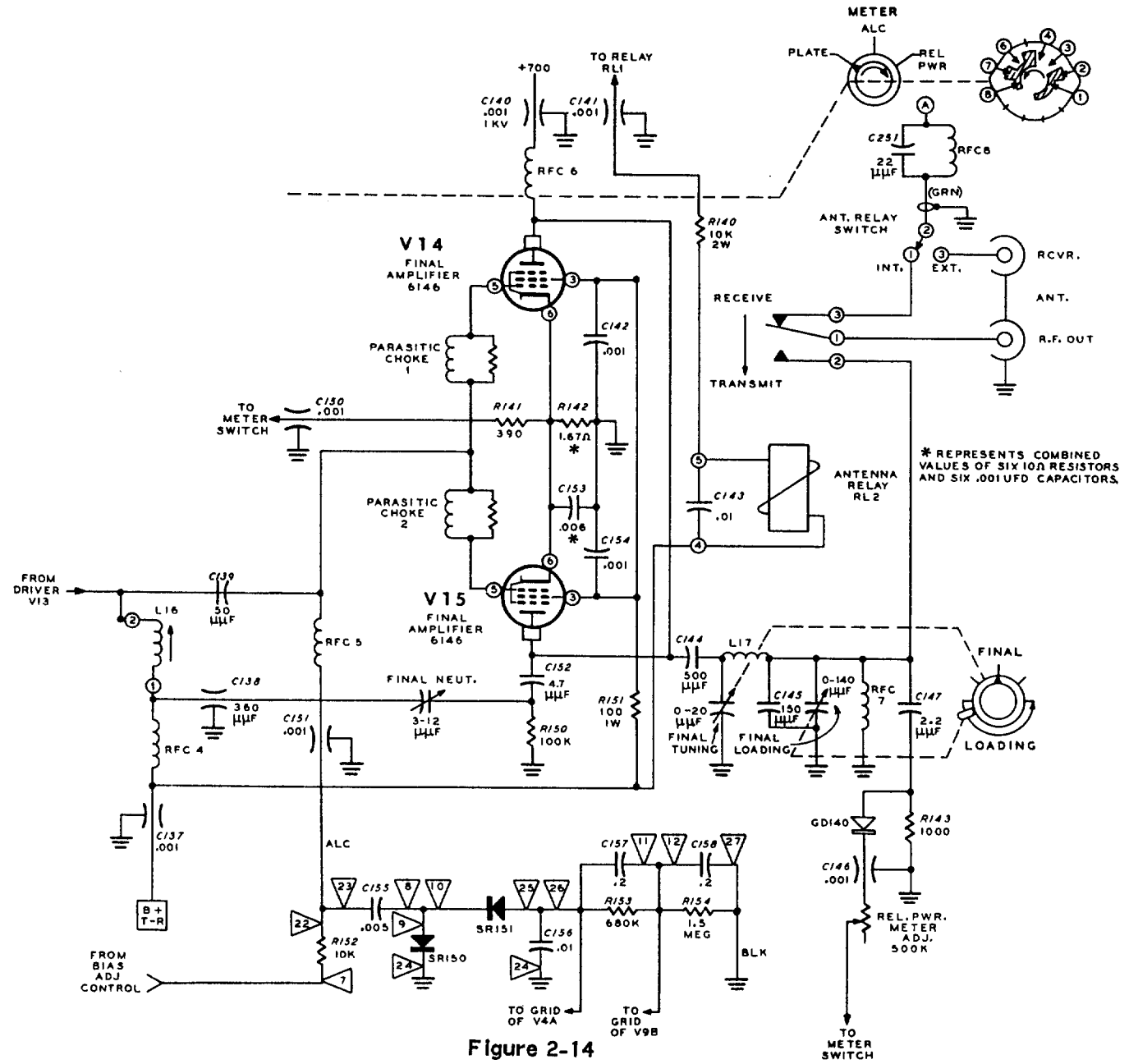

Figure 2-14

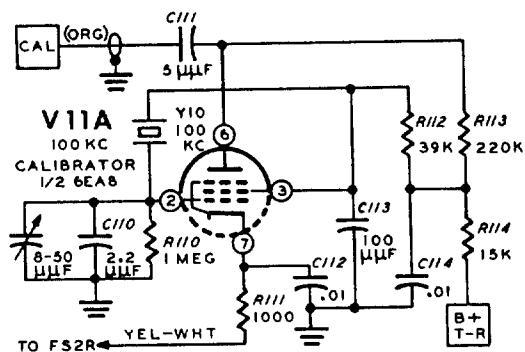

Figure 2-15

### Crystal Calibrator (Figure 2-15)

Placing the Function switch in the Calibrate position completes the cathode circuit of crystal calibrator V11A. In V11A, a 100 kc crystal is connected in a Pierce oscillator circuit, where the oscillator signal is amplified by electron coupling within the same tube. From the plate of V11A this 100 kc signal is coupled to the antenna input of the receiver through capacitors C111 and C10. The 500th through the 540th harmonics of this 100 kc signal are used for calibration checks on the 6-meter band.

With the Function switch in the Calibrate position, B+ voltage is removed from VOX relay amplifier V5B to avoid accidental energizing of the transmitter section when using the crystal calibrator.

### RECEIVER CIRCUITS

Cut off bias is applied to the grids of the following transmitter stages during receiver operation: first transmitter mixer V11B; second transmitter mixer V12; driver V13; and final amplifiers V14 and V15. This bias is removed by relay RL1 during transmitter operation.

### Antenna

The input signal is usually received on a common antenna that is used for both transmitting and receiving. This antenna, which would be connected to the RF Out socket, would be switched between the transmitter and receiver circuits by internal antenna relay RL2.

From relay RL2, the input signal is coupled to the Antenna Relay switch. This switch makes it possible for the Transceiver to be used either with an external antenna relay (Ext position) or with antenna relay RL2 (Int position). An external antenna relay would be used with a linear amplifier that has no provision for internal antenna switching. See Figure 2-16.

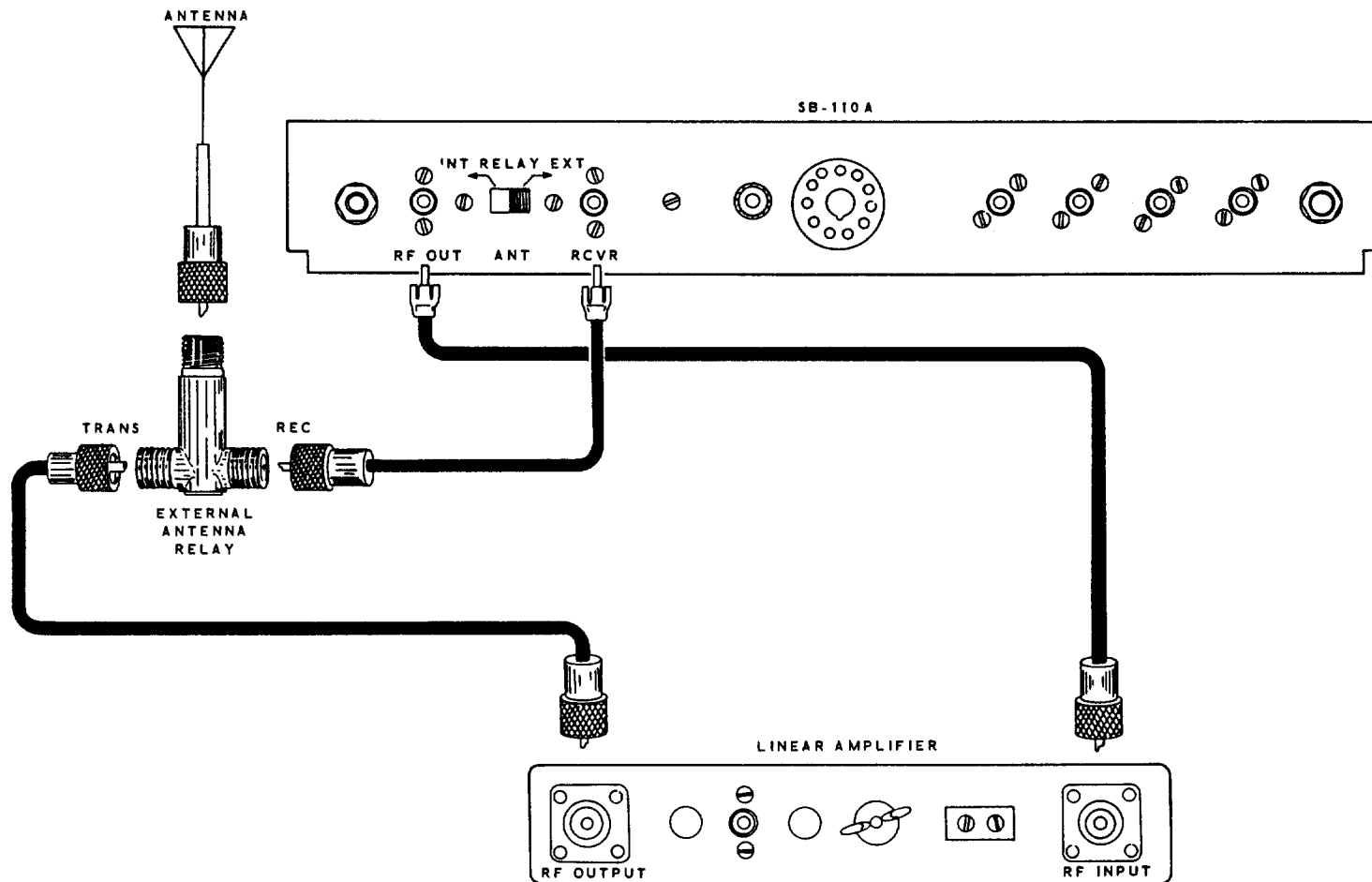

Figure 2-16

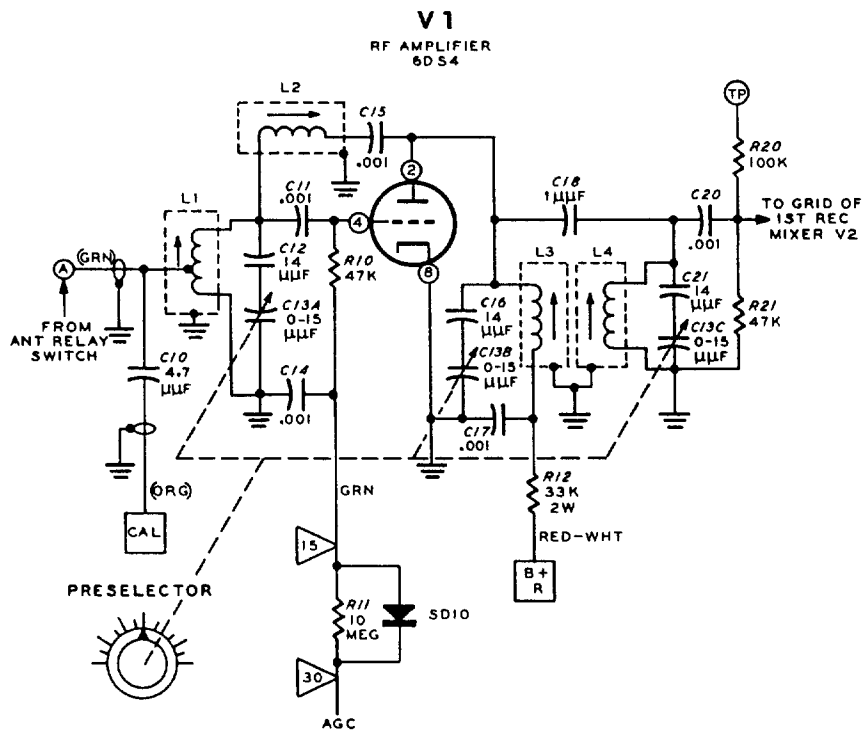

Figure 2-17

### RF Amplifier (Figure 2-17)

The 50,110 mc received signal is coupled from the Antenna Relay switch to input coil L1 through a resonant trap consisting of choke RFC8 and capacitor C251. This trap rejects signals in the 8.4 to 8.9 mc range; thus it offers a high degree of signal rejection at these IF frequencies. Coil L1 serves as an antenna coil to provide impedance matching between the antenna and the grid of RF amplifier V1. This coil is tuned by capacitor C13A for maximum signal coupling to the grid of V1 at all frequencies between 50 and 54 mc.

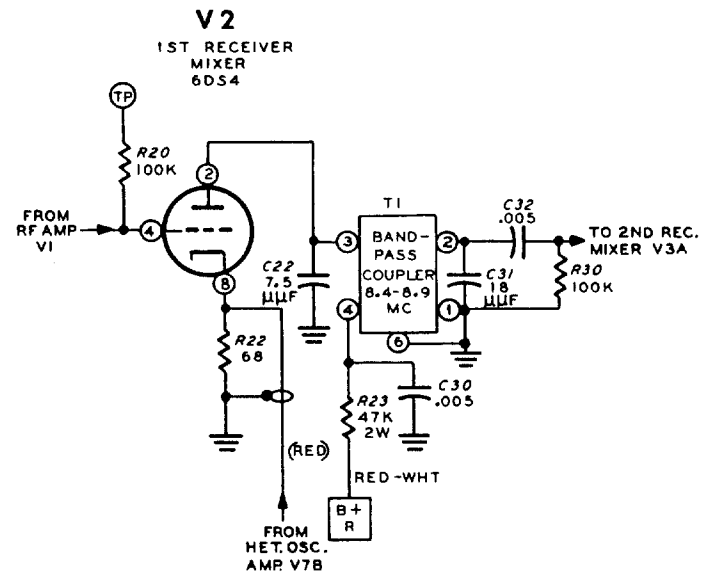

Figure 2-18

The amplified signal from the plate of V1 is coupled through capacitors C18 and C20 to the grid of first receiver mixer V2. Coil L2 and capacitor C15 act as a neutralizing network to cancel any signal energy that might tend to couple internally from the plate to the grid of RF amplifier V1.

The three-section Preselector tuning capacitor tunes the grid and plate circuits of V1, and the grid circuit of V2, to the received signal to provide selectivity in the front end of the receiver. Preselector capacitor C13A, capacitor C12, and coil L1 make up the tuned circuit for the grid of V1. Capacitor C13B, a portion of the Preselector, along with capacitor C14 and coil L3, tune the plate of V1. Capacitor C13C, along with capacitor C21 and coil L4, make up the grid tuning circuit of first receiver mixer V2. Coils L3 and L4 are tuned to limit the band-pass to approximately 500 kc to provide good selectivity in the front end of the receiver.

### First Receiver Mixer (Figure 2-18)

The 50,110 mc received signal at the grid and a 41,605 mc heterodyne oscillator signal at the cathode are mixed in first receiver mixer V2 to produce sum and difference frequencies of 91,715 mc and 8,505 mc. Bandpass coupler T1, in the plate circuit of V2, is designed to pass only those frequencies between 8,395 mc and 8,895 mc. Thus only the 8,505 mc difference frequency is passed on to the second receiver mixer.

### Second Receiver Mixer (Figure 2-19)

The 8,505 mc signal from bandpass coupler T1 is coupled through capacitor C32 to the grid of second receiver mixer V3A. A 5,110 mc signal is coupled to the cathode of V3A from the tunable LMO. These two signals are mixed in V3A, and the 3,395 mc difference frequency is then coupled through crystal filter FL1 to the IF amplifiers.

NOTE: Changing the frequency of the LMO changes the frequency of the Transceiver. See the LMO description on Page 132. The frequency at which the LMO operates is always equal to the difference between the output frequency from passband filter T1 and the 3,395 mc IF frequency.

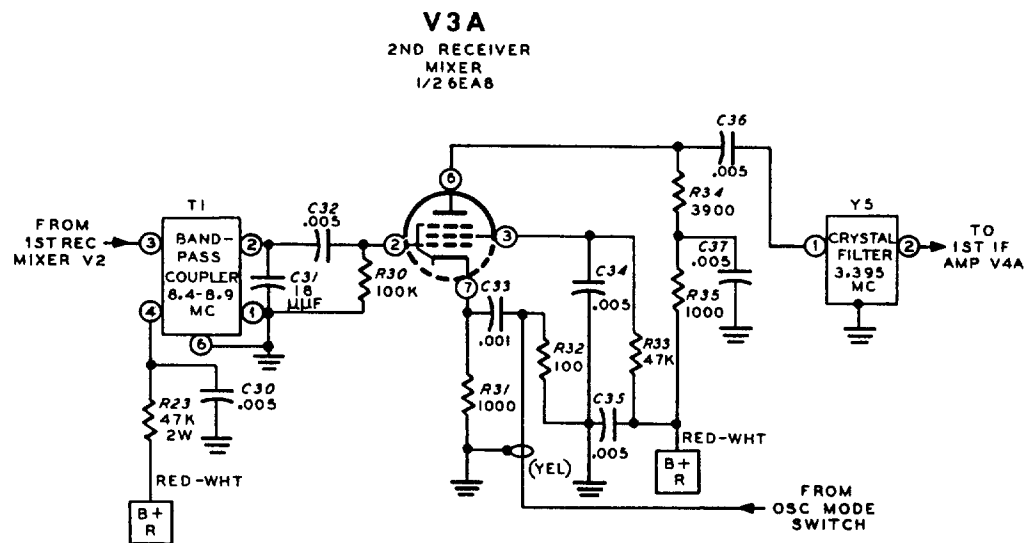

Figure 2-19

## IF Amplifiers (Figures 2-20 and 2-21)

The 3.395 mc signal is coupled through capacitor C40 from the crystal filter to first IF amplifier V4A. The signal is amplified in V4A and then coupled through capacitor C50 to second IF amplifier V5A. From the plate of V5A, the signal is coupled through transformer T3 to the product detector stage.

The S-meter circuitry, which is connected in the IF circuits to indicate received signal strength, will be explained later in a separate section titled "Metering Circuits."

### Noise Limiter (Figure 2-21)

The noise limiter circuit, which consists of silicon diodes SD50 and SD51 and capacitors C54 and C55, is a full-wave, shunt-type diode limiter. The limiter is self-biased and automatically adjusts itself to the degree of modulation of the received signal.

The advantage of this self-biasing type of limiter is that as the signal level moves up or down, the point at which it starts to limit also moves up or down. The Noise Limiter switch is located at the AF Gain control. The control knob is pulled out to turn the limiter on.

### AGC Circuit (Figure 2-21)

The negative bias at the control grids determines the amount of amplification that will be obtained from RF amplifier V1 and IF amplifiers V4A and V5A. The bias for these stages comes from the following two sources, which are connected in parallel; from the negative voltage at the arm of the RF Gain control, and from the AGC (Automatic Gain control) voltage.

The negative bias voltage from the RF Gain control is coupled through resistor R233 to the AGC line. From the AGC line, this voltage is distributed as follows: through resistor R50 to the grid of IF amplifier V5A; through resistors R11 and R10 to the grid of RF amplifier V1; and through RL1 relay contacts 5 and 6, and resistors R41 and R40 to the grid of IF amplifier V4A.

V4A  
1ST IF AMPLIFIER  
1/2 6AZ8

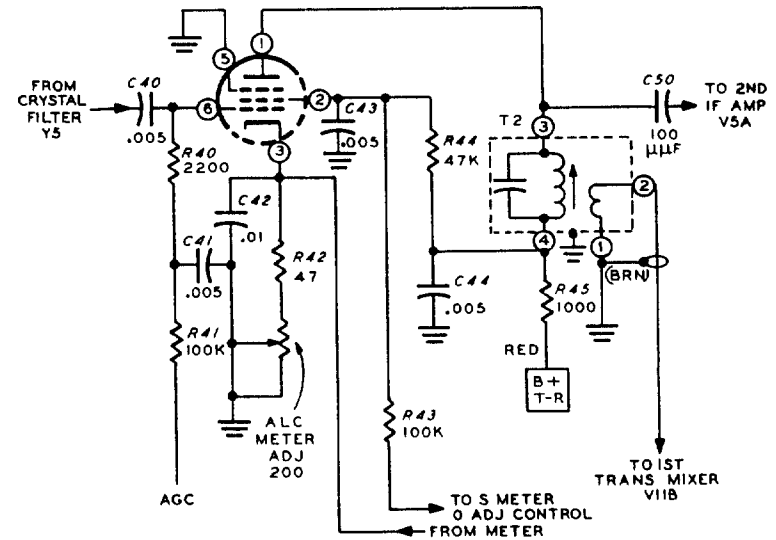

Figure 2-20

The AGC voltage is developed by coupling a portion of the IF output signal through capacitor C56 to AGC diodes SD52 and GD50. These diodes produce a negative DC voltage across resistor R233 and the RF Gain control that is proportional to the signal strength.

A signal that produces an AGC voltage that is higher than the -DC voltage from the RF Gain control, increases the bias at the RF and IF amplifiers, causing their gain to be reduced. This keeps the output from these stages at a nearly constant level despite changes in input signal strength.

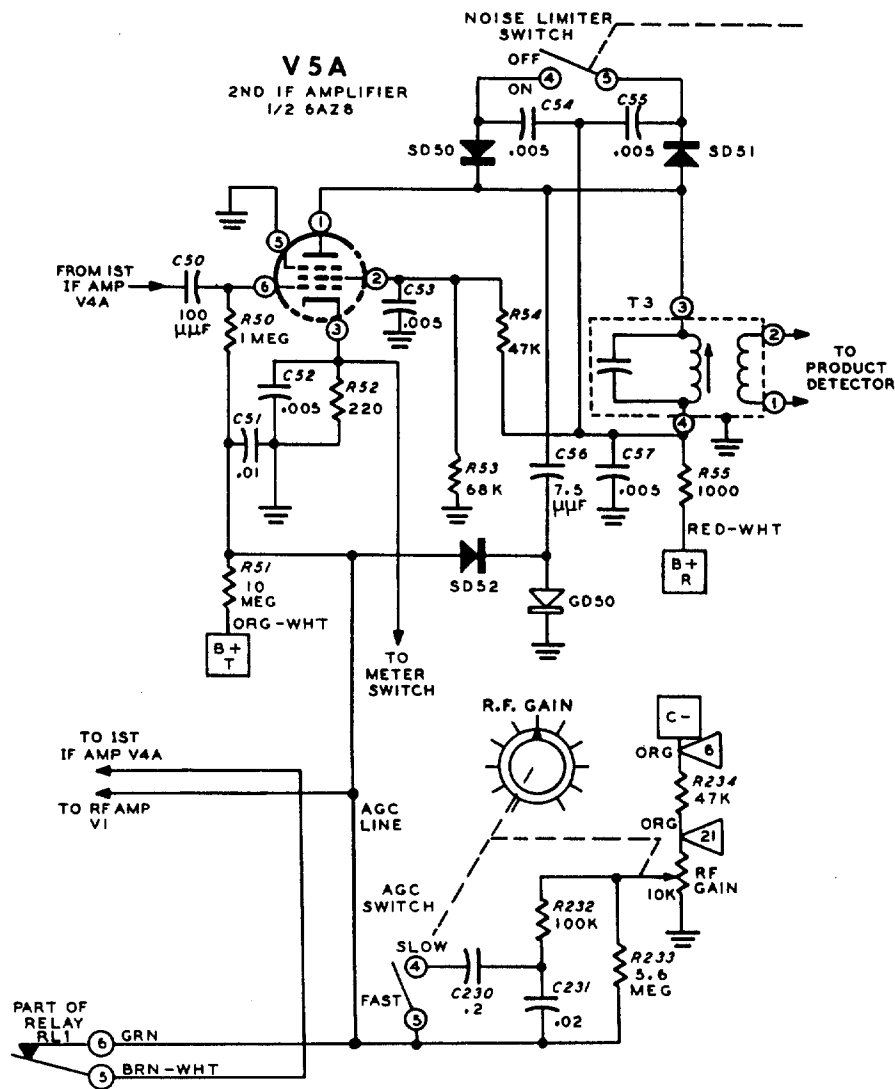

Figure 2-21

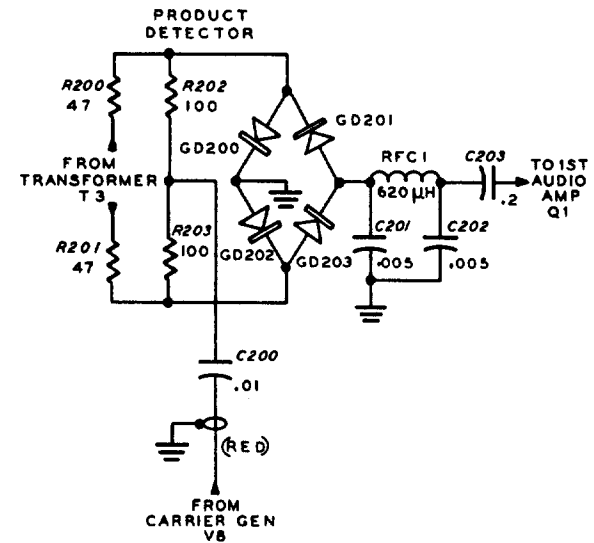

Figure 2-22

The AGC action is instantaneous; however, the length of time it remains in control is determined by capacitors C230 and C231 along with resistors R232 and R233. These capacitors are charged by the AGC voltage when a stronger than normal signal is received, C231 has a fast rate of discharge, and C230 a slow rate of discharge. The capacitors discharge through resistor R233 and the RF Gain control. Because capacitor C231 is ten times smaller than C230, it will discharge ten times faster. The fast and slow AGC selection is made by the push-pull switch located on the RF Gain control.

#### Product Detector (Figure 2-22)

The 3.395 mc IF signal from transformer T3 is coupled to the product detector through resistors R200 and R201. The carrier generator oscillator signal (3393.6 kc USB or 3396.4 LSB) is coupled to the product detector through resistors R202 and R203. These two signals are mixed by diodes GD200 through GD203; the resulting audio frequency (the difference frequency) is coupled through the RF filter network, consisting of C201, C202, and choke RFC1, to the first audio preamplifier, transistor Q1.

### First Audio Preamp (Figure 2-23)

The first audio preamplifier, Q1, amplifies the low level audio signal from the balanced modulator to a level that is usable by the second audio preamplifier. A transistor is used here for three reasons: to maintain a very low hum level; to match the low impedance output of the balanced modulator more closely; and to raise the audio voltage to a value more usable by the tube-type second audio preamplifier.

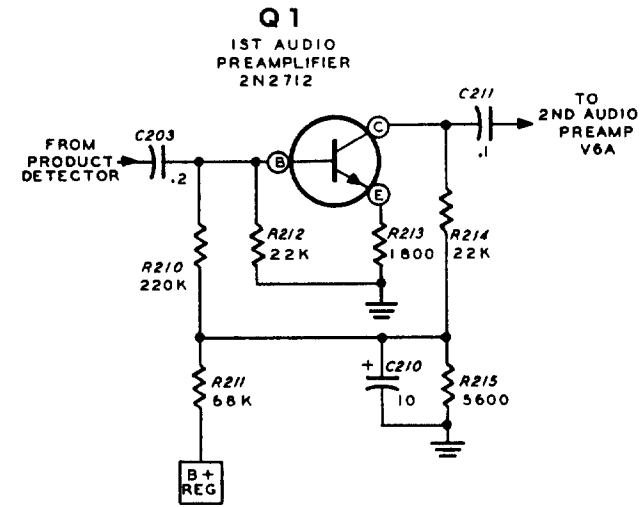

Figure 2-23

### Second Audio Preamp And Audio Output (Figure 2-24)

Further amplification takes place in the second audio preamplifier and the audio output stages to bring the audio signal up to a level sufficient to drive an 8 Ω speaker. The audio output level is controlled by the AF Gain control. The Headphone Level control reduces the normally higher output level (due to the high impedance of most headsets) to a comfortable level at normal AF Gain settings.

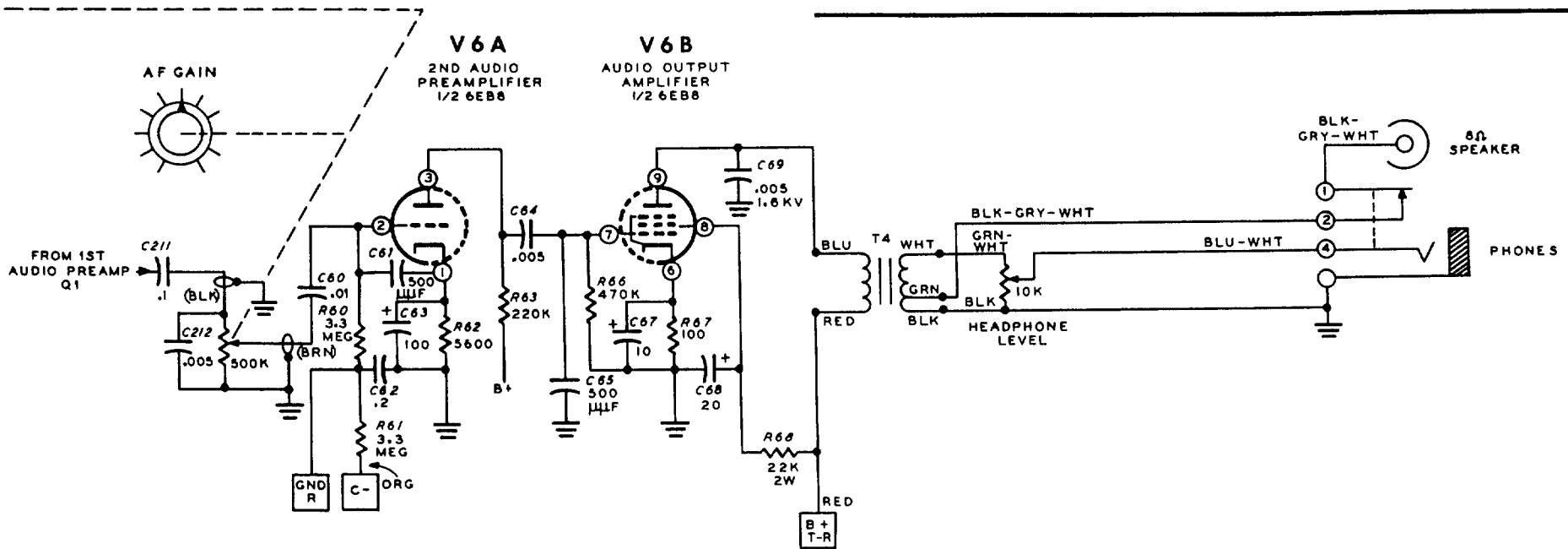

Figure 2-24



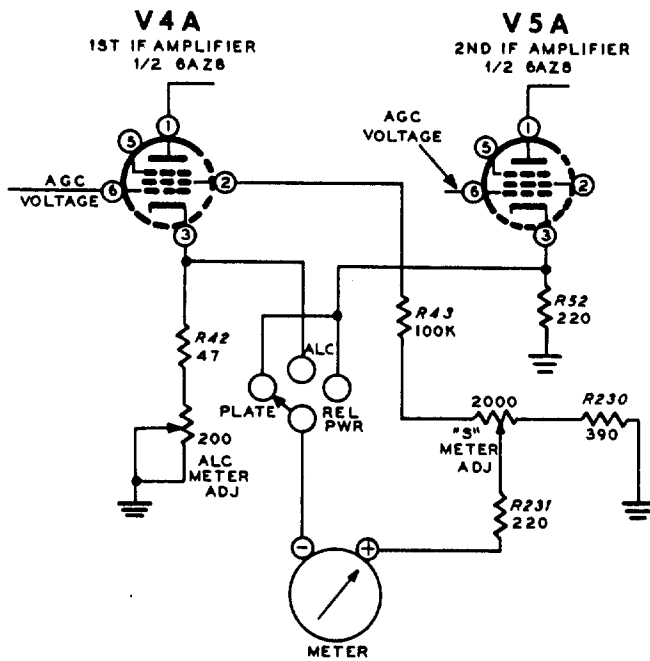

Figure 2-25

## METERING CIRCUITS

### S-Meter (Figure 2-25)

When the Transceiver is in the receive condition, the meter always indicates the relative strength of the received signal. The meter is connected in a bridge-type circuit between the screen grid of first IF amplifier V4A, and the cathode of either V4A or second IF amplifier V5A.

A received signal causes the AGC voltage to be applied to V4A and V5A.

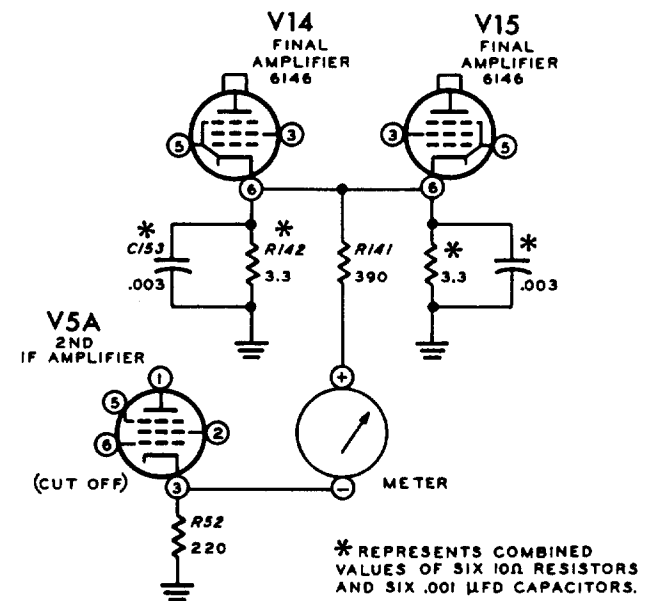

Figure 2-26

This causes the screen voltage to rise and the cathode voltage to decrease because of a reduction in current through the tube. This change in voltage is reflected by an increased reading on the meter.

### Plate Current (Figure 2-26)

Plate current is indicated by measuring the amount of current in the cathode circuit of the final amplifiers. For each 500 ma in the cathode circuit, there will be 1 ma through the meter circuit, which is connected in parallel with the cathode resistors.

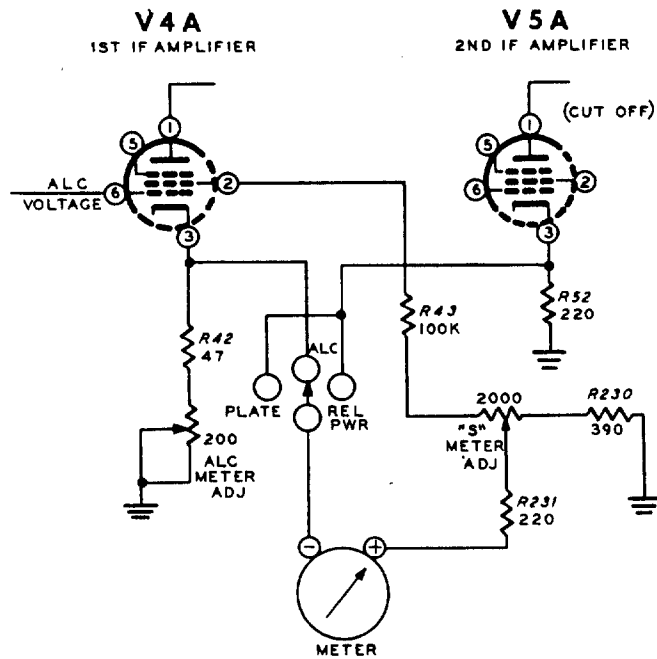

Figure 2-27

ALC (Figure 2-27)

With the Meter switch in the ALC position, the meter is connected in a bridge-type circuit between the screen grid and the cathode of V4A. When the transmitter is in the transmit condition, the gain of V4A is controlled by the ALC voltage much the same as it is controlled by the AGC voltage in receive condition. When ALC voltage increases, the current through V4A is reduced, the screen voltage rises, and this rise is reflected by the meter.

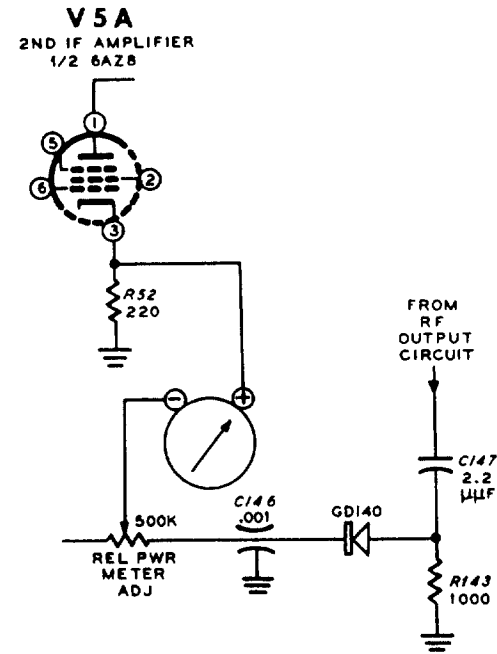
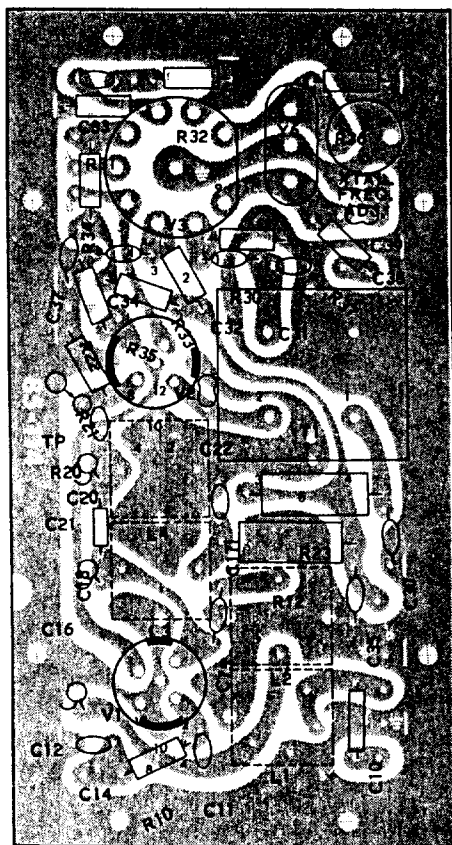

Figure 2-28

Relative Power (Figure 2-28)

Relative power readings are obtained by rectifying a small amount of the RF output with diode GD140. This rectified (DC) voltage is applied across the meter, and is adjusted by the Relative Power Adjust control for full-scale reading when the final RF amplifier is loaded for full output power.



RECEIVER RF  
CIRCUIT BOARD  
#85-114

Figure 3-1

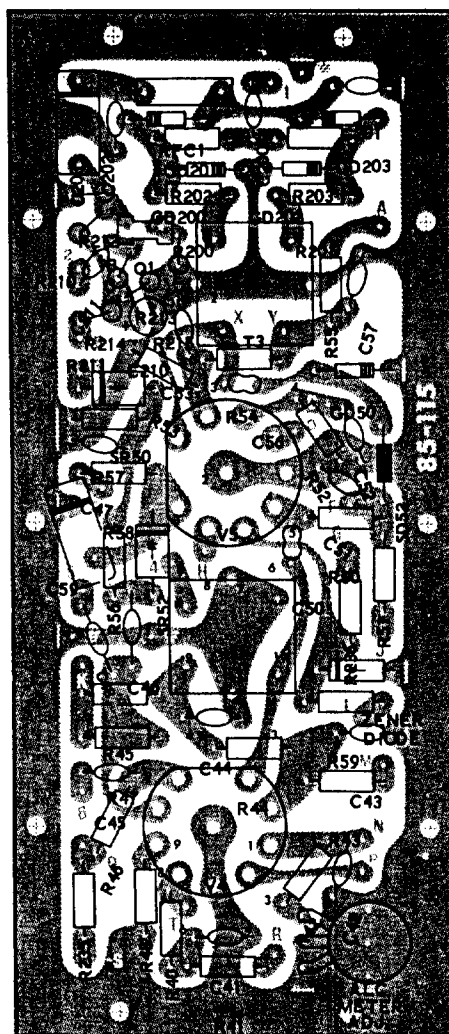

RECEIVER IF  
CIRCUIT BOARD  
#85-115

Figure 3-2

(VIEWED FROM FOIL SIDE)

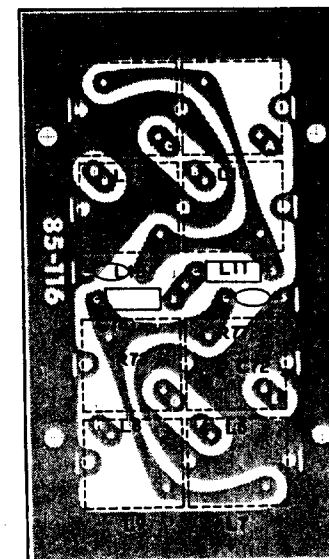

OSCILLATOR COIL  
CIRCUIT BOARD  
#85-116

Figure 3-3



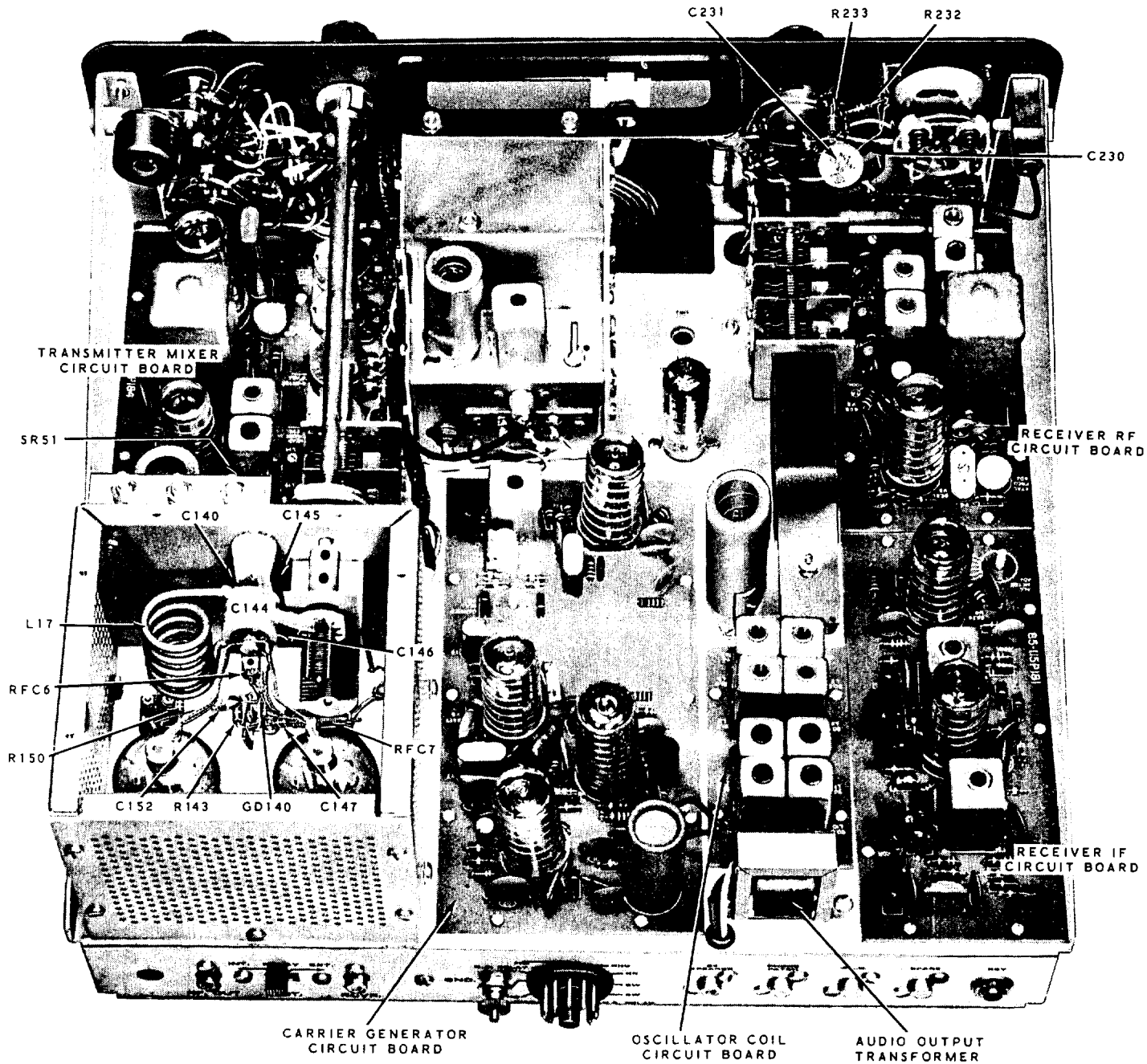

Figure 3-7

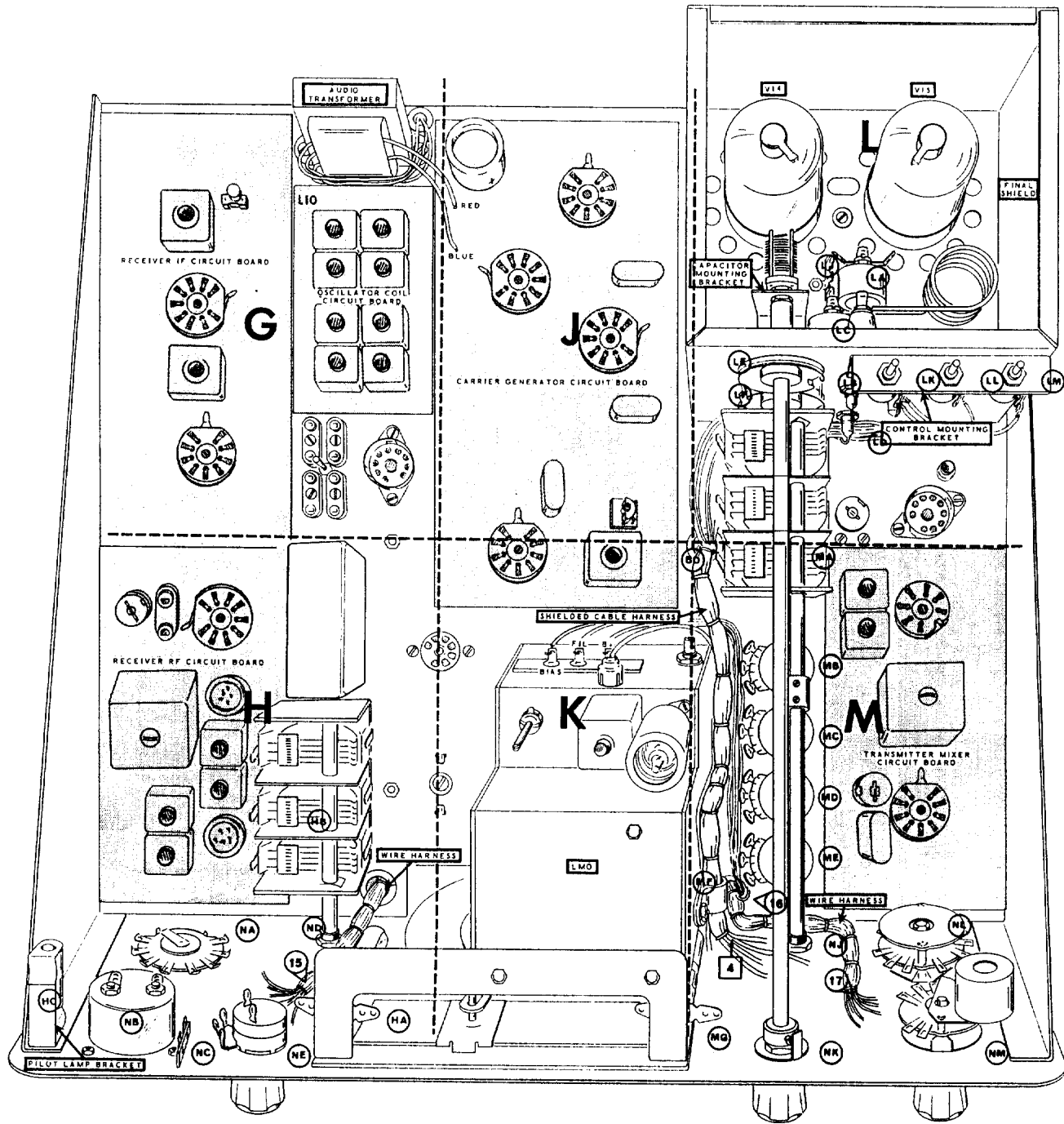

Figure 3-9  
Top

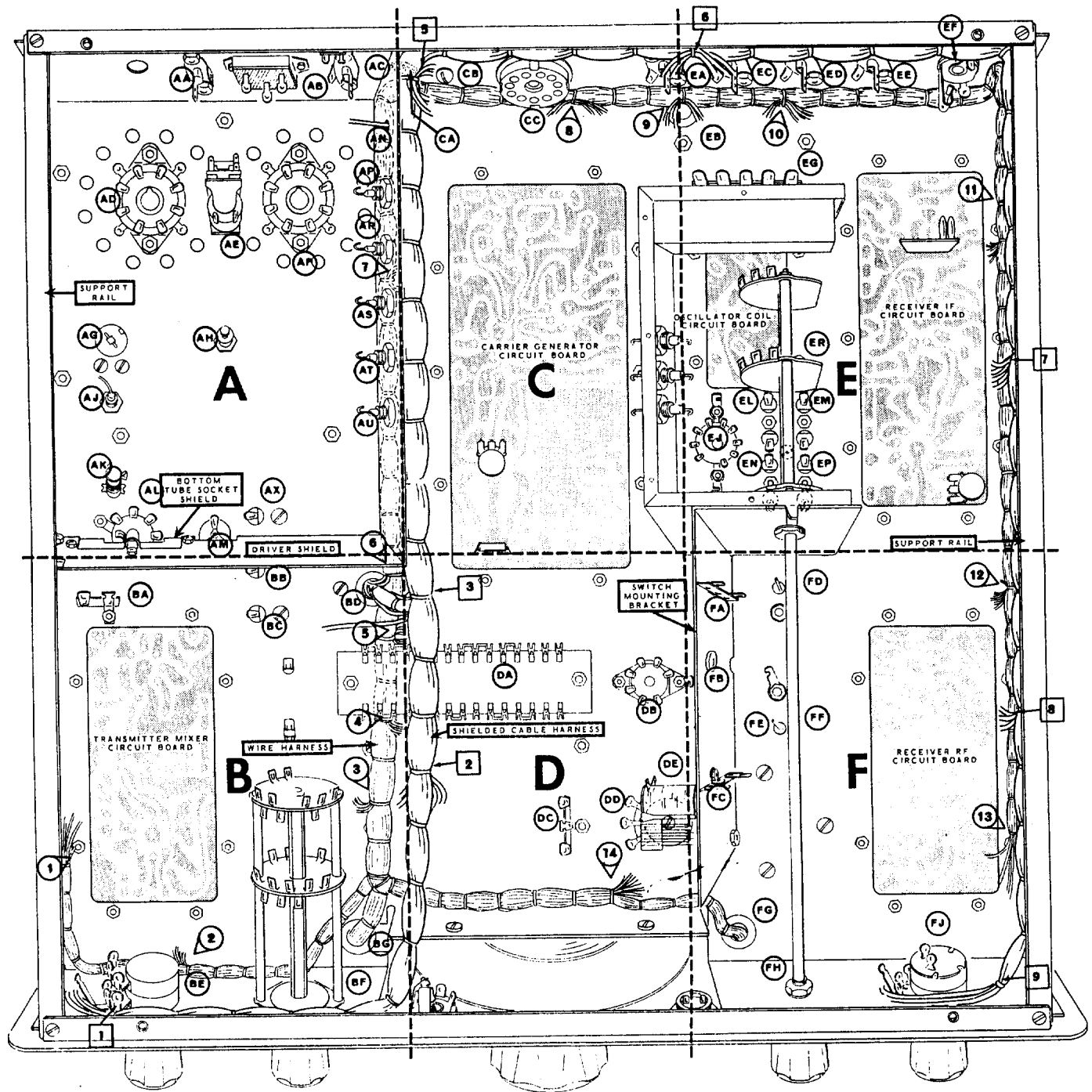

Figure 3-9  
Bottom

\*SEE SCHEMATIC DIAGRAM

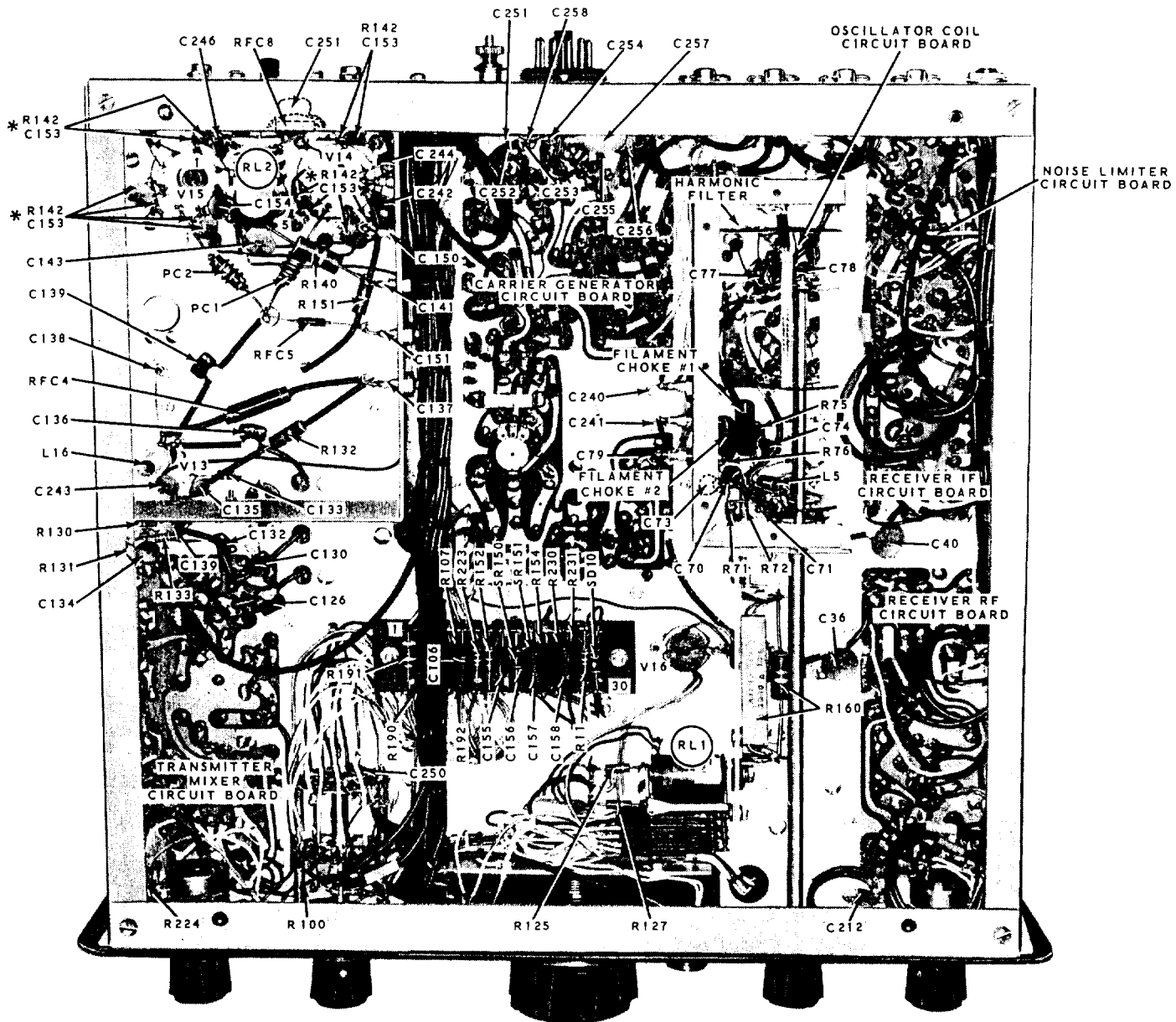

Figure 3-8



## REPLACEMENT PARTS PRICE LIST

### Circuit Board Parts

Circuit Board Parts			PART No.	PRICE Each	DESCRIPTION	PART No.	PRICE Each	DESCRIPTION
<b>RESISTORS</b>								
1/2 Watt								
1-1	.10	47 Ω	Mica (cont'd.)			40-672	.25	.415 μh (red coil form)
1-3	.10	100 Ω	20-97	.15	50 μμf	40-670	.60	.47 μh (grn coil form)
1-45	.10	220 Ω	20-109	.15	62 μμf	40-668	.60	.65 μh (yel coil form)
1-9	.10	1000 Ω	20-102	.15	100 μμf	40-671	.25	.72 μh (wht coil form)
1-93	.10	1800 Ω	20-103	.15	150 μμf	40-667	.60	.73 μh (org coil form)
1-44	.10	2200 Ω	20-107	.40	680 μμf	40-666	.80	8.7 μh (brn coil form-wax covered)
1-46	.10	3900 Ω	Disc					
1-18	.10	5600 Ω	21-33	.10	3.3 μμf	<b>TRANSFORMERS</b>		
1-20	.10	10 KΩ	21-78	.10	5 μμf	52-70	.75	3.395 mc balanced modulator
1-109	.10	12 KΩ	21-61	.10	6.8 μμf	52-88	.75	3.395 mc interstage
1-21	.10	15 KΩ	21-60	.10	18 μμf	52-79	.80	3.395 mc product detector
1-69	.10	18 KΩ	21-13	.10	500 μμf	52-65	5.00	8.4-8.9 mc bandpass coupler
1-22	.10	22 KΩ	21-14	.10	.001 μfd			
1-67	.10	39 KΩ	21-57	.10	.005 μfd 500 V	<b>DIODES</b>		
1-25	.10	47 KΩ	21-72	.20	.005 μfd 1.4 KV	56-26-1	.35	1N191 germanium
1-60	.10	68 KΩ	21-16	.10	.01 μfd	56-28	.60	S187 silicon
1-26	.10	100 KΩ	21-31	.10	.02 μfd	56-25	3.00	1N-4166A zener, 15 V
1-29	.10	220 KΩ	Electrolytic			57-29	.55	Silicon rectifier, 750 ma 100 PIV
1-33	.10	470 KΩ	25-54	.40	10 μfd			
1-100	.15	510 KΩ	25-115	.45	10 μfd	<b>SOCKETS</b>		
1-34	.10	680 KΩ	25-135	.75	20 μfd	434-101	.25	Transistor
1-35	.10	1 megohm	25-117	.60	100 μfd	434-149	.45	Nuvistor tube
1-38	.10	3.3 megohm	Other Capacitors			434-129	.15	7-pin tube
1-40	.10	10 megohm	21-29	.15	4.7 μμf tubular	434-130	.15	9-pin tube
2 Watt			21-41	.10	14 μμf tubular	434-74	.15	Crystal
1-11-2	.20	22 KΩ	26-93	2.85	1.8-13 μμf variable			
1-10-2	.20	47 KΩ	27-47	.20	.1 μfd resin	<b>CRYSTALS</b>		
<b>CAPACITORS</b>			27-34	.25	.2 μfd resin	404-43	5.00	100 kc
Mica			28-2	.10	1 μμf phenolic	404-205	5.00	3393.6 kc
20-52	.15	7.5 μμf	28-1	.10	2.2 μμf phenolic	404-263	3.75	3394.4 kc
20-118	.15	15 μμf	31-36	.85	8-50 μμf trimmer	404-206	5.00	3396.4 kc
20-99	.15	22 μμf						

PART No.	PRICE Each	DESCRIPTION	PART No.	PRICE Each	DESCRIPTION	PART No.	PRICE Each	DESCRIPTION
<b>CIRCUIT BOARDS</b>			<b>1/2 Watt (cont'd.)</b>			<b>Variable</b>		
85-114-1	1.50	Receiver RF	1-26	.10	100 K $\Omega$	26-106	4.75	15 $\mu$ mf 3-section
85-115-2	1.70	Receiver IF	1-29	.10	220 K $\Omega$	26-24	2.20	20 $\mu$ mf
85-116-1	.85	Oscillator coil	1-34	.10	680 K $\Omega$	26-105	2.85	140 $\mu$ mf
85-152-1	2.30	Carrier generator	1-35	.10	1 megohm	<b>Other Capacitors</b>		
85-118-1	1.50	Transmitter mixer	1-36	.10	1.5 megohm	21-29	.15	4.7 $\mu$ mf tubular
85-119-1	.35	Noise limiter	1-86	.10	5.6 megohm	21-114	4.75	150 $\mu$ mf standoff
<b>HARDWARE</b>			<b>1 Watt</b>			21-55	4.30	500 $\mu$ mf standoff
250-133	.05	3-48 x 7/16" screw	1-17-1	.10	100 $\Omega$	27-34	.25	.2 $\mu$ fd resin
252-1	.05	3-48 nut	1-25-1	.10	6800 $\Omega$	28-2	.10	1 $\mu$ mf phenolic
<b>MISCELLANEOUS</b>			1-9-1	.10	10 K $\Omega$	28-1	.10	2.2 $\mu$ mf phenolic
10-147	.75	200 $\Omega$ miniature control	<b>Other Resistors</b>			31-30	1.05	1.5-7 $\mu$ mf trimmer
40-581	.15	620 $\mu$ h RF choke	1-3-2	.20	10 K $\Omega$ 2 watt	31-31	1.05	3-12 $\mu$ mf trimmer
45-39	.20	4.65 $\mu$ h RF choke	1-11-2	.20	22 K $\Omega$ 2 watt	<b>CONTROLS</b>		
84-22	.60	P.E.C. (printed electronic circuit)	1-18-2	.20	33 K $\Omega$ 2 watt	10-52	.40	2000 $\Omega$ tab mount
206-244	.25	Coil shield	3-19-10	.20	2000 $\Omega$ 10 watt	10-57	.35	10 K $\Omega$ tab mount
345-1	.10/ft	Flat braid	<b>CAPACITORS</b>			10-60	.35	500 K $\Omega$ tab mount
417-67	.85	2N2712 transistor	<b>Mica</b>			10-153	.75	1 megohm miniature
490-5	.10	Nut starter	20-52	.15	7.5 $\mu$ mf	10-154	.75	10 megohm miniature
331-6	.15	Solder	20-99	.15	22 $\mu$ mf	12-48	1.50	10 K $\Omega$ -1 megohm dual
	2.00	Manual (See front cover for part number.)	20-100	.15	30 $\mu$ mf	19-60	1.25	10 K $\Omega$ with push-pull switch
<b>Chassis Parts</b>			20-97	.15	50 $\mu$ mf	19-66	1.00	500 K $\Omega$ with push-pull switch
<b>RESISTORS</b>			20-78	.15	56 $\mu$ mf	<b>SWITCHES</b>		
<b>1/2 Watt</b>			20-103	.15	150 $\mu$ mf	60-4	.20	Slide
1-41	.10	10 $\Omega$	<b>Disc</b>			63-386	.95	1-section, 3-position rotary
1-1	.10	47 $\Omega$ spare	21-78	.10	5 $\mu$ mf	63-385	1.50	1-section, 3-position rotary with shield
1-3	.10	100 $\Omega$	21-14	.10	.001 $\mu$ fd	63-383	2.10	1-section, 4-position rotary with snap switch
1-45	.10	220 $\Omega$	21-57	.10	.005 $\mu$ fd	63-384	2.45	2-section, 4-position rotary
1-48	.10	390 $\Omega$	21-72	.20	.005 $\mu$ fd 1.4 KV	63-420	3.00	3-section, 4-position rotary
1-95	.15	560 $\Omega$	21-16	.10	.01 $\mu$ fd	<b>COILS</b>		
1-9	.10	1000 $\Omega$	21-31	.10	.02 $\mu$ fd	40-664	.55	Final plate
1-16	.10	4700 $\Omega$	<b>Feedthrough</b>			40-673	.20	Crystal resonating
1-20	.10	10 K $\Omega$	21-113	.75	360 $\mu$ mf	40-530	.35	Driver plate
1-21	.10	15 K $\Omega$	21-53	.65	.001 $\mu$ fd small			
1-22	.10	22 K $\Omega$	21-59	1.20	.001 $\mu$ fd large			
1-25	.10	47 K $\Omega$						

PART No.	PRICE Each	DESCRIPTION
<b>CHOKES</b>		
45-2	.25	Final plate
45-19	.40	Parasitic
45-39	.20	4.65 $\mu$ h RF
45-51	.25	15 $\mu$ h RF
45-36	.20	7 $\mu$ h
45-35	.15	Filament
<b>TRANSFORMER</b>		
51-123	2.05	Audio output
<b>DIODES</b>		
56-26-1	.35	1N191 germanium
57-29	.55	Silicon rectifier, 750 ma 100 PIV
<b>INSULATORS</b>		
71-5	.45	Small ceramic standoff
71-4	.45	Large ceramic standoff
73-4	.10	5/16" grommet
73-3	.10	1/2" rubber grommet
<b>TERMINAL STRIPS</b>		
431-57	.10	2-lug miniature
431-62	.10	3-lug miniature
431-2	.10	2-lug
431-11	.10	5-lug
431-69	.55	30-lug terminal board
<b>CONNECTORS-JACKS-PLUGS</b>		
432-38	1.10	Male connector
432-39	1.10	Female connector
436-20	.45	2-lug phone jack
436-21	.95	4-lug phone jack
438-4	.10	Phono plug
438-29	.40	11-pin plug

PART No.	PRICE Each	DESCRIPTION
<b>SOCKETS</b>		
434-34	.15	7-pin miniature tube
434-36	.30	9-pin miniature tube
434-53	.70	8-pin tube
434-118	.40	11-pin
434-42	.10	Phono
434-74	.15	Crystal
434-85	.20	Pilot lamp with lead
434-44	.15	Pilot lamp
<b>TUBE SHIELDS-HEAT SINK</b>		
206-77	.15	1-3/4" long 3/4" diameter tube shield
206-68	.10	1-3/4" long 11/16" diameter tube shield
206-206	.15	2" long tube shield
206-3	.20	1-15/16" long tube shield
206-54	.30	2-3/8" long tube shield
206-86	.10	Pilot lamp shield
215-8	.45	Nuvistor heat sink
<b>TUBES-NUVISTORS-PILOT LAMPS</b>		
411-59	1.35	OA2 tube
411-211	2.75	6AZ8 tube
411-218	3.00	6AZ8 tube (painted tip)
411-67	1.05	6CB6 tube
411-182	2.30	6DS4 Nuvistor
411-124	1.50	6EA8 tube
411-161	2.20	6EB8 tube
411-24	1.45	12AT7 tube
411-69	1.55	12BY7 tube
411-75	4.35	6146 tube
412-20	.20	#47 pilot lamp
412-17	.10	#53 pilot lamp
<b>CRYSTALS-CRYSTAL FILTER</b>		
404-264	3.75	41,605 mc crystal
404-265	4.05	42,105 mc crystal

PART No.	PRICE Each	DESCRIPTION
<b>Crystals-Crystal Filter (cont'd.)</b>		
404-266	4.05	42,605 mc crystal
404-267	4.05	43,105 mc crystal
404-283	37.00	3395 kc crystal filter (2.1 kc bandpass)
<b>SHAFTS-BUSHINGS-SHAFT COUPLINGS</b>		
453-36	.15	3-7/8" long shaft
453-108	.60	8-1/4" long tubular shaft
453-125	.25	9-3/8" long shaft
455-11	.10	Split bushing
455-32	.20	Dial bushing
455-38	.10	Threaded bushing
456-7	.25	Shaft coupling
<b>KNOBS</b>		
462-175	.15	7/16" diameter aluminum
462-191	.70	1-1/8" diameter
462-193	1.05	2-1/2" diameter
462-195	.50	Lever
<b>DIAL PARTS</b>		
258-1	.05	Dial cord spring
349-1	.05/ft	Dial cord
446-40	.70	Dial escutcheon
100-19	.20	Dial pulley with 1/4" hole
100-458	.25	Dial pulley with 9/32" hole
<b>#100-450 Packaged Dial Drive Assembly, 6.00</b>		
<b>Consisting Of The Following:</b>		
204-553	.55	Dial mounting bracket
100-443	1.00	Dial pointer assembly
464-30-1	.25	Plastic dial window
100-447	.50	Dial pointer drive arm
250-63	.05	3-48 x 1/8" screw
266-74	.10	Nylon spiral follower
100-445	.45	Zero set drive pulley (small)
100-449	2.50	Circular dial
100-444	1.65	Dial drive pulley (large)
455-42	.90	Drive shaft bushing assembly

PART No.	PRICE Each	DESCRIPTION	PART No.	PRICE Each	DESCRIPTION	PART No.	PRICE Each	DESCRIPTION
<b>CABLE HARNESSSES-WIRE-SLEEVING</b>			<b>HARDWARE</b>			<b>1/4" Control Hardware</b>		
134-134	8.00	Wire harness	<b>#3 Hardware</b>			252-39	.05	1/4-32 nut
134-119	7.90	Coaxial cable harness	250-49	.05	3-48 x 1/4" screw	254-14	.05	1/4" lockwasher
340-2	.05/ft	Bare wire	250-172	.05	3-48 x 3/8" screw	259-12	.05	1/4" solder lug
343-7	.05/ft	Coaxial cable	250-251	.20	48 x 3/8" flat head screw	<b>3/8" Control Hardware</b>		
343-10	.10/ft	Teflon coaxial cable	250-133	.05	3-48 x 7/16" screw	252-7	.05	3/8-32 nut
346-1	.05/ft	Small sleeving	252-1	.05	3-48 nut	253-10	.05	3/8" flat washer
346-2	.05	Large sleeving	254-7	.05	#3 lockwasher	254-5	.05	3/8" lockwasher
<b>METAL PARTS</b>			<b>#4 Hardware</b>			259-10	.05	3/8" solder lug
90-341	20.80	Cabinet	250-156	.10	4-40 x 1/8" setscrew	<b>Other Hardware</b>		
205-479	.45	Final shield rear plate	252-15	.05	4-40 x 3/16" nut	207-19	.10	Cable clamp
204-653	.15	Capacitor mounting bracket	254-9	.05	#4 lockwasher	250-143	.05	6-32 x 1/2" threaded stud
205-478	.35	Final shield top plate	<b>#6 Hardware</b>			251-1	.05	6-32 spade bolt
206-277	.60	Final shield	250-230	.20	6-32 x 3/16" setscrew	253-60	.05	#6 flat washer
204-652-1	.15	Control mounting bracket	250-56	.05	6-32 x 1/4" screw	254-15	.05	5/16" lockwasher
204-9	.10	Angle bracket	250-170	.05	#6 x 1/4" sheet metal screw	255-2	.05	3/16" long spacer
205-531-1	.15	Crystal retaining plate	250-32	.05	6-32 x 3/8" flat head screw	255-50	.05	19/32" long spacer
200-548-1	5.80	Chassis	250-218	.05	6-32 x 3/8" phillips head screw	259-6	.05	Small #6 solder lug
204-412	.15	Pilot lamp mounting bracket	250-89	.05	6-32 x 3/8" screw	259-1	.05	Large #6 solder lug
204-560	.25	Support rail	250-26	.05	6-32 x 5/8" screw	260-39	.05	Anode clip (appearance may vary)
203-414-1	1.90	Front panel	250-13	.05	6-32 x 1" screw	435-1	.10	11-pin socket retaining ring
204-654	.35	Switch mounting bracket	250-40	.05	6-32 x 1-1/2" screw	<b>MISCELLANEOUS</b>		
206-276	.70	Driver shield	252-3	.05	6-32 nut	69-17	5.00	SPDT relay
205-87	.10	Bottom tube socket shield	252-23	.05	6-32 knurled nut	69-21	8.65	4PDT and 3PST relay
206-308	.70	Heterodyne oscillator shield	253-1	.05	#6 fiber flat washer	74-6	.25	Roll tape
206-309	.35	Heterodyne oscillator cover	254-1	.05	#6 lockwasher	100-591	5.00	Harmonic filter
<b>TOOLS</b>			<b>#8 Hardware</b>			110-28	57.00	LMO (linear master oscillator)
205-254	.10	Alignment tool blade	250-260	.05	8-32 x 1/4" oval head screw	255-59	.15	Foot spacer
490-1	.10	Alignment tool	250-93	.05	8-32 x 1/4" setscrew	261-9	.05	Rubber foot
490-23	.10	#4 allen wrench	250-22	.05	8-32 x 7/16" setscrew	266-19	.30	180 degree rotational stop
490-14	.10	#6 allen wrench	250-72	.05	8-32 x 3/4" screw	352-13	.15	Silicone grease pod
490-85	.15	#8 allen wrench	252-4	.05	8-32 nut	390-147	.10	High voltage label
490-19	.30	1/4" open end wrench	252-28	.10	8-32 knurled nut	391-29	.15	SB-110 name plate
			253-45	.05	#8 flat washer	407-101	8.30	Meter
			254-2	.05	#8 lockwasher	440-1	.20	11-pin socket cap

The above prices apply only on purchases from the Heath Company where shipment is to a U.S.A. destination. Add 10% (minimum 25 cents) to the price when ordering from an authorized Service Center or Heathkit Electronic Center to cover local sales tax, postage and handling. Outside the U.S.A. parts and service are available from your local Heathkit source and will reflect additional transportation, taxes, duties and rates of exchange.

# TYPICAL COMPONENT TYPES

This chart is a guide to commonly used types of electronic components. The symbols and related illustrations

should prove helpful in identifying most parts and reading the schematic diagrams.

<p><b>RESISTOR</b></p>	<p><b>CAPACITOR</b></p>	<p><b>TUBE</b></p>
<p><b>POTENTIOMETER (CONTROL)</b></p>	<p><b>ELECTROLYTIC CAPACITOR</b></p>	<p><b>TRANSISTOR</b></p>
<p><b>TRANSFORMER (IRON CORE)</b></p>	<p><b>VARIABLE CAPACITOR</b></p>	<p><b>RECTIFIER (DIODE)</b></p>
<p><b>TRANSFORMER (ADJUSTABLE POWDERED IRON CORE) ARROW INDICATES DIRECTION OF CORE MOVEMENT TO INCREASE INDUCTANCE</b></p>	<p><b>BATTERY</b></p>	<p><b>NEON BULB</b></p>
<p><b>TRANSFORMER (ADJUSTABLE CORE)</b></p>	<p><b>PHONO JACK</b></p>	<p><b>ILLUMINATING BULB</b></p>
<p><b>POWER TRANSFORMER</b></p>	<p><b>PHONE JACK</b></p>	<p><b>METER</b></p>
<p><b>INDUCTOR (COIL)</b></p>	<p><b>RECEPTACLE</b></p>	<p><b>SPST SWITCH (TOGGLE)</b> <b>DPDT</b></p>
<p><b>PIEZOELECTRIC CRYSTAL</b></p>	<p><b>SPEAKER</b></p>	<p><b>SWITCH (ROTARY)</b></p>
<p><b>BINDING POST</b></p>	<p><b>MICROPHONE</b></p>	<p><b>FUSE</b></p>
<p><b>ANTENNA</b></p> <p>GENERAL LOOP</p>	<p><b>EARTH GROUND</b></p> <p><b>CHASSIS GROUND</b></p>	<p><b>CONDUCTORS</b></p> <p>NOT CONNECTED CONNECTED SHIELDED</p>

# HEATH COMPANY

BENTON HARBOR, MICHIGAN

*THE WORLD'S FINEST ELECTRONIC EQUIPMENT IN KIT FORM*

LITHO IN U. S. A

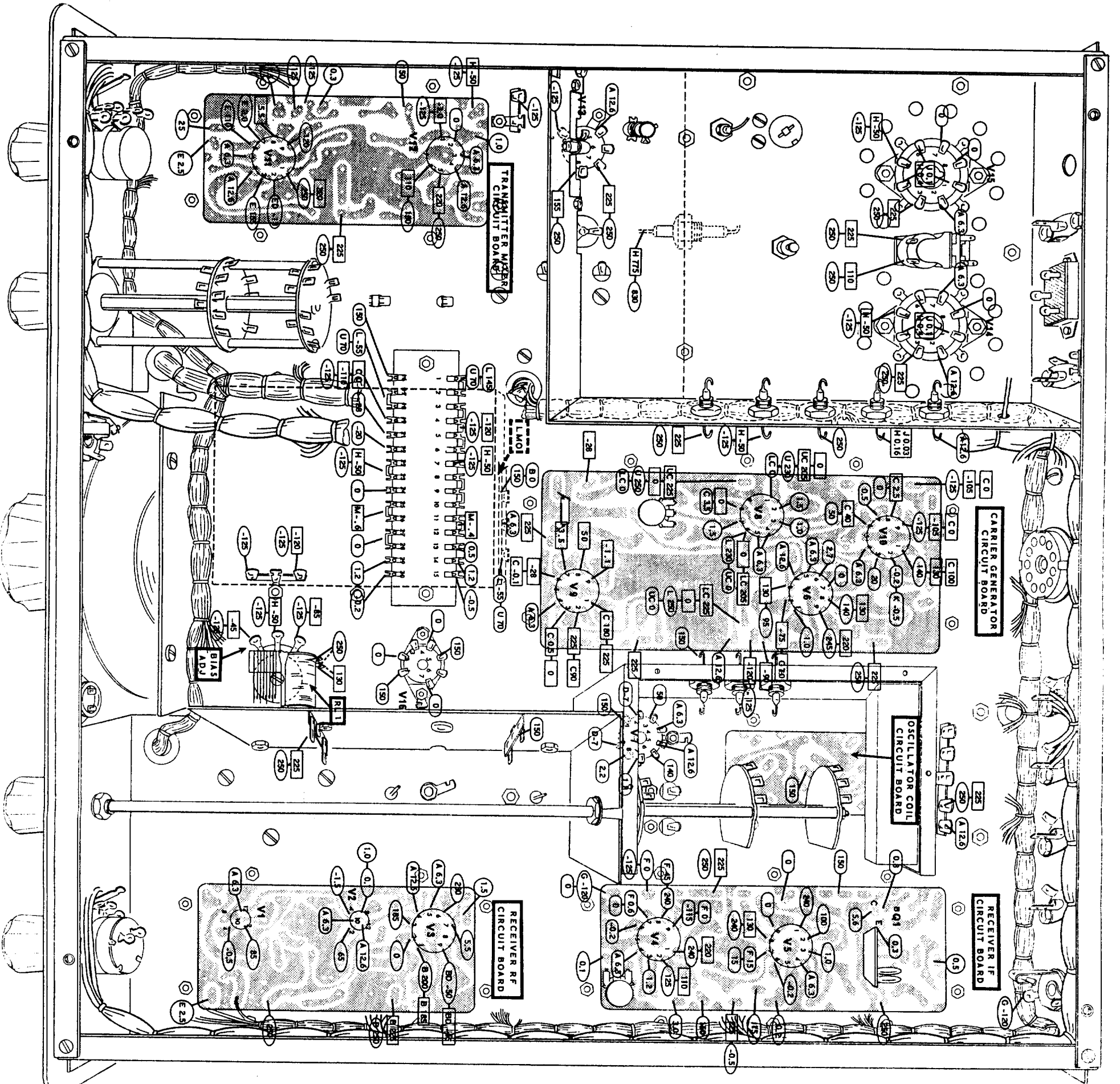

**VOLTAGE CHART**

- A. FILAMENT VOLTAGE. MAY BE AC OR DC DEPENDING ON POWER SUPPLY SOURCE.
- B. WITH OSC. MODE SWITCH IN XTAL POSITION AND WITH CRYSTAL IN SOCKET.
- C. WITH MODE SWITCH IN EITHER USB OR LSB AND TRANSMITTER ACTIVATED BY PTT.
- D. THESE VOLTAGE READINGS ARE DUE TO RF RECTIFICATION AND MAY VARY 50% FROM THE LISTED VOLTAGES.
- E. WITH FUNCTION SWITCH IN CAL. POSITION.
- F. WITH FUNCTION SWITCH IN VOX POSITION.
- G. WITH MODE SWITCH IN CW POSITION.
- H. VOLTAGE WILL VARY, DEPENDING ON BIAS CONTROL SETTING, BUT SHOULD BE AS INDICATED FOR NORMAL TRANSMIT OPERATION.
- I. SMALLER VOLTAGE INDICATION CORRESPONDS TO 50 MA FINAL AMPLIFIER PLATE CURRENT. LARGER VOLTAGE INDICATION CORRESPONDS TO 250 MA FINAL AMPLIFIER PLATE CURRENT.
- K. MODE SWITCH IN CW POSITION.
- L. MODE SWITCH IN LSB POSITION.
- M. THESE VOLTAGE READINGS REQUIRE TWO TONE TEST SIGNAL INPUT AND WILL VARY DEPENDING ON INPUT AUDIO LEVEL.
- U. MODE SWITCH IN USB POSITION.

○ INDICATES VOLTAGE IN RECEIVE OPERATION ONLY. (MODE SWITCH IN EITHER USB OR LSB POSITION).

□ INDICATES VOLTAGE IN TRANSMIT OPERATION ONLY. (MODE SWITCH IN TUNE POSITION).

NOTE: WHEN THE VOLTAGE AT A MEASURING POINT IS INDICATED BY ONLY ONE OF THE TWO SYMBOLS ABOVE, IT SHOULD BE UNDERSTOOD THAT THE VOLTAGE WILL BE ZERO FOR THE OTHER MODE OF OPERATION.

○ INDICATES VOLTAGE IN RECEIVE OR TRANSMIT OPERATION.

○ INDICATES RIAS VALUE OF RF VOLTAGE AND MAY VARY 50% FROM THE LISTED VOLTAGE.

○ ALL VOLTAGE READINGS TAKEN WITH THE "MC" LEVEL CONTROL IN ITS FULLY COUNTERCLOCKWISE POSITION. THE FUNCTION SWITCH IS NORMALLY IN CAL POSITION UNLESS THE LEGEND ABOVE INDICATES OTHERWISE.

○ THE OSC. MODE SWITCH IS NORMALLY IN THE LMO POSITION UNLESS THE LEGEND ABOVE INDICATES OTHERWISE.

○ ALL VOLTAGES ARE MEASURED FROM POINT INDICATED TO GROUND WITH AN 11 MEGOHM INPUT TVM. VOLTAGES MAY VARY 50%.

○ ALL VOLTAGES ARE POSITIVE UNLESS MARKED OTHERWISE.

**FIGURE 1.13**

FIGURE 3-9  
TOP

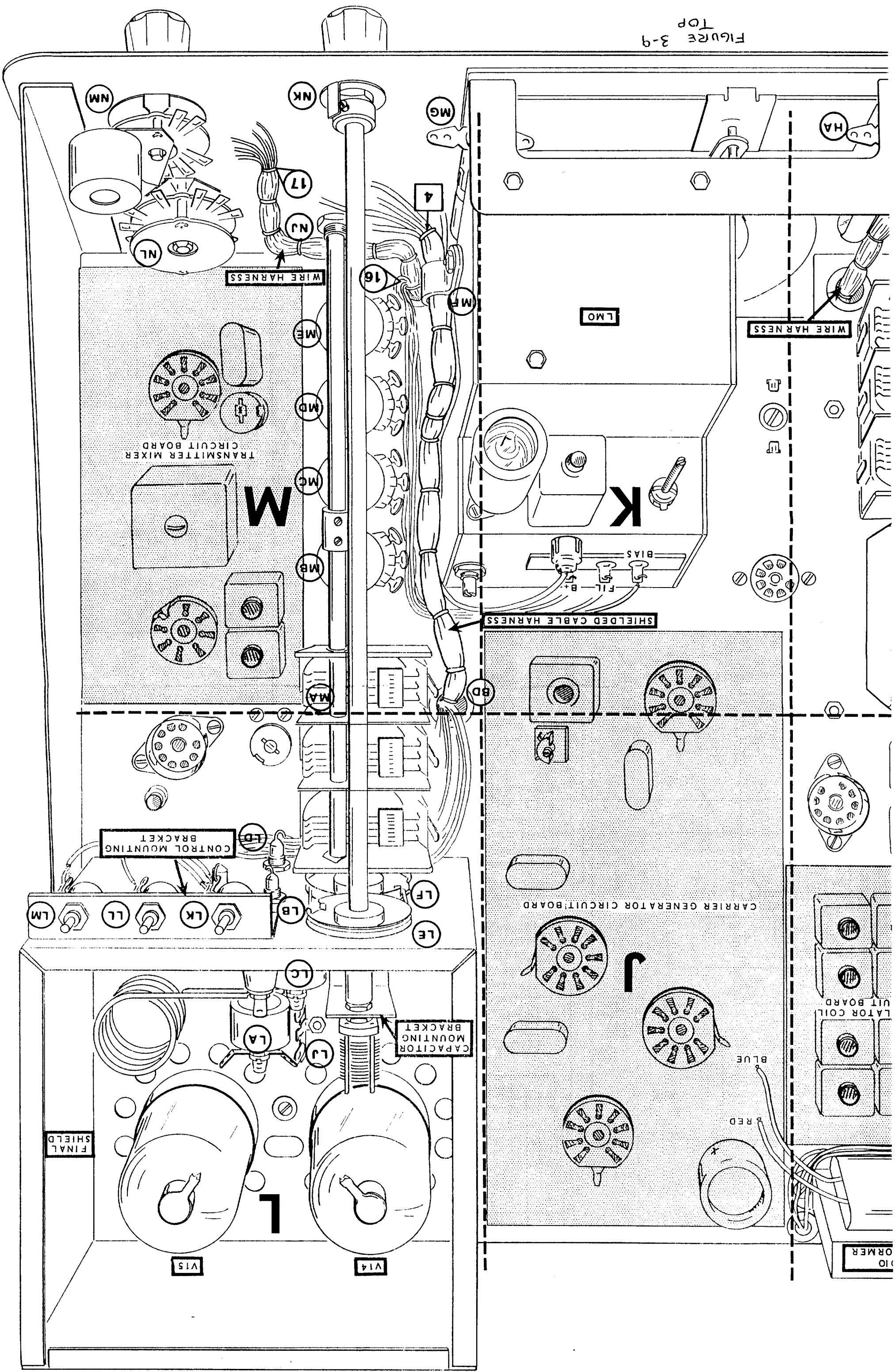



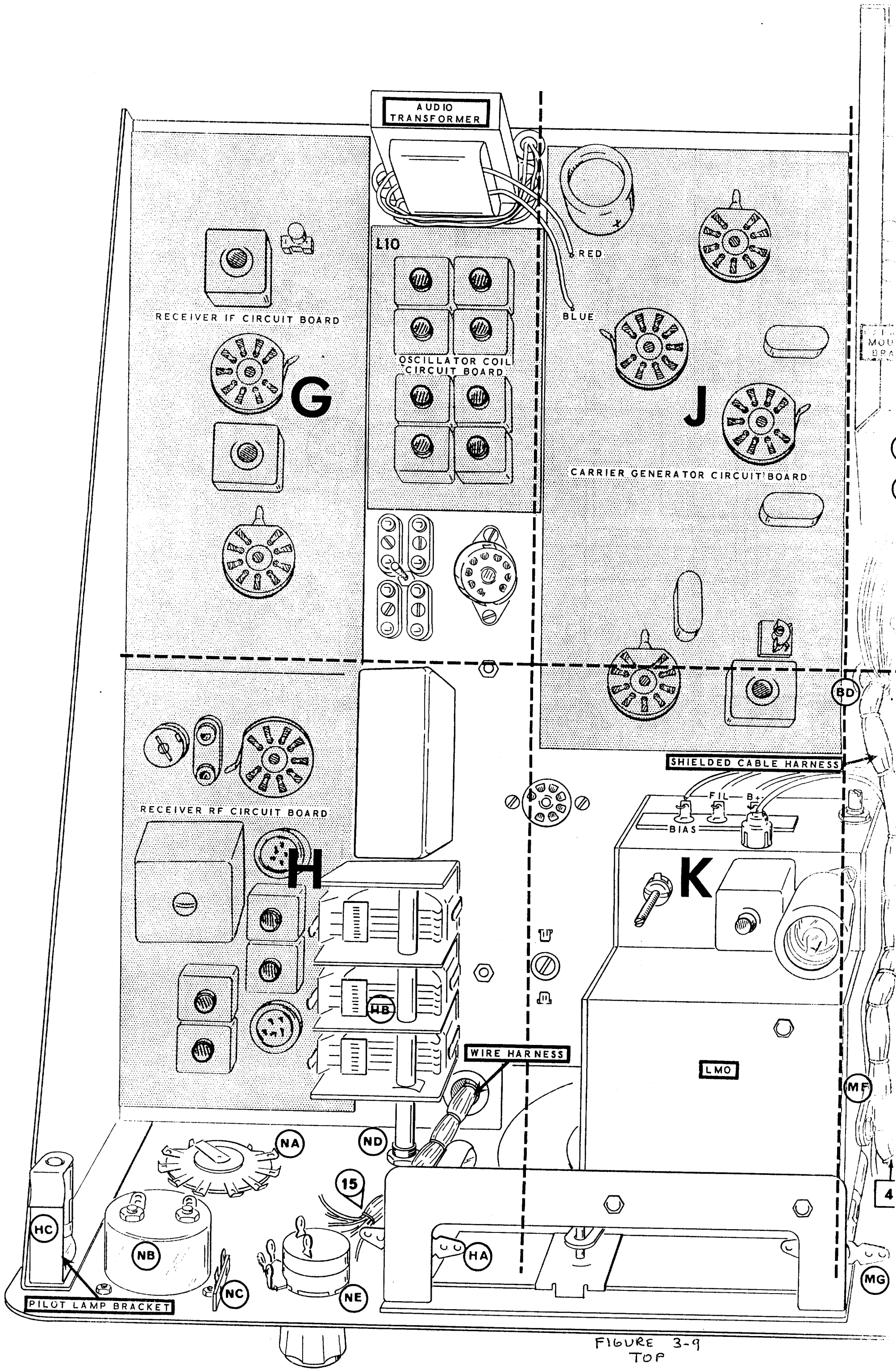
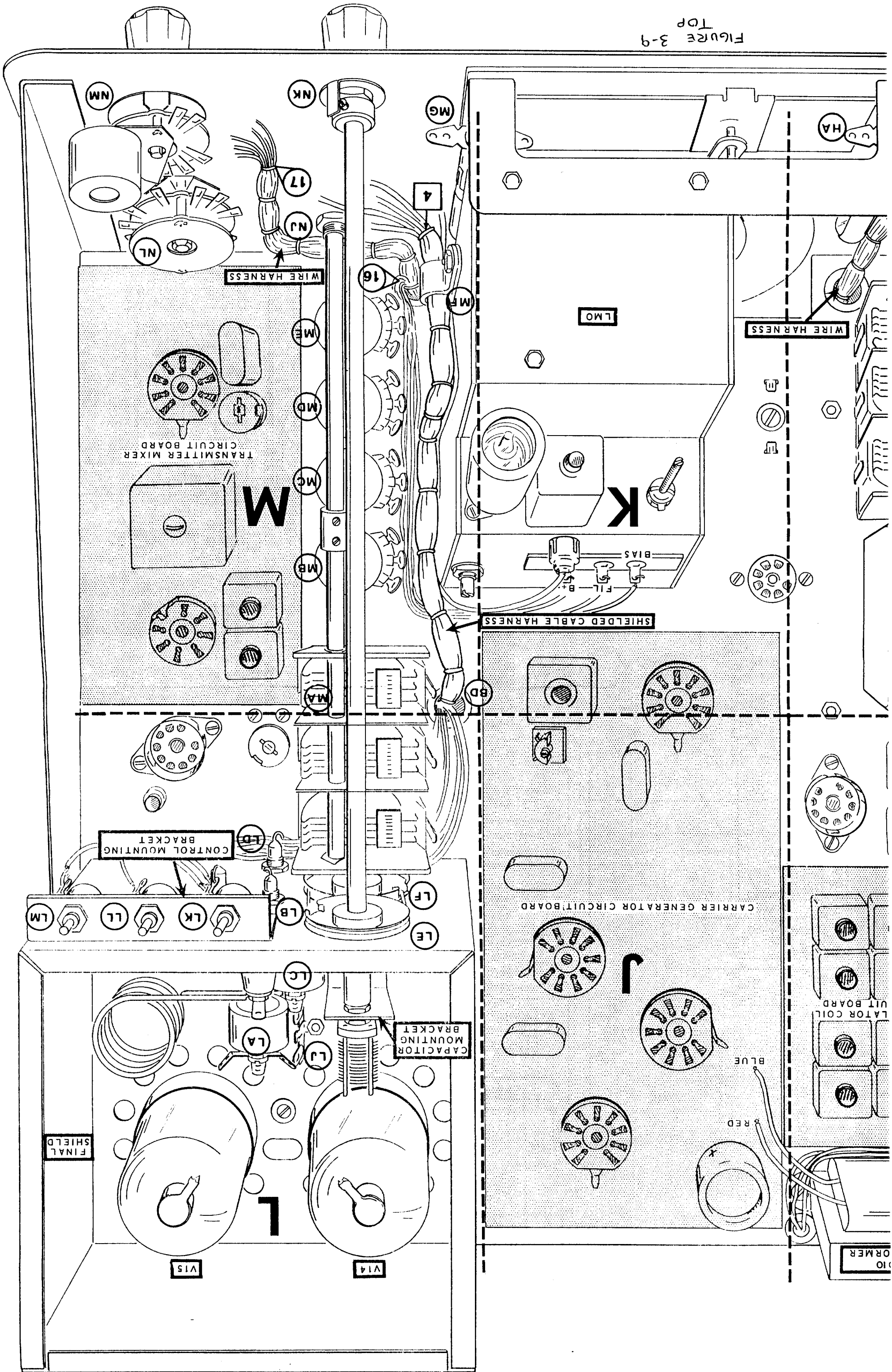

FIGURE 3-9  
TOP

FIGURE 3-9  
TOP



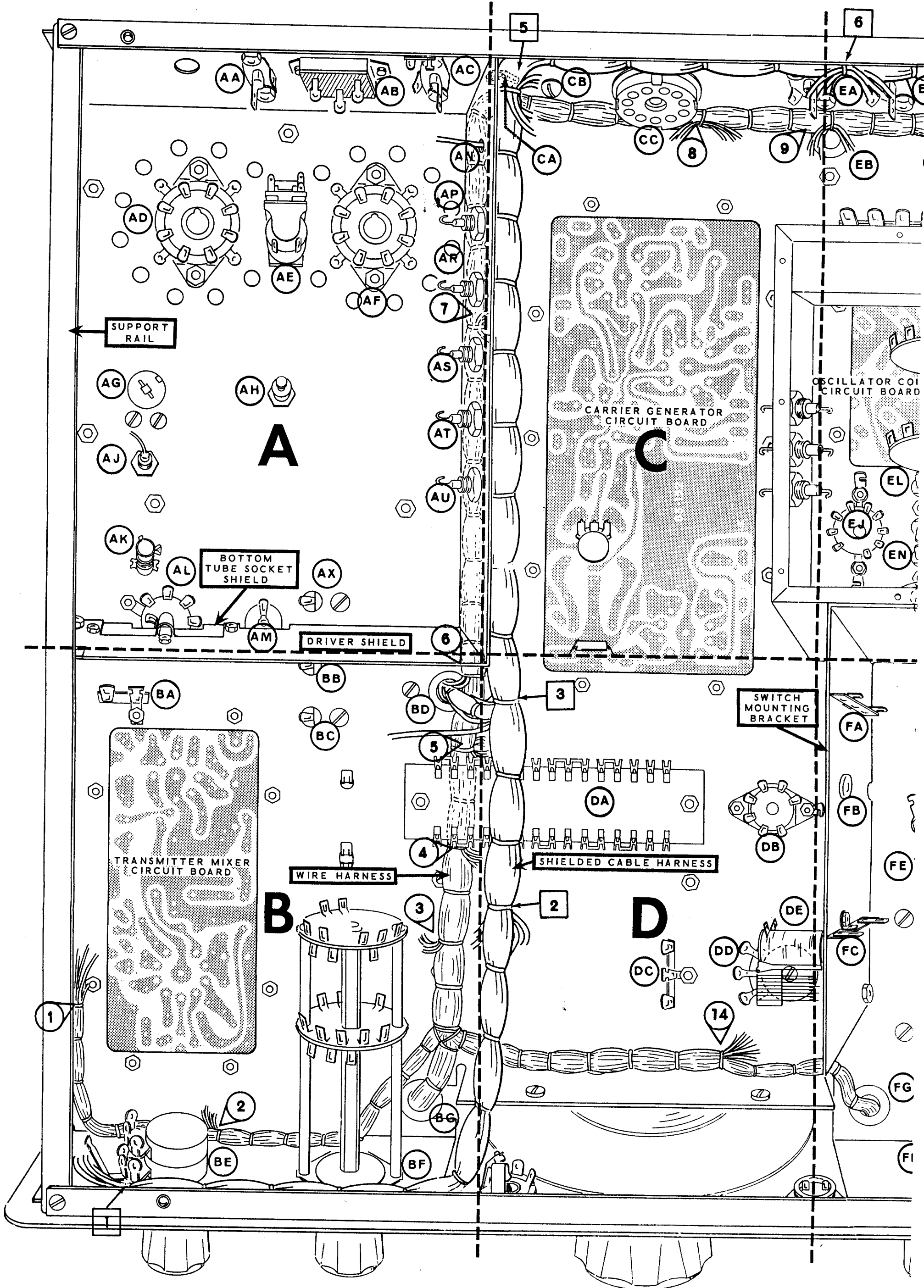
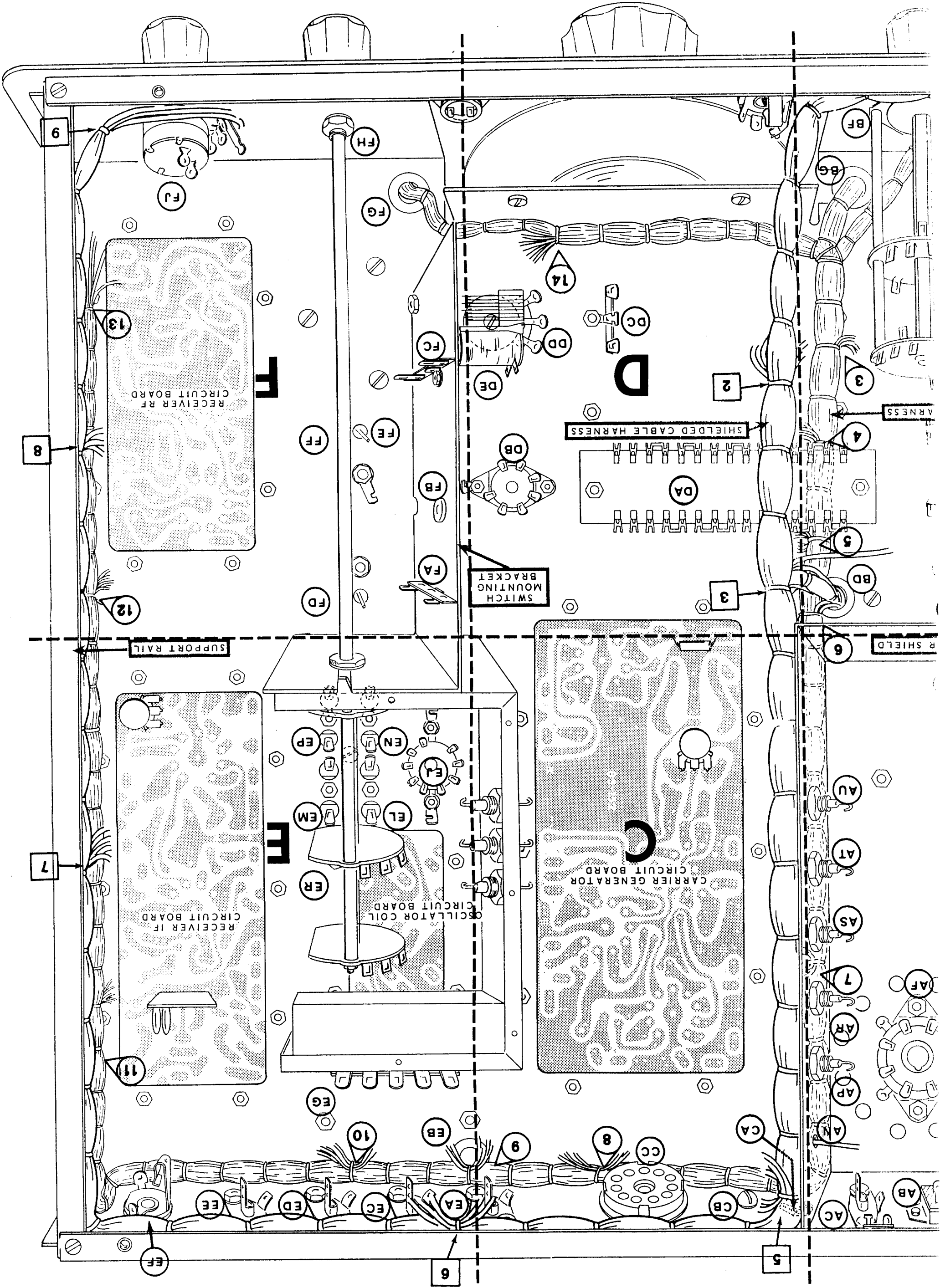
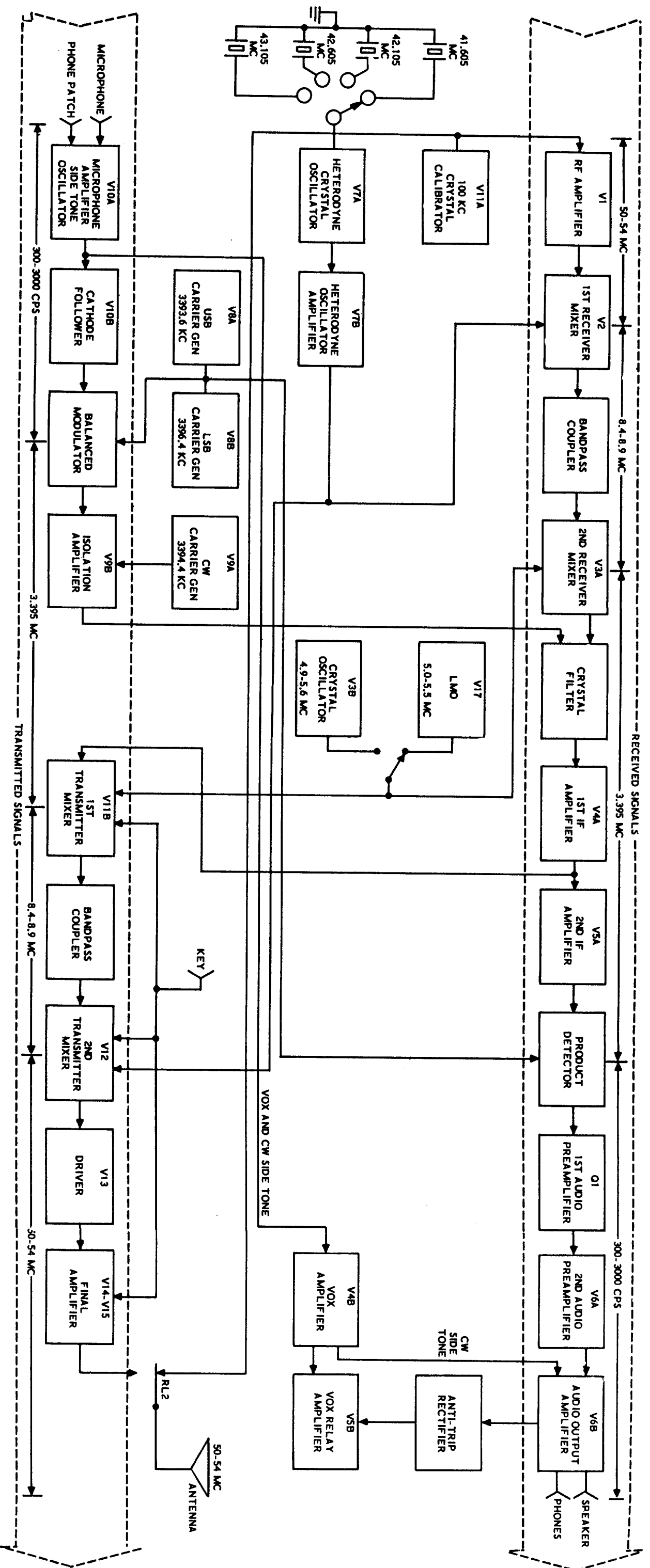

Figure 3-9  
Bottom

Figure 3-9  
Bottom





BLOCK DIAGRAM

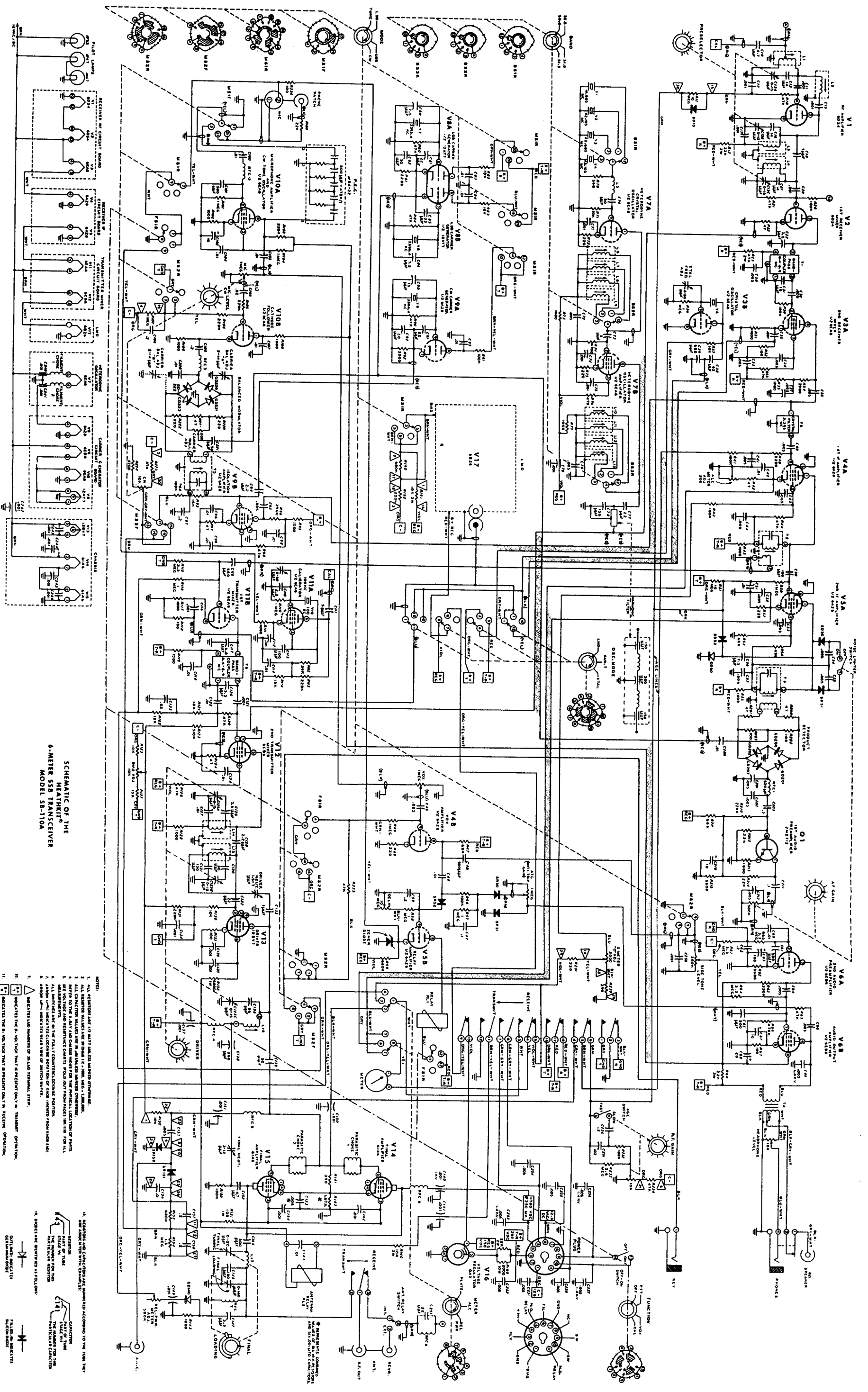

**SCHEMATIC OF THE HEATHKIT® 6-METER 5S8 TRANSCEIVER MODEL S8-10A**

- NOTES:**
1. ALL RESISTOR AND CAPACITOR VALUES ARE SHOWN UNLESS OTHERWISE SPECIFIED.
  2. ALL CAPACITOR VALUES ARE IN MICROFARADS UNLESS OTHERWISE SPECIFIED.
  3. ALL CAPACITOR VALUES ARE IN MICROFARADS UNLESS OTHERWISE SPECIFIED.
  4. REFER TO THE Schematic AND COMPONENT LIST FOR THE PHYSICAL LOCATION OF PARTS.
  5. REFER TO THE Schematic AND COMPONENT LIST FOR THE PHYSICAL LOCATION OF PARTS.
  6. ALL PARTS ARE IN THE "AS SHOWN" POSITION UNLESS OTHERWISE SPECIFIED.
  7. SHOWN IN THE "AS SHOWN" POSITION UNLESS OTHERWISE SPECIFIED.
  8. INDICATES THE NUMBER OF SLIDING CONTACTS.
  9. INDICATES THE NUMBER OF SLIDING CONTACTS.
  10. INDICATES THE NUMBER OF SLIDING CONTACTS.
  11. INDICATES THE NUMBER OF SLIDING CONTACTS.
  12. INDICATES THE NUMBER OF SLIDING CONTACTS.
  13. INDICATES THE NUMBER OF SLIDING CONTACTS.
  14. INDICATES THE NUMBER OF SLIDING CONTACTS.
  15. INDICATES THE NUMBER OF SLIDING CONTACTS.
  16. INDICATES THE NUMBER OF SLIDING CONTACTS.
  17. INDICATES THE NUMBER OF SLIDING CONTACTS.
  18. INDICATES THE NUMBER OF SLIDING CONTACTS.
  19. INDICATES THE NUMBER OF SLIDING CONTACTS.
  20. INDICATES THE NUMBER OF SLIDING CONTACTS.

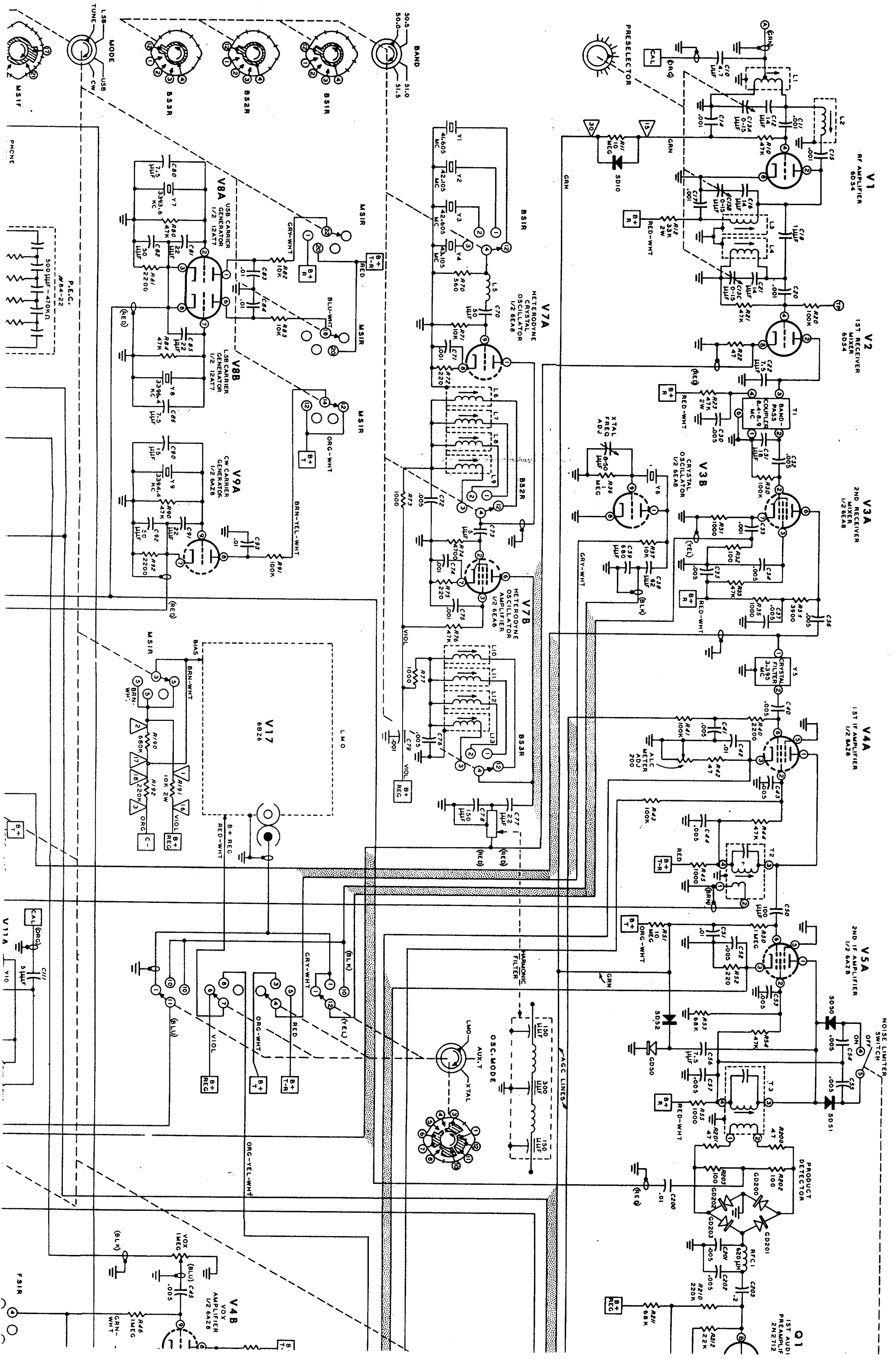

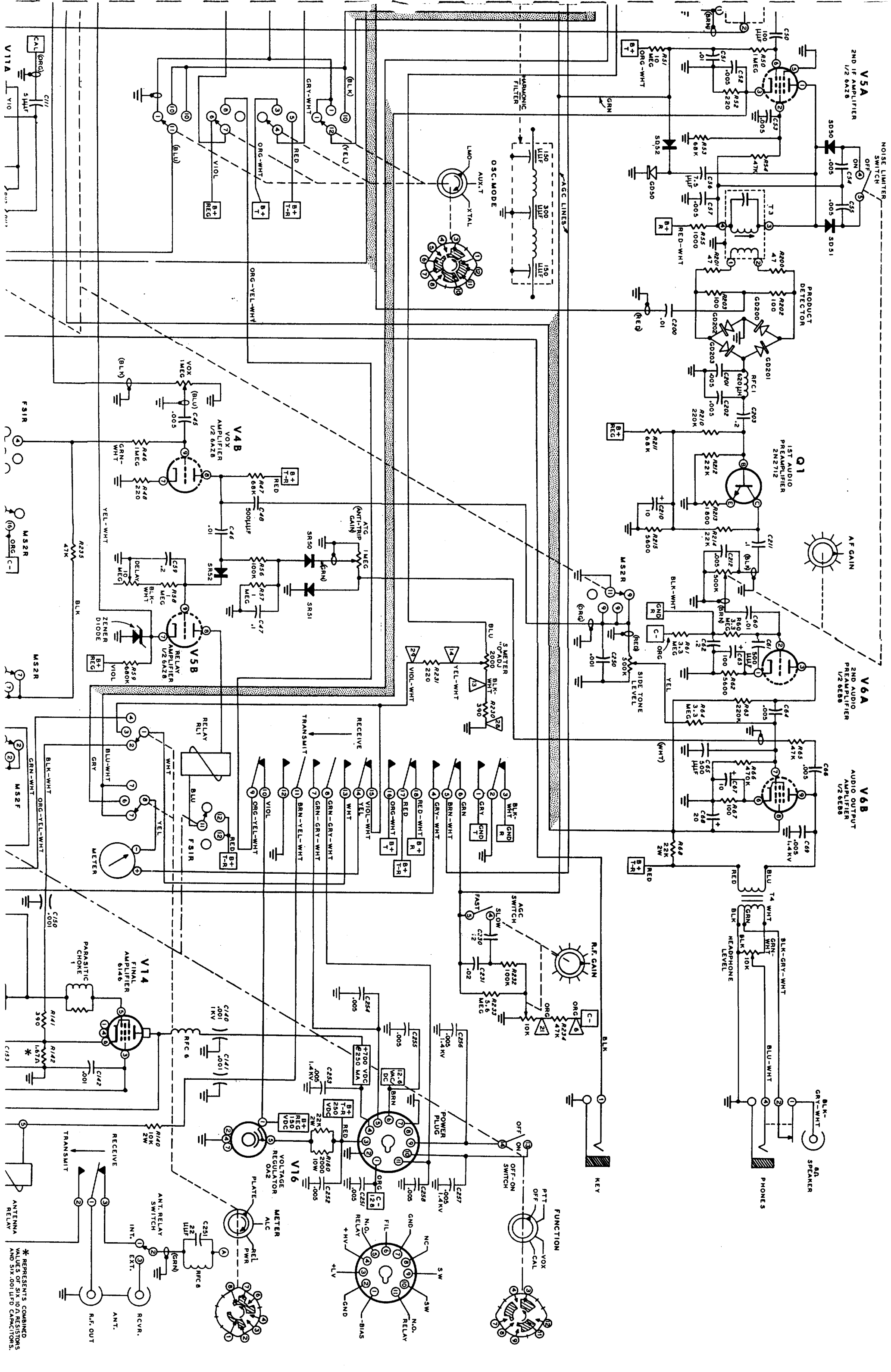

\* REPRESENTS COMBINED VALUES OF SIX 10Ω RESISTORS AND SIX .001μF CAPACITORS.



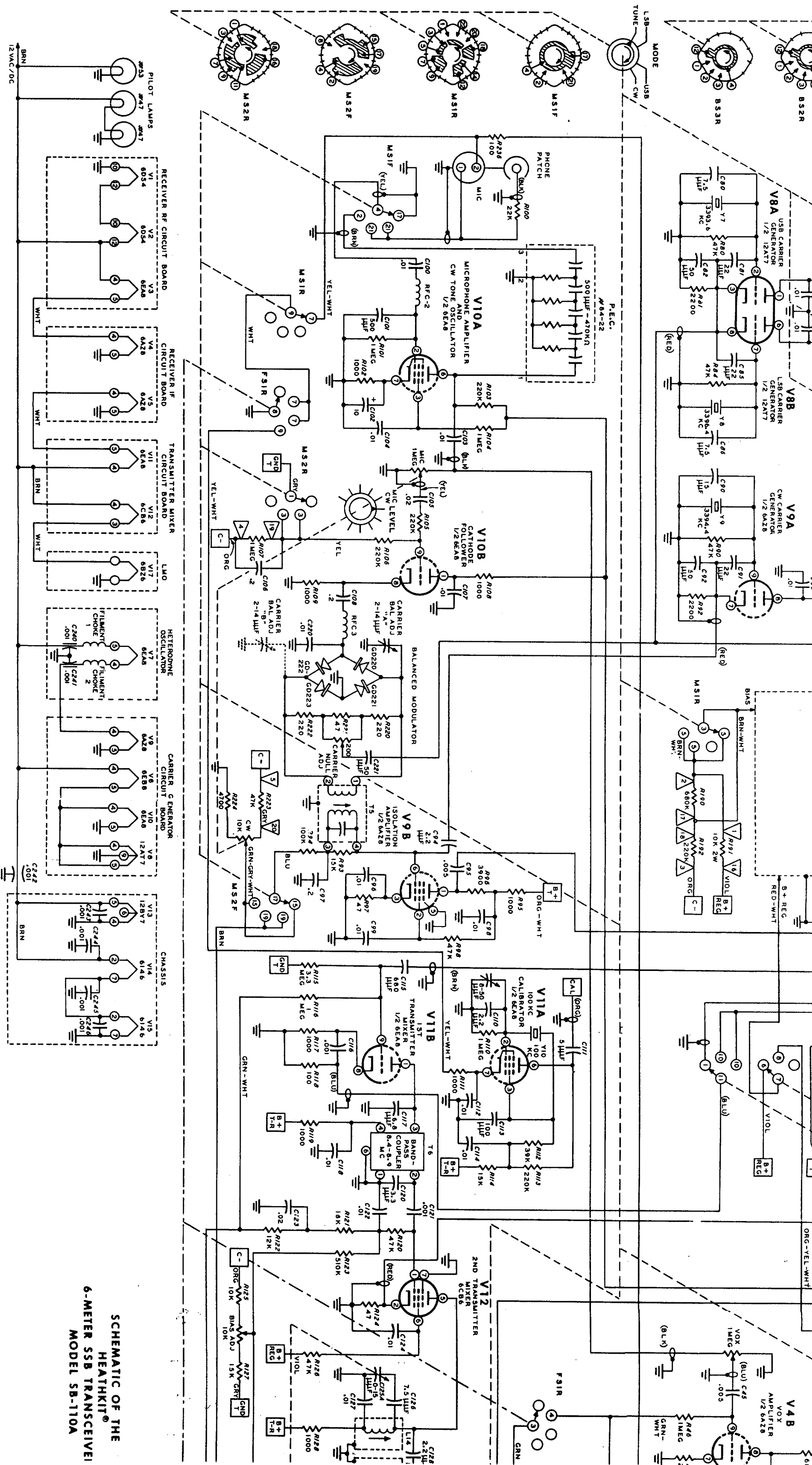

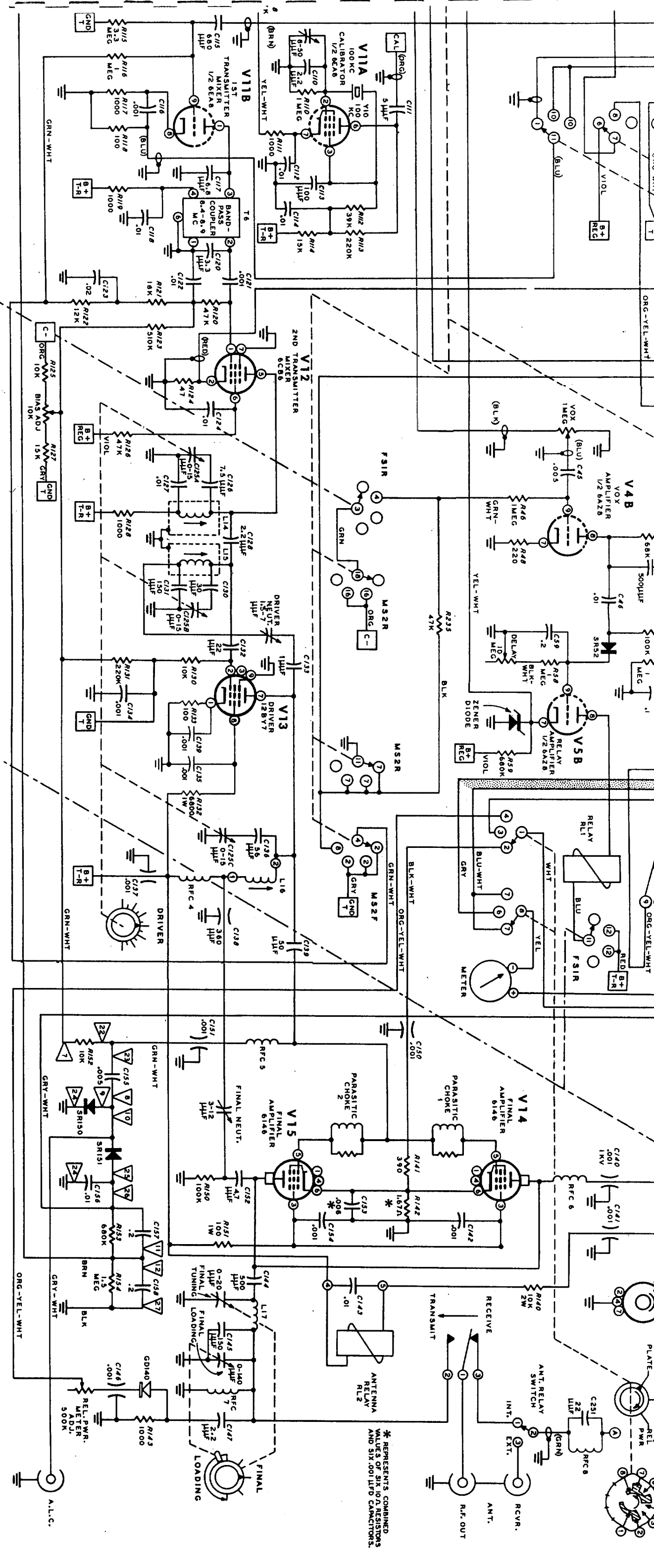

SCHEMATIC OF THE  
HEATHKIT®  
6-METER SSB TRANSCEIVER!  
MODEL SB-110A

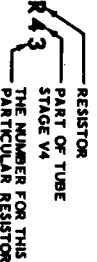

**SCHEMATIC OF THE  
HEATHKIT®  
6-METER SSB TRANSCIEVER  
MODEL SB-110A**

**NOTES:**

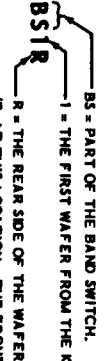
1. ALL RESISTORS ARE 1/2 WATT UNLESS MARKED OTHERWISE.
2. ALL RESISTOR VALUES ARE IN OHMS (K = 1000, MEG = 1,000,000).
3. ALL CAPACITOR VALUES ARE IN μM UNLESS MARKED OTHERWISE.
4. REFER TO THE X-RAY AND CHASSIS VIEWS FOR THE PHYSICAL LOCATION OF PARTS.
5. SEE VOLTAGE AND RESISTANCE CHARTS (FOLD-OUT FROM PAGES 109-110) FOR ALL MEASUREMENTS.
6. ALL SWITCHES ARE IN THE FULLY COUNTERCLOCKWISE POSITION.
7. ARROW (↷) INDICATES CLOCKWISE ROTATION OF KNOB (VIEWED FROM KNOB END).
8. ARROW (↶) INDICATES REAR VIEW OF SWITCH WAFER.
9. ▽ INDICATES LUG NUMBERS OF 30-LUG TERMINAL STRIP.
10. B+ INDICATES THE B+ VOLTAGE THAT IS PRESENT ONLY IN TRANSMIT OPERATION.
11. B+ INDICATES THE B+ VOLTAGE THAT IS PRESENT ONLY IN RECEIVE OPERATION.
12. B+ INDICATES THE B+ VOLTAGE THAT IS PRESENT DURING BOTH TRANSMIT AND RECEIVE OPERATION.
13. GND T INDICATES GROUND WHEN IN TRANSMIT OPERATION.
14. GND R INDICATES GROUND WHEN IN RECEIVE OPERATION.
15. B+ REG INDICATES REGULATED B+.
16. ----- INDICATES ALTERNATE CONNECTION (SEE ALIGNMENT).
17. ( ) INDICATES COLOR CODE OF COAXIAL CABLE.
18. RESISTORS AND CAPACITORS ARE NUMBERED ACCORDING TO THE TUBE THEY ARE ASSOCIATED WITH. EXAMPLES:  

  
RESISTOR PART OF TUBE STAGE V1  
CAPACITOR PART OF TUBE STAGE V1  
C1/1 THE NUMBER FOR THIS PARTICULAR CAPACITOR
19. DIODES ARE IDENTIFIED AS FOLLOWS:  
 OUTLINED INDICATES GERMANIUM DIODE  
 FILLED-IN INDICATES SILICON DIODE
20. ROTARY SWITCHES HAVING MORE THAN ONE WAFER ARE IDENTIFIED AS FOLLOWS:  

  
BS1R BS = PART OF THE BAND SWITCH,  
1 = THE FIRST WAFER FROM THE KNOB END OF THE SWITCH.  
R = THE REAR SIDE OF THE WAFER.  
(F AT THIS LOCATION = THE FRONT SIDE OF THE WAFER.)

\* REPRESENTS COMBINED VALUES OF RESISTORS AND SIX .001 μFD CAPACITORS.